



KAISA HERVONEN

Familial Occurrence of Dermatitis
Herpetiformis and Associated
Conditions



ACADEMIC DISSERTATION

To be presented, with the permission of
the Faculty of Medicine of the University of Tampere,
for public discussion in the auditorium of Finn-Medi 5,
Biokatu 12, Tampere, on September 3rd, 2004, at 12 o'clock.

Acta Universitatis Tampereensis 1026

ACADEMIC DISSERTATION

University of Tampere, Medical School

Tampere University Hospital, Department of Dermatology and Venereology

National Graduate School of Clinical Investigation

Finland

Supervised by

Professor Timo Reunala

University of Tampere

Docent Pekka Collin

University of Tampere

Reviewed by

Professor Ilkka Harvima

University of Kuopio

Docent Risto Julkunen

University of Kuopio

Distribution



University of Tampere

Bookshop TAJU

P.O. Box 617

33014 University of Tampere

Finland

Tel. +358 3 215 6055

Fax +358 3 215 7685

taju@uta.fi

<http://granum.uta.fi>

Cover design by

Juha Siro

Printed dissertation

Acta Universitatis Tamperensis 1026

ISBN 951-44-6049-9

ISSN 1455-1616

Electronic dissertation

Acta Electronica Universitatis Tamperensis 371

ISBN 951-44-6050-2

ISSN 1456-954X

<http://acta.uta.fi>

Tampereen Yliopistopaino Oy – Juvenes Print

Tampere 2004

To my family

ABSTRACT

Dermatitis herpetiformis is a lifelong skin disease characterized by an itchy, blistering rash and pathognomonic IgA deposits in the dermis. It has a gluten-sensitive enteropathy similar, though mostly subclinical, to that in coeliac disease. Genetic predisposition and an autoimmune pathomechanism are typical of coeliac disease, the prevalence of which is as high as 1/100.

Coeliac disease has a tendency to run in families, but knowledge about the familial occurrence of dermatitis herpetiformis is scanty. In the first study (I) of this thesis, 281 patients with dermatitis herpetiformis were questioned after a mean follow-up period of 15 years about the occurrence of dermatitis herpetiformis and coeliac disease in their 1265 first-degree relatives. The prevalence of dermatitis herpetiformis was 1.5% and that of coeliac disease 3.9%. The corresponding prevalences in the 1893 first-degree relatives of 380 patients with coeliac disease were 0.8% and 4.7%. The combined incidence of the two diseases among both groups of relatives was 3/1000/year. In several multiple-case families, dermatitis herpetiformis and coeliac disease occurred in a mixed pattern.

The second study (II) consisted of six monozygous twins of whom the index twin had dermatitis herpetiformis. The other twin had dermatitis herpetiformis in three cases, coeliac disease in two cases and the remaining pair was discordant. The casewise concordance rate was thus 0.91.

Coeliac disease and dermatitis herpetiformis are known for various autoimmune disease associations and a risk of lymphoma. The occurrence of these disorders in the first-degree relatives is, however, not well documented. The third study (III) examined the occurrence of type 1 diabetes in 1104 patients with dermatitis herpetiformis and in 1388 first-degree relatives. Twenty-five (2.3%) of the patients with dermatitis herpetiformis and 20 (1.4%) of the first-degree relatives had type 1 diabetes. Most (88%) of the dermatitis herpetiformis patients with type 1 diabetes could adhere strictly to a gluten-free diet and the rash responded similarly to that in the case controls with isolated dermatitis herpetiformis.

The fourth study (IV) examined the occurrence and type of lymphoma in a series of 1104 patients with dermatitis herpetiformis and in 1825 first-degree relatives. Eleven (1.0%) patients contracted

lymphoma 2-31 years after the diagnosis of dermatitis herpetiformis. Eight were B-cell lymphomas, two enteropathy-associated T-cell lymphomas and one lymphoma remained unclassified in immunohistochemical typing. Three (0.2%) relatives had B-cell lymphoma. The 11 dermatitis herpetiformis patients with lymphoma had adhered to a strict gluten-free diet for a mean of 36 months and the 22 dermatitis herpetiformis case controls without lymphoma for a mean of 102 months, which is a significant ($p=0.041$) difference.

In conclusion, the present results of frequent and mixed presentation of both dermatitis herpetiformis and coeliac disease in the first-degree relatives support the hypothesis that these two disorders are different phenotypes of the same gluten-sensitive disease process. Moreover, monozygous twins with one having dermatitis herpetiformis and the other coeliac disease indicates that different genes are not needed for the development of dermatitis herpetiformis from that of coeliac disease. The present study showed further that associated conditions typical of coeliac disease also occur in dermatitis herpetiformis patients and their relatives. The prevalence of type 1 diabetes was increased in the patients with dermatitis herpetiformis, though less than in coeliac disease, and also in their first-degree relatives. The patients with dermatitis herpetiformis can contract apart from enteropathy-associated T-cell lymphoma also B-cell lymphoma, which can occur in the gut or extraintestinally. The finding that the present patients with lymphoma had adhered to a strict gluten-free diet for significantly fewer months than the dermatitis herpetiformis case controls without lymphoma is in line with the previously reported protective effect of dietary treatment on lymphoma.

CONTENTS

ABSTRACT	5
CONTENTS	7
ABBREVIATIONS	9
LIST OF ORIGINAL PUBLICATIONS.....	11
INTRODUCTION.....	13
REVIEW OF THE LITERATURE.....	15
DERMATITIS HERPETIFORMIS	15
Historical background.....	15
Clinical picture and diagnosis	16
Treatment with gluten-free diet and dapsone	17
COELIAC DISEASE	18
Clinical features	18
Diagnosis of gluten-sensitive enteropathy.....	18
Serological findings.....	20
Gluten-free dietary treatment	21
EPIDEMIOLOGY AND PATHOGENETIC ASPECTS OF COELIAC DISEASE AND DERMATITIS HERPETIFORMIS	22
Epidemiology.....	22
Autoimmune pathogenesis of coeliac disease.....	23
IgA deposits and blister formation in dermatitis herpetiformis.....	25
GENETIC FINDINGS IN COELIAC DISEASE AND DERMATITIS HERPETIFORMIS	26
Family studies	26
Monozygous twins.....	28
HLA and gene studies.....	28
ASSOCIATED DISEASES IN COELIAC DISEASE AND DERMATITIS HERPETIFORMIS.....	29
Type 1 diabetes and other associated disorders.....	29
Lymphoma and other malignancies.....	31
AIMS OF THE PRESENT STUDY	33

PATIENTS AND METHODS	34
PATIENTS AND CONTROLS	34
Dermatitis herpetiformis patients (I, III-IV).....	35
Coeliac disease patients (I).....	35
Monozygous twins (II).....	36
Control patients (III-IV)	36
Ethics	36
METHODS	37
Collection of associated diseases and family data (I, III, IV).....	37
Dermatitis herpetiformis and coeliac disease in first-degree relatives (I).....	38
Type 1 diabetes and lymphoma in first-degree relatives (III, IV)	38
Genetic analyses in monozygous twins (II).....	39
Adherence to a gluten-free diet (III-IV)	39
Typing of lymphomas (IV).....	40
Statistical analyses	40
RESULTS	42
Dermatitis herpetiformis and coeliac disease in first-degree relatives (I).....	42
Concordance of dermatitis herpetiformis and coeliac disease in monozygous twins (II)	43
Type 1 diabetes in dermatitis herpetiformis (III)	45
Lymphoma in dermatitis herpetiformis (IV).....	47
Lymphoma in dermatitis herpetiformis patients and their first-degree relatives	47
Gluten-free diet and lymphoma.....	49
DISCUSSION	50
Dermatitis herpetiformis and coeliac disease in first-degree relatives and monozygous twins	50
Type 1 diabetes in dermatitis herpetiformis.....	52
Lymphoma in dermatitis herpetiformis.....	54
CONCLUSIONS AND FUTURE ASPECTS	56
ACKNOWLEDGEMENTS	59
REFERENCES.....	61
ORIGINAL PUBLICATIONS.....	77

ABBREVIATIONS

CD	coeliac disease
DH	dermatitis herpetiformis
DLBCL	diffuse large B-cell lymphoma
EATL	enteropathy-associated T-cell lymphoma
ELISA	enzyme-linked immunosorbent assay
GFD	gluten-free diet
HLA	human leukocyte antigen
IEL	intraepithelial lymphocyte
IgA	immunoglobulin A
IgG	immunoglobulin G
IL	interleukin
MMP	matrix metalloproteinase
PVA	partial villous atrophy
SIR	standardized incidence ratio
SVA	subtotal villous atrophy
T1D	type 1 diabetes
TcR	T-cell receptor
ThT	helper lymphocyte
TG2	tissue type transglutaminase
TG3	epidermal transglutaminase

LIST OF ORIGINAL PUBLICATIONS

This thesis is based on the following original publications, which are referred to in the text by Roman numerals (I-IV).

- I Hervonen K, Hakanen M, Kaukinen K, Collin P, Reunala T (2002): First-degree relatives are frequently affected in coeliac disease and dermatitis herpetiformis. *Scand J Gastroenterol* 37: 51-55.
- II Hervonen K*, Karell K, Holopainen P, Collin P, Partanen J, Reunala T (2000): Concordance of dermatitis herpetiformis and celiac disease in monozygous twins. *J Invest Dermatol* 115: 990-993.
- III Hervonen K, Viljamaa M, Collin P, Knip M, Reunala T (2004): The occurrence of type 1 diabetes in patients with dermatitis herpetiformis and their first-degree relatives. *Brit J Dermatol* 150: 136-8.
- IV Hervonen K, Vornanen M, Kautiainen H, Collin P, Reunala T (2004): Lymphoma in patients with dermatitis herpetiformis and their first-degree relatives. *Brit J Dermatol*, in press.

*Equal contribution with Karell K. Published earlier in Karell K (2003): Dissecting genetic susceptibility to gluten sensitivity: HLA-linked risk factors in coeliac disease and dermatitis herpetiformis, University of Helsinki, Department of Biosciences, Division of Genetics, Faculty of Science and Finnish Red Cross Blood Transfusion Service.

Original papers are reprinted with the permission of the copyright holders

INTRODUCTION

Dermatitis herpetiformis is a gluten-sensitive, blistering skin disease with the most common predilection sites on the knees, elbows and buttocks. The diagnosis is based on the demonstration of granular IgA deposits in the dermal papillae in the unaffected part of the skin by direct immunofluorescence examination (van der Meer 1969). Only a minority of patients with dermatitis herpetiformis suffer from gastrointestinal symptoms, yet 75% have villous atrophy and the remaining 25% inflammatory changes typical of coeliac disease (Gawkrodger et al. 1984, Savilahti et al. 1992, Vecchi et al. 1992). The rash and the enteropathy both respond to a gluten-free diet, which is the treatment of choice for dermatitis herpetiformis (Fry et al. 1973, Reunala et al. 1977, Garioch et al. 1994). At the beginning of treatment patients having an active rash require, in addition to a gluten-free diet, dapsone to control the rash (Leonard & Fry 1991).

Coeliac disease is a life-long gluten-sensitive disease characterized by small-intestinal mucosal findings of villous atrophy, crypt hyperplasia and an increased number of intraepithelial lymphocytes (IELs) (Mäki & Collin 1997). Both coeliac disease and dermatitis herpetiformis are strongly associated with certain HLA alleles on chromosome 6. About 90% of patients with coeliac disease and dermatitis herpetiformis have the HLA DR3-DQ2 haplotype, and most of the remaining the HLA DR4-DQ8 haplotype (Sollid et al. 1989, Spurkland et al. 1997). The most important environmental factor in the pathogenesis of both these disorders is wheat gluten and related prolamins in barley and rye. The reason why only some patients with gluten-sensitive enteropathy develop dermatitis herpetiformis and about one quarter of dermatitis herpetiformis patients present with normal villous architecture is at present not known.

Coeliac disease has a well-known tendency to run in families (Auricchio et al. 1988, Korponay-Szabo et al. 1998). It is also known that patients with coeliac disease carry an increased risk of contracting autoimmune diseases, like type 1 diabetes (Cooper et al. 1978, Collin et al. 1994). Of the complications of coeliac disease, the most severe is the development of malignancy, especially lymphoma. The most established lymphoma in coeliac disease is enteropathy-associated T-cell lymphoma (EATL) (Isaacson et al. 1985). A gluten-free diet has been reported to give protection against the development of lymphoma (Holmes et al. 1989). In patients with dermatitis herpetiformis,

evidence of familial occurrence, associated autoimmune diseases and type of lymphoma has been scanty and in their first-degree relatives non-existent.

REVIEW OF THE LITERATURE

DERMATITIS HERPETIFORMIS

Historical background

Dermatitis herpetiformis was first described in 1884 by Louis Duhring in Philadelphia, USA (Alexander 1975). He gave the name “dermatitis herpetiformis” to this blistering skin disorder, because “herpetiformis” described what he thought was the most characteristic feature of the disease. The next important finding was made at the early 1950s, when dapsone was shown to control the rash (Kruizinga & Hamminga 1953). Another landmark in the history of dermatitis herpetiformis was the demonstration of granular IgA deposits in the papillary dermis by immunofluorescence examination (van der Meer 1969). This finding suggested that the disorder had an autoimmune background and made it possible to differentiate dermatitis herpetiformis from other blistering autoimmune skin diseases such as pemphigoid. At the same time, jejunal biopsy screening showed that about 70% of patients with dermatitis herpetiformis had a mostly asymptomatic enteropathy (Marks et al. 1966). It was soon demonstrated that the enteropathy was caused by wheat gluten and therefore indistinguishable from that of coeliac disease (Fry et al. 1969). Furthermore, it was shown that the rash, too, responded to a gluten-free diet when this was followed strictly for several months (Fry et al. 1973, Reunala et al. 1977). In addition to gluten-sensitive enteropathy, dermatitis herpetiformis and coeliac disease were shown to have a common immunogenetic link, i.e. they were both associated with the same HLA antigen (Katz et al. 1972). It is now known that about 90% of patients with dermatitis herpetiformis and coeliac disease have the HLA DQ2 alleles DQA1*0501 and DQB1*02, the frequency of which in the general population is about 20-30% (Spurkland et al. 1997). Most of the remaining patients express the HLA DQ8 encoded by DQA1*03, DQB1*0302 alleles (Polvi et al. 1998). The immunogenetic evidence further substantiates that dermatitis herpetiformis belongs to the spectrum of coeliac disease and is not merely an organ-specific immunological disorder, like type 1 diabetes, which occurs in association with coeliac disease (Corazza et al. 1993).

Clinical picture and diagnosis

The principal symptom in dermatitis herpetiformis is an itchy blistering rash with the most common predilection sites being the elbows, knees, buttocks and scalp. In severe disease the lesions may occur anywhere on the skin. The blisters are small, resembling those caused by herpes simplex virus infection, and often eroded or crusted because of intense itching and scratching. In addition, erythema and even urticarial lesions may be seen. The severity of the rash varies individually, with some patients having only mild symptoms and others having an extensive rash with intense pruritus. The rash runs a life-long course and spontaneous remissions have only rarely been reported in adolescents or old people on a normal gluten-containing diet (Garioch et al. 1994, Bardella et al. 2003). Despite the frequent gluten-sensitive enteropathy, only about 10% of patients with dermatitis herpetiformis suffer from gastrointestinal symptoms such as diarrhoea or flatulence (Reunala et al. 1984).

Once the suspicion of dermatitis herpetiformis has arisen from the clinical picture of the rash, the diagnosis is confirmed by the demonstration of pathognomonic granular IgA deposits in the papillary dermis by direct immunofluorescence (van der Meer 1969). These deposits seem to be present throughout the skin, although more intense in the predilection sites of the rash. The biopsy should preferably be taken from clinically normal-appearing skin close to the active lesion (Zone et al. 1996).

A non-specific subepidermal bulla is seen when the histopathological specimen is taken from a dermatitis herpetiformis blister. If the specimen is taken from an early non-blistering skin lesion, it shows typical papillary microabscesses with an accumulation of neutrophils and some eosinophils (Alexander 1975).

The main differential diagnosis is linear IgA disease, which resembles dermatitis herpetiformis both clinically and histopathologically. In linear IgA disease, however, direct immunofluorescence examination shows a homogeneous IgA band along the dermo-epidermal junction whereas in dermatitis herpetiformis the granular IgA deposits are seen below the dermo-epidermal junction.

Treatment with gluten-free diet and dapsone

The treatment of choice for dermatitis herpetiformis is a life-long gluten-free diet. This means the permanent withdrawal of wheat, barley and rye from the diet. Oats has recently been shown to be tolerated by patients with both coeliac disease and dermatitis herpetiformis (Janatuinen et al. 1995, Hardman et al. 1997, Reunala et al. 1998). In dermatitis herpetiformis, a gluten-free diet controls the rash and allows the jejunal mucosa to recover (Reunala et al. 1977, Reunala 1978, Garioch et al. 1994). It takes, however, several months until the rash responds to the diet (Reunala et al. 1977, Garioch et al. 1994). Therefore, after diagnosis patients with an active rash require additional treatment with dapsone (Reunala et al. 1977, Leonard & Fry 1991).

Dapsone is a drug with antibacterial properties which was initially used in the treatment of leprosy. Dapsone is now known to have also anti-inflammatory effects by inhibiting the myeloperoxidase pathway in the neutrophils. It is effective against dermatitis herpetiformis, linear IgA disease and several other inflammatory skin conditions (Wolf et al. 2002). Dapsone clears the rash in dermatitis herpetiformis within a few days, but has no effect on the enteropathy. The initial daily dose of dapsone is usually from 25 mg to 100 mg. After two to three months on a gluten-free diet the dose can be tapered off and after two years on average on a strict gluten-free diet dapsone can be stopped (Leonard & Fry 1991, Garioch 1994).

Dapsone is usually well tolerated, but especially haematological adverse effects may cause problems. Haemolysis and methaemoglobinaemia are dose-related and agranulocytosis is a very rare event at the beginning of the treatment. Neuropathies may also appear during dapsone treatment when high daily doses are used for long periods (Wolf et al. 2002).

COELIAC DISEASE

Clinical features

Samuel Gee described the classical clinical features of coeliac disease in 1888. A Dutch paediatrician D.W. Dicke reported in 1953 that removal of wheat from the diet alleviated the symptoms. A few years later the peroral small-intestinal biopsy technique was introduced and it became possible to make a diagnosis of coeliac disease by showing villous atrophy in the small-intestinal mucosa (Cooke & Holmes 1984).

The classical symptoms of coeliac disease are diarrhoea, malabsorption and, in children, failure to thrive. During the last 20 years the classical presentation of coeliac disease has become rare especially in children. Nowadays, gastrointestinal symptoms are often mild, such as abdominal pain in children or flatulence in adults. Patients with atypical symptoms may present with only low haemoglobin, reduced bone mineral density, musculoskeletal or neurological symptoms or even with infertility. The condition is also often subclinical or even totally asymptomatic, i.e. “silent” (Mäki & Collin 1997, Collin et al. 1997).

There are also individuals with “latent” coeliac disease; they have initially a normal villous architecture and usually inflammatory changes such as increased intraepithelial lymphocyte infiltration in the small-intestinal mucosa, but develop classical coeliac disease later (Weinstein 1974, Collin et al. 1993). The present knowledge of the variable clinical features has led to the concept of a “coeliac disease iceberg”. The part above the surface consists of the patients with clinically visible symptoms, and the greater part hidden under the surface of the individuals with silent or latent coeliac disease (Catassi et al. 1996).

Diagnosis of gluten-sensitive enteropathy

In normal intestinal mucosa the villi are long and finger-shaped. In coeliac disease, dietary gluten induces inflammation and injury in the small-intestinal mucosa. The characteristic abnormalities in the

small-intestinal mucosa are villous atrophy, crypt hyperplasia and an increased number of IELs (Ferguson and Murray 1971, Kuitunen et al. 1982).

In coeliac disease, the small-intestinal mucosal damage develops gradually from a normal villous architecture to villous atrophy with crypt hyperplasia. The mucosal changes are divided (Marsh classification) into four classes according to the degree of injury. Class 0 is normal mucosa. The early lesion (Marsh 1) comprises lymphocyte infiltration into the epithelium and lamina propria. Thereafter the crypts elongate with or without minor shortening of villi (Marsh 2), and the lesion eventually progresses into severe partial or subtotal villous atrophy (Marsh 3) diagnostic to coeliac disease (Marsh 1992).

As stated above, the immunological process in the small-intestinal mucosa in coeliac disease can start already before the diagnostic villous atrophy has developed. An increased density of IELs has been regarded as an indication of ongoing immune response triggered by gluten both in coeliac disease and dermatitis herpetiformis (Halstensen et al. 1989, Savilahti et al. 1992). The IELs in coeliac disease and dermatitis herpetiformis are mainly α/β TcR-positive, but also the number of γ/δ TcR-positive cells is typically higher than in non-coeliac individuals (Ferguson et al. 1976, Corazza et al. 1984, Savilahti et al. 1992). The increase of γ/δ TcR-positive cells has been considered to be a typical finding for coeliac disease and dermatitis herpetiformis (Halstensen et al. 1989, Savilahti et al. 1992). These cells can be found even before villous atrophy develops (Mäki et al. 1991a, Iltanen et al. 1999). However, an increase of γ/δ TcR-positive cells is not fully specific for gluten-sensitive enteropathy but is also seen e.g. in children with cow's milk allergy (Spencer et al. 1991, Chan et al. 1993) and in subjects without coeliac-type HLA (Kaukinen et al. 2000).

According to the current criteria of the European Society for Paediatric Gastroenterology and Nutrition (ESPGAN), the diagnosis of coeliac disease in patients with typical symptoms can be based on a single small-intestinal biopsy showing characteristic subtotal or partial villous atrophy and on the disappearance of symptoms after adherence to a gluten-free diet (Walker-Smith et al. 1990). The criteria require a second small-intestinal biopsy in asymptomatic patients to confirm histological recovery after a gluten-free dietary treatment. The criteria do not include early or latent coeliac disease and should therefore be revised.

Serological findings

In patients with coeliac disease and dermatitis herpetiformis, gluten induces an immunological inflammation in the intestinal mucosa and, as a consequence, several IgA antibodies appear in the blood stream. The measurement of these antibodies can be used in coeliac disease case-finding and screening, and also in controlling dietary compliance in patients with coeliac disease and dermatitis herpetiformis.

IgA- and IgG-class antigliadin antibodies are most often determined by enzyme-linked immunosorbent assay (ELISA) (Vainio et al. 1983). The sensitivity and specificity of antigliadin antibodies are poor and the test has been replaced by antiendomysium and anti-tissue transglutaminase tests.

IgA-class endomysium antibodies are directed against the collagenous matrix of human and monkey tissues. They are detected by the immunofluorescent method using monkey esophagus or human umbilical cord as a substrate (Chorzelski et al. 1983, Ladinser et al. 1994). In coeliac disease and dermatitis herpetiformis the sensitivity and specificity of the IgA-class endomysium antibody test has been shown to be high: the sensitivity has ranged from 93% to 100% and the specificity from 99% to 100% (Reunala et al. 1987, McMillan et al. 1991, Ferreira et al. 1992, Vogelsang et al. 1995, Carroccio et al. 2002).

Tissue type transglutaminase (TG2) has been identified as the main endomysium autoantigen in coeliac disease (Dieterich et al. 1997). TG2 is an intracellular enzyme which is present ubiquitously in different tissues including those of the small bowel. Gliadin can also be a substrate for TG2 and after deamidation gliadin peptides bind effectively to HLA-DQ2 molecules on antigen presenting cells (Molberg et al. 1998). The measurement of IgA-class TG2 antibodies by ELISA is a new and simple method of screening gluten-sensitive enteropathy in coeliac disease and dermatitis herpetiformis (Dieterich et al. 1998 and Sulkanen et al. 1998). The sensitivity of the ELISA test based on human recombinant TG2 has varied from 90% to 100% and the specificity from 96% to 100% (Castellino et al. 2000, Sardy et al. 2000, Fabiani & Catassi 2001, Bonamico et al. 2001, Leon et al. 2001, Carroccio et al. 2002).

The prevalence of selective IgA deficiency in patients with coeliac disease is about 2% and in these patients gluten-sensitive enteropathy can be screened with IgG-class TG2 antibody measurements (Cataldo et al. 1997, Korbonay-Szabo et al. 2003).

Gluten-free dietary treatment

The treatment for coeliac disease is a life-long gluten-free diet. Gluten can be defined as a rubbery, dough-forming protein that remains when wheat flour is washed to remove the starch. The major protein fractions of wheat gluten are gliadins, which are soluble in alcohol, and glutenins, which are insoluble. In general, the alcohol-soluble protein fractions of different cereals are called prolamins. The prolamins of barley are called hordein, that of rye secalin and of oats avenin (Stern et al. 2001). Wheat, barley and rye prolamins induce damage in the small-intestinal mucosa in coeliac disease and dermatitis herpetiformis, whereas oats has been shown to be harmless (Janatuinen et al. 1995, Reunala et al. 1998).

A complete recovery of the small-intestinal mucosa in coeliac disease can take more than a year even on a strict gluten-free diet (Grefte et al. 1988, Kaukinen et al. 1999a). The usual reason for poor clinical or mucosal response is incomplete compliance in both coeliac disease and dermatitis herpetiformis (Baker et al. 1975, Mayer et al. 1991, Leonard & Fry 1991). Patients with coeliac disease vary in their sensitivity to gluten. In general, patients with dermatitis herpetiformis seem to tolerate smaller amounts of gluten than those with coeliac disease (Garioch et al. 1994, Stern et al. 2001). The concept of a strict gluten-free diet is debatable. In many countries, as in Finland, wheat starch-containing, gluten-free flour and products made from it are generally allowed in a gluten-free diet. These products may contain minute amounts of gluten (Collin et al. 2004). The continuous use of a wheat starch-containing gluten-free diet has recently been shown not to affect the well-being of patients with coeliac disease and dermatitis herpetiformis and not to cause any small-intestinal mucosal damage (Kaukinen et al. 1999a, Selby et al. 1999, Lohiniemi et al. 2000, Peräaho 2003).

A gluten-free diet has been reported to protect against complications of coeliac disease and dermatitis herpetiformis such as malignancies, osteoporosis and miscarriages (Holmes et al. 1989, Molteni et al. 1990, Lewis et al. 1996, Sategna-Giudetti et al. 2000, Eliakim & Sherer 2001). This gives one more reason to recommend a strict gluten-free diet to patients with coeliac disease.

EPIDEMIOLOGY AND PATHOGENETIC ASPECTS OF COELIAC DISEASE AND DERMATITIS HERPETIFORMIS

Epidemiology

The prevalence of coeliac disease was previously estimated to be about 1:1000, but several recent screening studies both in Europe and the USA have shown a prevalence as high as 1:300-1:100 (Kolho et al. 1998, Ivarsson et al. 1999, Volta et al. 2001, Mäki et al. 2003, Fasano et al. 2003). Many coeliac disease patients present only minor symptoms, if any, and would therefore remain undiagnosed if not actively screened by serological tests. Coeliac disease can appear at any age, and in adults it is more common in women than in men (Mäki & Collin 1997).

The prevalence of dermatitis herpetiformis is not known as well as that of coeliac disease. There have been reports from the Nordic countries, Scotland and Utah, USA, with prevalences ranging from 11/100 000 to 66/100 000 (=1:1500) (Table 1). The common age at onset is 30 - 40 years, but it can appear at any age (Reunala 2001). In Finland, dermatitis herpetiformis seems to be slightly more common in men than in women (Mäki & Collin 1997).

Table 1. Studies on the prevalence and incidence of dermatitis herpetiformis.

Author	Country	Prevalence / 100 000	Incidence / 100 000 / year
Reunala & Lokki 1978	Finland	10.4	1.3
Moi 1984	Central Sweden	39	0.86-1.45
Mobacken et al. 1984	Gothenburg, Sweden	22.9	1.1
Gawkrodger et al. 1984	Scotland	11.5	NK
Christensen et al. 1986	Southern Sweden	20-25	1.05-1.13
Smith et al. 1992	Utah, USA	11.2	0.98
Collin et al. 1997	Tampere, Finland	66	3

NK=not known

Autoimmune pathogenesis of coeliac disease

The pathogenetic mechanisms in coeliac disease and dermatitis herpetiformis are still in many respects poorly understood. It is known that genetic, environmental and immunological factors are all involved. The principal environmental cause is dietary gluten, which is essential for the development of the disease. At the moment, no other environmental factors have been found.

The immunological mechanisms involved in the mucosal damage in coeliac disease comprise both mucosal cellular and humoral immune systems (Trier 1991, Sollid et al. 1997). Dieterich et al. (1997) showed recently that TG2 is the predominant autoantigen for respective IgA-class antibodies in coeliac disease. This ubiquitous enzyme, which is present also in the intestinal mucosa, seems to play a critical role in controlling cell homeostasis, regulating the cell cycle through its involvement in proliferation, differentiation and apoptosis. In coeliac disease, TG2 is directly involved in the pathogenesis of the disease, influencing both the humoral and cellular response (Reif & Lerner 2004).

The reaction cascade in the small intestine is triggered by ingested gluten (gliadins). Digested gliadin peptides pass through the intestinal epithelia and enter the lamina propria. Gliadin-specific HLA DQ2 and DQ8 restricted T cells are present in the small-intestinal mucosa of a patient with coeliac disease. Antigen-presenting cells present the digested gliadin peptide to CD4⁺ T cells via their HLA DQ molecules. There is evidence suggesting that TG2 modifies gliadin peptides through deamidation of glutamine residues to negatively charged glutaminic acid, which then facilitates the binding of gliadin peptides to the peptic groove of HLA DQ2 and DQ8 molecules on the antigen-presenting cells (Lundin et al. 1993, Molberg et al. 1998). This results in increased T-cell activation and proliferation into T helper (Th)1 and Th2 subtypes. Th1 cells produce tumour necrosis factor- α (TNF α) and interferon- γ . TNF α induces secretion of matrix metalloproteinases (MMPs), and it has been suggested that these MMPs may cause matrix breakdown and lead to villous atrophy (Schuppan 2000). Th2 cells activate B cells to produce IgA antibodies against TG2 and gliadin. *In vitro* and *in vivo* evidence suggests that the IgA antibody binding to TG2 seems to affect the function of this enzyme, which leads via impaired activation of transforming growth factor- β to altered intestinal crypt epithelial differentiation and then finally to villous atrophy (Halttunen & Mäki 1999, Korponay-Szabo et al. 2004) (Figure 1).

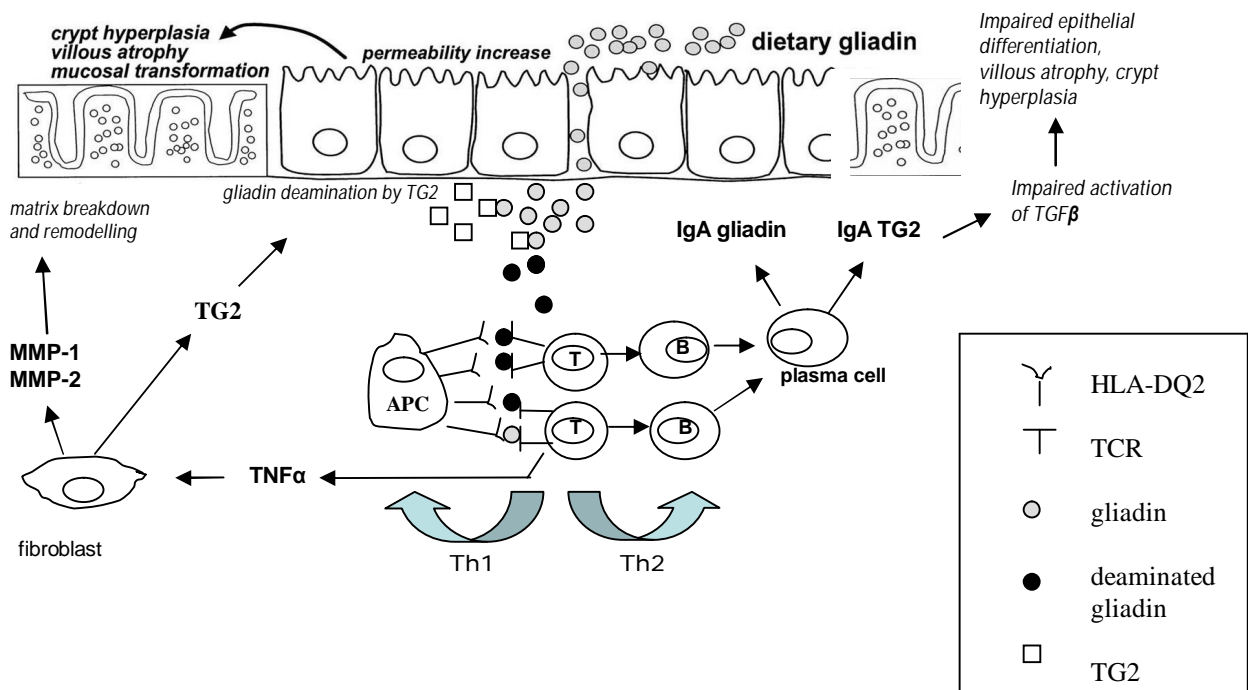

Figure 1. Summary of theories of the pathogenesis of small-intestinal damage in coeliac disease.

Adapted from Schuppan (2000).

APC=antigen presenting cell

TG2=tissue type transglutaminase.

Th=T helper lymphocyte

TNFα=tumor necrosis factor α

MMP=matrix metalloproteinase

TGFβ=transforming growth factor β

IgA deposits and blister formation in dermatitis herpetiformis

In dermatitis herpetiformis, granular IgA deposits are present in dermal papillae (van der Meer 1969). They are deposited in close association with microfibrillar bundles of elastic fibres, and greater amounts seem to be present together with complement near active lesions (Zone et al. 1996). There has long been a hypothesis suggesting that circulating immune complexes originating from the gut and composed of IgA antibodies attached to an antigen, possibly gluten, could be deposited in dermatitis herpetiformis skin (Seah et al. 1971). Circulating IgA immune complexes can be detected in the sera of patients with dermatitis herpetiformis, and increased levels have been found after wheat ingestion (Zone et al. 1982). However, similar IgA immune complexes are also seen in the sera of patients with coeliac disease who have neither skin disease nor cutaneous IgA deposits.

A recent study by Sardy et al. (2002) showed that IgA is deposited in co-localization with epidermal transglutaminase (TG3) in the dermal papillae. They also showed that patients with dermatitis herpetiformis, in contrast to patients with coeliac disease, have IgA transglutaminase antibodies with a higher affinity to TG3 than to TG2. They hypothesized that patients with dermatitis herpetiformis first develop silent coeliac disease and then, after a long-lasting gliadin exposure, a subpopulation of IgA TG2 antibodies cross-reacting with TG3 in the skin would develop. This hypothesis would explain why dermatitis herpetiformis develops in only a part of the patients with coeliac disease.

The formation of clinically visible blisters in dermatitis herpetiformis starts with formation of neutrophil microabscesses at the summits of dermal papillae. These are quickly transformed by oedema into microvesicles which then coalesce to form a unilocular subepidermal bulla. The split occurs in the lamina lucida and the whole process of blister formation takes about 24 hours (Klein et al. 1983). Before the neutrophils appear, there is accumulation of CD4⁺ T cells which express both interleukin (IL)-4 and IL-5 mRNA (Reitamo et al. 1981, Caproni et al. 1998). IL-8, which is a strong chemoattractant for neutrophils, is expressed in the basal layer of the epidermis and granulocyte macrophage colony stimulating factor, an activator of neutrophils and inducer of IgA receptors, is also activated in the dendritic cells in the dermoepidermal junction (Graeber et al. 1993). Thus the neutrophils are able to migrate into the upper dermis, may bind to IgA in the dermal papillae, and release enzymes causing tissue damage and blister formation. Keratinocytes and macrophages are also able to produce enzymes such as MMP-3 and MMP-12 important for matrix degradation in the dermo-epidermal junction (Airola et al. 1997).

GENETIC FINDINGS IN COELIAC DISEASE AND DERMATITIS HERPETIFORMIS

Family studies

Familial clustering of coeliac disease has been recognized for a long time. McDonald et al. (1965) published the first family study on coeliac disease in which a small intestinal biopsy finding was the criterion for the disease. Since then several other family studies on coeliac disease have been carried out, and the prevalence of coeliac disease among first-degree relatives has varied from 2.9% to 22% (Table 2).

The tendency of dermatitis herpetiformis to run in families has not been as clear as that of coeliac disease. There are only four studies on familial dermatitis herpetiformis, and in only one of them was the prevalence of dermatitis herpetiformis among first-degree relatives systematically studied. Reunala (1976) examined six families, which included 11 members with dermatitis herpetiformis and three with coeliac disease. Jejunal biopsy performed on 20 relatives disclosed eight additional cases with coeliac disease, but skin biopsy failed to reveal IgA deposits in any of the 44 relatives studied. Leonard et al. (1983a) reported that one of the 109 patients with dermatitis herpetiformis had an affected first-degree relative. He was also unable to find more cases among the 20 relatives by performing skin biopsies for IgA deposits. Meyer & Zone (1987) obtained family histories from 92 patients with dermatitis herpetiformis. They found six (0.8%) first-degree relatives with dermatitis herpetiformis, but did not search for coeliac disease among the relatives. Reunala (1996) carried out a large family study of 999 Finnish patients with dermatitis herpetiformis, and found that 10.5% of the patients had an affected first-degree relative. The disease of the relative was either coeliac disease or dermatitis herpetiformis, but no estimate was given of the prevalence or incidence among the relatives.

Table 2. Studies on familial occurrence of coeliac disease

Author	Country	Families with CD n	First-degree relatives n	First-degree relatives biopsied n	First-degree relatives affected %
MacDonald et al. 1965	USA	17	NK	62	5 (11)*
Mylotte et al. 1974	Ireland	28	195	114	6 (11)*
Stokes et al. 1976	UK	115	526	182	8 (22)*
Auricchio et al. 1988	Finland and Spain, Italy	51 192	172 487	152 56	8.8 5.7
Shah et al. 1990**	UK	162	861		2.9
Mäki et al. 1991b	Finland	42	148	122	9 (11)*
Korponay-Szabo et al. 1998	Hungary	396	943		8.5
Farre et al. 1999	Spain	227	675		5.5

NK=not known

*In parentheses the percentage of biopsied relatives affected

**A questionnaire study

Monozygous twins

Twin studies comparing the concordance and discordance rates of monozygous and dizygous twin pairs can be used in assessing the relative effects of genetic and environmental factors for the outbreak of a disease. A high genetic effect is suggested when the concordance rate in monozygous twins is higher than that in dizygous twins. Provided that there is no difference in concordance rates between monozygous and dizygous twins, the role of genes is assumed to be low and that of common environment high (Salvetti et al. 2000).

A high concordance rate for coeliac disease is suggested by numerous case reports on monozygous twins, but they all are based on one or two twin pairs (Khuffash et al. 1984, Polanco et al. 1987, Salazar de Sousa et al. 1987, Henker et al. 1989, Holtmeier et al. 1997). Three pairs of monozygous twins with dermatitis herpetiformis have been reported; one of these pairs was concordant for both skin disease and gluten-sensitive enteropathy (Anstey et al. 1991), while the other two pairs were discordant for skin disease but concordant for enteropathy (Jepsen & Ullman 1980, Kosnai et al. 1985).

HLA and gene studies

Susceptibility to coeliac disease and dermatitis herpetiformis is known to be largely determined by genetic factors. Both diseases have a strong genetic association to the HLA region on chromosome 6. Approximately 90% of patients with coeliac disease or dermatitis herpetiformis have the DQ2 heterodimer encoded by the alleles DQA1*0501 and DQB1*02 (Sollid et al. 1989, Spurkland et al. 1997). Most of the DQ2-negative patients with coeliac disease or dermatitis herpetiformis have the HLA DQ8 haplotype encoded by DQA1*03 and DQB1*0302, or they may carry only one of the alleles coding DQ2 (Spurkland et al. 1992, Polvi et al. 1998). Patients without these alleles appear to be very rare (Polvi et al. 1998, Karell et al. 2003).

The effect of DQ2 homozygosity versus DQ2 heterozygosity has also been studied, and it seems that although one copy of DQ2 is sufficient for the onset of coeliac disease, people homozygous for DQ2 carry a higher risk for coeliac disease than heterozygous ones. The number of risk alleles may also influence the age at onset and the severity of the disease (Ploski et al. 1993, Congia et al. 1994).

HLA may not be the only predisposing genetic factor in coeliac disease and dermatitis herpetiformis. The frequency of HLA DQ2 is about 20-30% in the general European population (Sollid et al. 1989, Polvi et al. 1996), which means that only a minority of people with HLA DQ2 will ever develop coeliac disease or dermatitis herpetiformis. Also the concordance rate of only 30-50% in HLA-identical twins (Mearin et al. 1983) suggests that additional, probably non-HLA genes are involved in the pathogenesis of coeliac disease and dermatitis herpetiformis. Genome-wide linkage analyses have revealed other candidate genes in several chromosomes (Zhong et al. 1996, Greco et al. 1998, King et al. 2000, Holopainen et al. 2001), but so far the linkage of coeliac disease to HLA DQ has been the highest and unanimous.

ASSOCIATED DISEASES IN COELIAC DISEASE AND DERMATITIS HERPETIFORMIS

Type 1 diabetes and other associated disorders

The association between type 1 diabetes and coeliac disease was recognized over 30 years ago (Visakorpi 1969). After that, the frequency of type 1 diabetes in patients with coeliac disease has been reported to be 1.4% - 7.4% (Cooper et al. 1978, Snook et al. 1989, Collin et al. 1994, Bottaro et al. 1999). The occurrence of coeliac disease in patients with type 1 diabetes has been studied by serological screening and approximately 4% of the patients have had associated coeliac disease (Collin et al. 2002). The concomitant occurrence of coeliac disease and type 1 diabetes is at least partly explained by a common genetic background. Susceptibility both to coeliac disease and type 1 diabetes is associated with HLA DR3-DQ2 and HLA DR4-DQ8 haplotypes (Sollid et al. 1989, Buzetti et al. 1998). Dermatitis herpetiformis shares the same genetic background with coeliac disease (Spurkland et al. 1997) suggesting that increased prevalence of type 1 diabetes could be expected also in patients with dermatitis herpetiformis. There is, however, only one previous study showing heterogeneity of the HLA risk antigens in dermatitis herpetiformis patients with type 1 diabetes (Reijonen et al. 1991) and another study reporting a 1% frequency of type 1 diabetes in a series of 305 patients with dermatitis herpetiformis (Reunala & Collin 1997).

Coeliac disease and dermatitis herpetiformis have been reported also in association with many other autoimmune disorders. The frequency of autoimmune thyroid disease has been from 0.2% to 11% in patients with coeliac disease (Midhagen et al. 1988, Collin et al. 1994, Bottaro et al. 1999) and 4.3% in one study in patients with dermatitis herpetiformis (Reunala & Collin 1997). Sjögren's syndrome was reported in about 3% of patients with coeliac disease and 1% of patients with dermatitis herpetiformis (Collin et al. 1994, Reunala & Collin 1997). Autoimmune liver diseases, i.e. autoimmune hepatitis, primary biliary cirrhosis, autoimmune cholangitis and primary sclerosing cholangitis, also seem to occur in association with coeliac disease and dermatitis herpetiformis (Gabrielsen & Hoel 1985, Walton & Walton 1987, Lewis et al. 1993, Davison 2002, Volta et al. 2002). A possible association between coeliac disease and Addison's disease was earlier based on case reports, but recently a screening study on Addison's disease found five (12.5%) patients suffering also from coeliac disease (O'Leary 2002). Selective IgA deficiency is known to be ten times more common in patients with coeliac disease than in the general population (Collin & Mäki 1994). Autoimmune skin diseases consist of vitiligo found in 1.3% and alopecia areata found in 0.3% of 305 patients with dermatitis herpetiformis, but in none of 383 patients with coeliac disease (Reunala & Collin 1997). The frequency of coeliac disease has been reported to be 1.2% among 256 patients with alopecia areata, but this study did not include any control group (Corazza et al. 1995).

Neurological disorders occurring in patients with coeliac disease include ataxia, cerebral calcifications with occipital lobe epilepsy and dementia (Collin et al. 1991, Gobbi et al. 1992, Hadjivassiliou et al. 1998), whereas no such associations have been found in dermatitis herpetiformis (Wills et al. 2002). Bone mineral density is often decreased in coeliac disease and there may be a slightly increased risk for bone fractures in these patients. (Valdimarsson et al. 1994, Walters 1994, Kemppainen et al. 1999, West et al. 2003). The mechanisms underlying the reduced bone mineral density might include calcium and vitamin D malabsorption, secondary hyperparathyroidism and failure to attain maximum bone density in childhood. Dental enamel defects of permanent teeth originating from childhood are also often seen in patients with coeliac disease and dermatitis herpetiformis (Aine 1996).

Lymphoma and other malignancies

The most severe complication of coeliac disease and dermatitis herpetiformis is lymphoma and other malignancies. The association between coeliac disease and lymphoma was reported already 40 years ago and the first case of dermatitis herpetiformis with lymphoma soon after that (Gough et al. 1962, Grone & Nordöy 1970). The first systematic studies reported a very high relative risk, i.e. 40, for lymphoma in coeliac disease and as high as 100 in dermatitis herpetiformis (Holmes et al. 1976, Leonard et al. 1983b). Thereafter, the reported relative risks have been much lower though significantly increased (Tables 3 and 4).

Table 3. Studies on the frequency of lymphoma in series of patients with coeliac disease

Author	Country	n	Years of collection	Lymphomas n	Relative risk
Holmes et al. 1976	UK	210	1941-1974	14 (6.7%)	-
O'Driscoll et al. 1982	Ireland	198	1969-1981	10 (5.1%)	-
Nielsen et al. 1985	Denmark	100	1964-1982	3 (3.0%)	-
Holmes et al. 1989	UK	210	1941-1985	216 (7.6%)	42.7
Collin et al. 1994	Finland	335	1980-1990	0	-
Ilyas et al. 1995	UK	166	1969-1994	13 (8%)	-
Askling et al. 2002	Sweden	11019	1964-1995	44 (0.4%)	SIR* 5.9

*Standardized incidence ratio

Table 4. Studies on the frequency of lymphoma in series of patients with dermatitis herpetiformis.

Author	Country	n	Years of collection	Lymphomas n	Relative risk
Leonard et al. 1983b	UK	109	1969-1981	3 (2.8%)	100
Gawkrodger et al. 1984	Scotland	76	1971-1981	2 (2.6%)	-
Christensen et al. 1986	Sweden	96	1979-1983	0	-
Swerdlow et al. 1993	UK	152	1950-1985	1 (0.7%)	-
Sigurgeirsson et al. 1994	Sweden	976	1963-1983	13 (1.3%)	5.4 / 4.5*
Collin et al. 1996	Finland	305	1970-1992	4 (1.3%)	-
Lewis et al. 1996	UK and Finland	487	1969-1993	8 (1.6%)	SIR** 10.3
Askling et al. 2002	Sweden	1354	1964-1995	7 (0.5%)	SIR 1.9

*In men / in women with dermatitis herpetiformis

**Standardized incidence ratio

The most established lymphoma associated with coeliac disease is EATL (Isaacson et al. 1985). This rare lymphoma accounts for less than 0.5% of new non-Hodgkin lymphomas and its outcome is poor (Egan et al. 1995, Gale et al. 2000). B-cell lymphomas in the gut or lymph nodes have also been described in coeliac disease and dermatitis herpetiformis, but the association is far less clear than that of EATL (Sigurgeirsson et al. 1994, Lewis et al. 1996, Askling et al. 2002, Catassi et al. 2002). There are two previous studies, one performed in 210 patients with coeliac disease and the other in 483 patients with dermatitis herpetiformis, suggesting that a strict gluten-free diet gives protection against the development of lymphoma (Holmes et al. 1989, Lewis et al. 1996).

The exact mechanism of the development of lymphoma in coeliac disease and dermatitis herpetiformis is unknown. Intestinal T-cell lymphomas complicating coeliac disease probably derive from the intestinal IELs (Murray et al. 1995, Carbonnel et al. 1998, Cellier et al. 2000). It may be that, in some coeliac disease patients, the inflammatory process in the intestine converts to a monoclonal process which may subsequently progress to overt T-cell lymphoma. This clonal conversion of IELs may be due to long-lasting antigenic stimulation of lymphocytes by gluten (Wright et al. 1991, Ashton-Key et al. 1997).

In coeliac disease, an increased risk for small-intestinal adenocarcinoma, oesophageal carcinoma and oropharyngeal carcinoma has also been reported. The relative risk of small-intestinal adenocarcinoma in coeliac disease has been reported to be as high as 82.6 (Swinson et al. 1983) and that of cancers of the mouth, pharynx and oesophagus in coeliac disease patients not on a strict gluten-free diet 22.7 (Holmes et al. 1989). In dermatitis herpetiformis no such increase of gastrointestinal cancers has been observed (Leonard et al. 1983b, Christensen et al. 1986, Collin et al. 1996). However, dermatitis herpetiformis has been reported in association with many other carcinomas, including carcinomas of the lung, prostate and colon (Leonard et al. 1983b, Swerdlow et al. 1993, Collin et al. 1996), but the precise risk for these is unknown. Interestingly, the all-cause mortality of patients with dermatitis herpetiformis has, however, been reported to be slightly reduced in two different studies (Swerdlow et al. 1993, Collin et al. 1996), which is in contrast to coeliac disease (Logan et al. 1989, Corrao et al. 2001).

AIMS OF THE PRESENT STUDY

Coeliac disease has a well known tendency to run in families, and coeliac disease patients are also known to carry a high risk of contracting autoimmune diseases, like type 1 diabetes, and lymphoma. In dermatitis herpetiformis, which has been suggested to be a cutaneous phenotype of coeliac disease, evidence of familial occurrence and associated diseases has been scanty in the patients and non-existent in their first-degree relatives. The specific aims of this study were:

1. To study the prevalence and incidence of dermatitis herpetiformis and coeliac disease among first-degree relatives of patients with these diseases.
2. To examine the concordance of dermatitis herpetiformis and coeliac disease in monozygous twins.
3. To investigate the occurrence of type 1 diabetes in patients with dermatitis herpetiformis and their first-degree relatives, and to study whether the rash in patients with dermatitis herpetiformis and associated type 1 diabetes responds to a gluten-free diet similarly to the rash in patients having dermatitis herpetiformis only.
4. To study the occurrence of lymphoma and its subtypes in patients with dermatitis herpetiformis and their first-degree relatives, and to examine whether dermatitis herpetiformis patients with lymphoma had not adhered to a gluten-free diet as well as those without lymphoma.

PATIENTS AND METHODS

PATIENTS AND CONTROLS

The patients with dermatitis herpetiformis or coeliac disease and their first-degree relatives included in the four studies (I-IV) of the present thesis are shown in Table 5.

Table 5. Study designs, patients with dermatitis herpetiformis (DH) or coeliac disease (CD), their first-degree relatives and participating dermatitis herpetiformis controls.

Study design	Patients and relatives	N (men/women)	Mean age at diagnosis in years (range)	Sex- and age-matched case controls
I Prevalence and incidence of DH and CD in first-degree relatives	DH patients CD patients First-degree relatives	281 (137/144) 380 (93/287) 3158	40 (5-84) 34 (0.3-84)	
II Concordance of DH and CD in monozygous twins	Monozygous twins	6 (2/4)	27 (17-44)	
III Occurrence of type 1 diabetes (T1D) in DH patients and first-degree relatives	DH patients First-degree relatives	1104 (601/503) 1388		
Gluten-free diet analysis	DH patients with T1D	25 (15/10)	32 (17-56)	50 DH patients without T1D
IV Occurrence and typing of lymphoma in DH patients and first-degree relatives	DH patients First-degree relatives	1104 (601/503) 1265		
Gluten-free diet analysis	DH patients with lymphoma	11 (6/5)	41 (17-64)	22 DH patients without lymphoma

Dermatitis herpetiformis patients (I, III-IV)

The patients with dermatitis herpetiformis were recruited from special outpatient clinics of the Departments of Dermatology of Tampere University Hospital and Helsinki University Central Hospital where these patients were prospectively collected since 1969. Altogether 1104 patients with dermatitis herpetiformis were sampled, 341 from Tampere University Hospital and 763 from Helsinki University Central Hospital. The diagnosis of dermatitis herpetiformis was based on the clinical picture and the presence of granular IgA deposits in the skin. From 1982, serological screening of coeliac disease was performed routinely with IgA-class antigliadin and antireticulin antibody measurements (Vainio et al. 1983, Hällström et al. 1989), later with antigliadin and antiendomysium (Reunala et al. 1987) and finally with antigliadin and antitransglutaminase antibody determinations (Dieterich et al. 1999). Small-intestinal biopsy was offered to almost all newly diagnosed patients. At first it was taken with a Crosby capsule and later under gastroscopy.

Dapsone was prescribed to the patients with active rash and a gluten-free diet was introduced to all patients (Reunala et al. 1977). The patients were followed up in the outpatient clinics, usually at least for two years, to document their response to the gluten-free dietary treatment. During the follow-up, adherence to a gluten-free diet and the use of dapsone were recorded on a special form. Overall, 93% of the dermatitis herpetiformis patients treated at Tampere University Hospital adhered to a gluten-free diet and 85% of them were able to stop dapsone or decrease the daily dose of dapsone more than 50% (Collin et al. 1996).

Coeliac disease patients (I)

A series of 767 patients with coeliac disease was collected at the special outpatient clinic of the Department of Internal Medicine of Tampere University Hospital since 1980. The diagnosis of coeliac disease was based on the demonstration of subtotal or partial villous atrophy in small-intestinal biopsy. In addition, serum antibodies were measured for the majority of the patients since 1984. A gluten-free diet was introduced to all patients, and they were followed up in the outpatient clinic until mucosal recovery was evident.

Monozygous twins (II)

Six dermatitis herpetiformis patients with an apparently monozygous twin were recruited from a series of 1292 patients with dermatitis herpetiformis seen in 1969-1999. Two twin pairs were from Helsinki University Central Hospital, two from Tampere University Hospital, one from Turku University Hospital and one from Kuopio University Hospital. The occurrence of dermatitis herpetiformis and coeliac disease in the families of the 1292 patients was asked at diagnosis and during follow-up visits as described by Reunala (Reunala 1996). All monozygous twin pairs were re-examined in 1999 for adherence to a gluten-free diet, presence of rash or gastrointestinal symptoms, and IgA antibodies to gliadin and endomysium. The diagnosis of dermatitis herpetiformis was based on the demonstration of granular IgA deposits in the skin below the dermo-epidermal junction, and the diagnosis of coeliac disease on the demonstration of subtotal or partial villous atrophy in the small intestine.

Control patients (III, IV)

Two age- and sex-matched (± 5 years) patients with dermatitis herpetiformis but without type 1 diabetes were selected as case controls for each of 25 dermatitis herpetiformis patients with type 1 diabetes (Table 5, III).

To analyse how the dermatitis herpetiformis patients with lymphoma had adhered to a gluten-free diet, two dermatitis herpetiformis case controls were selected for each of the 11 dermatitis herpetiformis patients with lymphoma (Table 5, IV). The case controls were matched for sex and also for age of the index patient and the year of diagnosis (± 5 years).

Ethics

The study protocols were approved by the Ethics Committees of Tampere University Hospital and Helsinki University Central Hospital.

METHODS

Collection of associated disease and family data (I, III-IV)

The occurrence of any chronic disease, including type 1 diabetes and lymphoma, in the dermatitis herpetiformis patients and the occurrence of dermatitis herpetiformis and coeliac disease in the families were recorded systemically at diagnosis and during the follow-up visits on a special form as previously described (Reunala 1996, Reunala & Collin 1997). In addition, a specific questionnaire was sent in 1999 to 341 patients with dermatitis herpetiformis and 767 patients with coeliac disease belonging to the patient series collected prospectively at Tampere University Hospital. It included questions about the occurrence of any chronic disease or malignancy in the patients. Adherence to and strictness of a gluten-free diet was also asked as was the use of dapsone in the patients with dermatitis herpetiformis. The number of parents, siblings and children the patients had and who were still alive were recorded. Special questions about the occurrence of dermatitis herpetiformis, coeliac disease, diabetes or malignancies in the relatives were also included.

The questionnaire was returned by 287 (84%) patients with dermatitis herpetiformis and 411 (54%) patients with coeliac disease. Of these patients, six with dermatitis herpetiformis and 31 with coeliac disease had a relative who also returned the questionnaire. Owing to this, the final analysis of the occurrence of dermatitis herpetiformis and coeliac disease in the first-degree relatives was based on the data received from 281 patients with dermatitis herpetiformis and 380 with coeliac disease (Table 5, I). When the questionnaires were returned, the mean time from the diagnosis was 15 years (1-26) for the patients with dermatitis herpetiformis and 13 years (1-36) for those with coeliac disease.

The questionnaire was sent in 2002 also to 22 patients with dermatitis herpetiformis and associated type 1 diabetes. Of these, 20 (87%) returned the questionnaire (III).

Dermatitis herpetiformis and coeliac disease in first-degree relatives (I)

The 281 patients with dermatitis herpetiformis had 1265 and the 380 patients with coeliac disease 1893 first-degree relatives who were alive (Table 5). The relatives who were reported to be affected by either dermatitis herpetiformis or coeliac disease were registered. When the diagnosis of dermatitis herpetiformis (skin biopsy) and coeliac disease (small-intestinal biopsy) was not documented adequately, the relatives were personally contacted and the diagnosis further confirmed from medical records whenever needed.

The prevalence of dermatitis herpetiformis and coeliac disease among the relatives was recorded at the time the questionnaire was received, i.e. in 1999. The annual incidence of dermatitis herpetiformis and coeliac disease among the relatives was calculated from all new dermatitis herpetiformis and coeliac disease cases, which appeared in the relatives in the time frame each index patient was followed up.

Type 1 diabetes and lymphoma in first-degree relatives (III, IV)

To study the occurrence of type 1 diabetes in the first-degree relatives, the questionnaire data received from 304 dermatitis herpetiformis patients and comprising 1388 relatives was used. Diagnosis of type 1 diabetes was confirmed by personal contact and, when needed, also from medical records. To study the occurrence of lymphoma in the first-degree relatives, the questionnaire data received from 281 dermatitis herpetiformis patients and comprising 1265 relatives was used. In addition, lymphomas were also recorded from 560 first-degree relatives who were dead at the time when the questionnaire was received. The diagnosis of lymphoma was confirmed from hospital records, and also from the histopathological specimens when available. In addition, it was checked whether the relatives with lymphoma had been diagnosed as having dermatitis herpetiformis or coeliac disease.

Genetic analyses in monozygous twins (II)

For genetic analyses blood samples were drawn from each of the 12 twins. Eight microsatellite markers (D1S1589, D9S158, D10S1213, D14S617, D15S642, D16S403, D17S1293 and D18S851) from different chromosomes were typed using standard genotyping procedures. The HLA alleles were determined using the Lipa DRB1, DQB1 and DPB1 reverse dot blot kits (Innogenetics, Dartford, UK) and the Dynal DQA1 SSP kit (Dynal AS, Oslo, Norway).

Adherence to a gluten-free diet (III, IV)

To study whether the 25 patients with dermatitis herpetiformis and associated type 1 diabetes had adhered and responded to a gluten-free diet similarly to the 50 case controls with isolated dermatitis herpetiformis, the gluten-free diet data were collected from the follow-up forms and also from medical records. Adherence to the gluten-free diet was considered strict when there were no deviations from the diet, semi-strict when there were occasional deviations and poor if the patients admitted dietary deviations at least once a month. The daily dose of dapsons needed to control the rash at the beginning and during the gluten-free diet was also analyzed. The response to the gluten-free diet was recorded as good when the rash had disappeared and the patient had been able to stop the use of dapsons, moderate when the daily dose of dapsons could be reduced more than 50 % and no response when the dose remained above 50% of that used at the beginning of the gluten-free dietary treatment. In four patients with type 1 diabetes and eight patients with isolated dermatitis herpetiformis not using dapsons at all, the response to the diet was recorded as good when the rash had totally disappeared, moderate when some flare-ups occurred and no effect when the rash was continuously present.

To analyse whether the 11 dermatitis herpetiformis patients with lymphoma had adhered to a gluten-free diet similarly to the 22 case controls with dermatitis herpetiformis, the duration and strictness of the gluten-free diet were analysed from the follow-up forms and, when needed, also from hospital records. In each index case the time frame analysed was the period (in months) from the diagnosis of dermatitis herpetiformis to the diagnosis of lymphoma. The same time frame was analysed for each of the two case controls. The gluten-free diet was classified as strict when there were no faults, as

partial when there were occasional faults, i.e. less than once a week, and as a normal diet when the patient consumed gluten every week or did not adhere to a gluten-free diet at all.

Typing of lymphomas (IV)

Biopsy specimens from the dermatitis herpetiformis patients and their first-degree relatives with lymphoma were re-examined and classified according to the new WHO classification (Jaffe et al. 2001). Formalin-fixed and paraffin-embedded sections were stained with haematoxylin and eosin. Immunohistochemistry was performed by using monoclonal antibodies to identify T-cell (anti-CD3) and B-cell (anti-CD20) lymphomas. Epithelial cell markers (Cytokeratin PAN, Epithelial Membrane Antigen) were used to identify an anaplastic carcinoma which was negative in CD3 and CD20 staining.

Statistical analyses

In Study I, the incidence of dermatitis herpetiformis and coeliac disease among the first-degree relatives was compared to the incidence of these diseases in the population of Tampere (Collin et al. 1997) by calculating 95% confidence limits for the observed incidence. The Chi-squared test was used to compare the observed dermatitis herpetiformis and coeliac disease prevalences among the first-degree relatives of patients with dermatitis herpetiformis to those among the first-degree relatives of patients with coeliac disease.

In Study II, the probability that the twins were monozygous was calculated by assuming that a sib pair would have a probability of 0.25 to be identical in any fully informative locus. For eight unlinked loci studied, the probability was $(0.25)^8$. The casewise concordance rate (Cc) was calculated from $Cc = 2C / (2C + D)$, where C stands for the number of concordant and D for discordant twin pairs (MacGregor 2000).

In Study III, the prevalence of type 1 diabetes in patients with dermatitis herpetiformis and their first-degree relatives was calculated. The Chi-squared test with confidence intervals was used to compare the observed prevalences to that found in a previous series of patients with coeliac disease (Collin et al. 1994).

In Study IV, Rosner's test and confidence intervals adjusted by the Rosner procedure (Rosner 1982) were used to analyse whether adherence to a gluten-free diet differed between the 11 dermatitis herpetiformis patients with lymphoma and the 22 case controls without lymphoma. A P value below 0.05 was considered significant.

RESULTS

Dermatitis herpetiformis and coeliac disease in first-degree relatives (I)

A total of 51 (18.1%) of the patients with dermatitis herpetiformis and 73 (19.2%) of those with coeliac disease had at least one affected first-degree relative.

The combined prevalence of dermatitis herpetiformis and coeliac disease was 5.4% among the first-degree relatives of the patients with dermatitis herpetiformis and 5.5% among the first-degree relatives of the patients with coeliac disease (Table 6). In both patient series the relatives were affected more often by coeliac disease (3.9% and 4.7%, respectively; $p=0.26$) than by dermatitis herpetiformis (1.5% and 0.8%, respectively; $p=0.06$).

In the first-degree relatives of patients with dermatitis herpetiformis the combined disease incidence was 2.8/1000 relatives/year and in the relatives of patients with coeliac disease 3.0/1000 relatives/year. When this incidence was compared to that in the population of Tampere, i.e. 0.20/1000/year, the relatives had a 14.9 times higher incidence (95% confidence limits 12.5 to 17.8).

Table 6. Prevalence of coeliac disease (CD) and dermatitis herpetiformis (DH) in the first-degree relatives.

	<u>Relatives</u>	<u>All</u>	<u>Affected relatives</u>	
	n	n	with CD	with DH
			n	n
Patients with DH (n=281)	1265	68 (5.4%)	49 (3.9%)	19 (1.5%)
Patients with CD (n=380)	1893	104 (5.5%)	89 (4.7%)	15 (0.8%)

Fourteen (27%) patients with dermatitis herpetiformis and 24 (33%) with coeliac disease had in their families two or more affected first-degree relatives (I; Tables IV and V). In addition to the index case, one dermatitis herpetiformis family included four, another family three and 12 families two affected members. Similarly, one coeliac family included four, six families three and 17 families two affected members in addition to the index case.

The affliction rates in the siblings, parents and children were similar in both patient series. Siblings had the highest disease frequency, 6.9% in the dermatitis herpetiformis and 6.7% in the coeliac disease series, and the children the lowest, 3.9% in the dermatitis herpetiformis and 3.3% in the coeliac disease series (I; Table VI).

Concordance of dermatitis herpetiformis and coeliac disease in monozygous twins (II)

Based on the eight microsatellite markers, the probability of any of the apparently monozygous twin pairs being dizygous was $0.25^8=0.000015$, thus monozygosity could be assumed. The frequency of monozygous twins in the present dermatitis herpetiformis series was 6/1292, i.e. 0.005. This is equal to that reported in many populations, i.e., approximately 0.004 (Vogel & Moltulsky, 1997).

Five of the six monozygous twin pairs were concordant for gluten-sensitive disease (Figure 2), which gives a casewise concordance rate of 0.91. Three twins were concordant for dermatitis herpetiformis and in two pairs one twin had dermatitis herpetiformis and the other coeliac disease. The discordance was confirmed in the sixth twin pair by a repeated negative small-intestinal and skin immunofluorescence biopsy. The follow-up period for the twins varied from three to 32 years, and it is of note that the discordant pair had the shortest follow-up time. Five of the twins had the HLA DR3-DQ2 haplotype and the remaining pair the DR4-DQ8 haplotype (Figure 2). Unlike the other twin pairs, the discordant twins showed no homozygosity in any HLA risk loci.

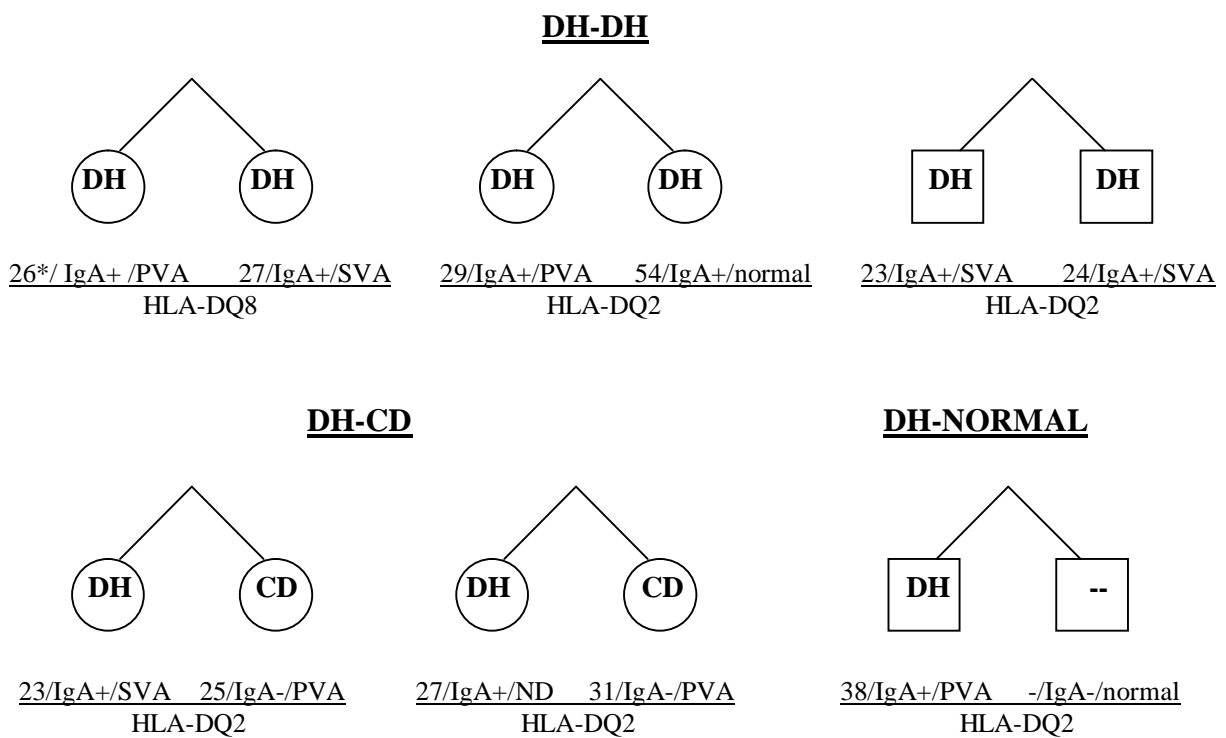

Figure 2. Clinical data, skin and small-intestinal biopsy findings and HLA status of six monozygous twins

*Age at diagnosis

DH=dermatitis herpetiformis

CD=coeliac disease

IgA+/-=Immunoglobulin A deposits found/not found in the papillary dermis

PVA=partial villous atrophy

SVA=subtotal villous atrophy

Type 1 diabetes in dermatitis herpetiformis (III)

Of the 1104 patients with dermatitis herpetiformis, 25 (2.3%) had associated type 1 diabetes. Type 1 diabetes was diagnosed before dermatitis herpetiformis in all except one case. The mean age at the diagnosis of diabetes was 14.8 (range 1-40) years and that of dermatitis herpetiformis 32.2 (range 17-56) years. Jejunal biopsy showed villous atrophy in 19 (76%) of the dermatitis herpetiformis patients with type 1 diabetes and in 37 (74%) of the dermatitis herpetiformis case controls.

Seventeen (1.3%) of the first-degree relatives of the patients with isolated dermatitis herpetiformis were affected by type 1 diabetes. The frequency was 3.0% (three relatives) in the first-degree relatives of the dermatitis herpetiformis patients with type 1 diabetes, which is a non-significant ($p=0.17$; chi-squared test) difference. In one dermatitis herpetiformis family, the relatives were affected by dermatitis herpetiformis, coeliac disease and type 1 diabetes in three consecutive generations (Figure 3).

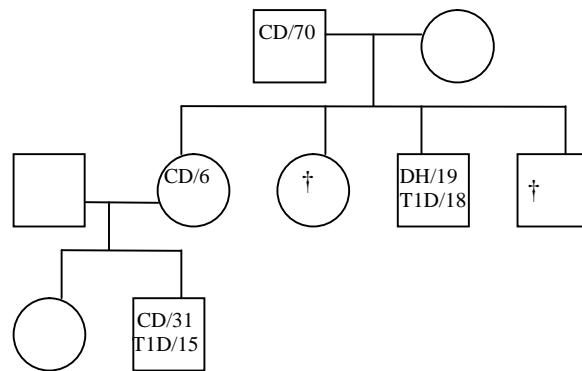

Figure 3. Occurrence of dermatitis herpetiformis (DH), type 1 diabetes (T1D) and coeliac disease (CD) in three generations in one family. Numbers indicate the age at diagnosis of the respective disease, † indicates death.

All 25 dermatitis herpetiformis patients with type 1 diabetes and 50 case controls adhered to a gluten-free diet after diagnosis. Twenty-two (88%) of these patients with type 1 diabetes and 47 (94%) of the controls followed the diet strictly. Overall, the response to the diet was good or moderate in 84% and 94% of the patients, respectively. Twenty-one (84%) and 42 (84%) of the controls received additional treatment with dapsone. The proportion of the patients who could stop the use of dapsone or reduce the dose by more than 50% was similar in both groups (Table 7).

Table 7. Response to a gluten-free diet (GFD) in patients with dermatitis herpetiformis (DH) and associated type 1 diabetes (T1D) and in control DH patients receiving dapsone.

	<u>Patients with DH+T1D</u> (n=21)			<u>Case controls</u> (n=42)		
	Good	Moderate	No response	Good	Moderate	No response
Response to a GFD						
Number of patients (%)	12 (57%)	5 (24%)	4 (19%)	25 (60%)	11 (26%)	6 (14%)
Initial dose of dapsone, mg/day (range)	45 (100-25)	88 (150-50)	70 (200-25)	50 (200-25)	77 (200-25)	80 (200-25)
Time needed for a response; years (range)	3.7 (0.5-9)	5.3 (0.5-9)	-	2.7 (0.5-11)	4.5 (1-7)	-

Lymphoma in dermatitis herpetiformis (IV)

Lymphoma in dermatitis herpetiformis patients and their first-degree relatives

Twelve (1.1%) of the 1104 patients with dermatitis herpetiformis contracted lymphoma during the study (Table 8).

Table 8. Dermatitis herpetiformis (DH) and associated lymphomas collected in Helsinki University Central Hospital and Tampere University Hospital in 1969-2000.

Year of DH-diagnosis	Patients with DH	Observed lymphoma
<1971	34	0
1971-75	161	1
1976-80	241	3
1981-85	228	1
1986-90	201	0
1991-95	147	2
1996-2000	92	3
2001-2003	-	2
All	1104	12

Original biopsy specimens were available for re-examination from 11 patients. One lymphoma occurring in the colon and initially classified as a histiocytic lymphoma/immunoblastic sarcoma was re-classified as an anaplastic carcinoma due to positive epithelial cell marker (panCK and EMA) and negative T-cell (CD3, CD5) and B-cell (CD20) marker stainings. Eight of the lymphomas were B-cell (6 diffuse large cell, 2 follicular) and two T-cell (both EATL) type. One remained unclassified due to missing material.

The lymphomas were found to develop 2-31 years after the diagnosis of dermatitis herpetiformis (Table 9). At the diagnosis of lymphoma the mean age of the patients was 55 years (range 32-79 years). Seven of the patients died (median 1, range 0-16 years) after the diagnosis of lymphoma (IV; Table 1).

Three (0.2%) of the 1825 first-degree relatives contracted lymphoma but none of them were known to have dermatitis herpetiformis or coeliac disease. Two lymphomas were diffuse large B-cell lymphoma (one in the jejunum, the other in a cervical node), and one was a mantle-cell lymphoma in the stomach. The age at the diagnosis of lymphoma was 56, 59 and 59 years, respectively. All three relatives had died from 0 to three years after the diagnosis of lymphoma.

Table 9. Time from diagnosis of dermatitis herpetiformis (DH) to the appearance and site of lymphoma and survival of 10 patients with T- or B-cell lymphomas

	T-cell lymphoma (n=2)	B-cell lymphoma (n= 8)
Time in years; median (range)	4.5 (3-6)	18 (2-31)
Site in gut or mesenterium; n	2	3
Death from lymphoma; n (survival in years)	1 (<1)	5 (3*, range 0-16)

*Median

Gluten-free diet and lymphoma

Eight (73%) patients with dermatitis herpetiformis and lymphoma had not followed a strict gluten-free diet during the preceding five years before the appearance of lymphoma. Overall, the 11 dermatitis herpetiformis patients with lymphoma had adhered to a gluten-free diet for significantly fewer months ($p=0.041$) than their case controls without lymphoma (IV, Table 2).

Small-intestinal biopsy was retaken in six dermatitis herpetiformis patients with lymphoma 0-9 years before the lymphoma appeared, and four of them still showed villous atrophy. Two of these patients (IV; Table 1, patients 6 and 10) had not adhered to a gluten-free diet at all. The other two (patients 2 and 11) had adhered strictly to a gluten-free diet though they still needed dapsone to control the rash. One patient with lymphoma (patient 7) for whom no control biopsy was performed assured strict adherence to a gluten-free diet for five years though he continuously needed dapsone to control the rash.

DISCUSSION

Dermatitis herpetiformis and coeliac disease in first-degree relatives and monozygous twins

The present study showed that nearly a fifth of patients with dermatitis herpetiformis had affected first-degree relatives, and that the combined prevalence of dermatitis herpetiformis and coeliac disease among the first-degree relatives was 5.4%. Moreover, the combined incidence among the first-degree relatives was 15 times higher than the annual incidence for people living in Tampere (Collin et al. 1997). The familial clustering of dermatitis herpetiformis has previously not been well recognised whereas that of coeliac disease is well known (Cooke & Holmes 1984). Meyer & Zone (1987) reported from Utah, USA, that six (0.8%) of the 740 first-degree relatives of patients with dermatitis herpetiformis were affected by the disease, but they did not give any data on coeliac disease among the relatives. Reunala (1996) reported that 10.5% of the 999 Finnish patients with dermatitis herpetiformis had an affected first-degree relative either with dermatitis herpetiformis or coeliac disease, but no prevalence rates were given for the relatives.

In the present study, similarly to the patients with dermatitis herpetiformis, 19% of the patients with coeliac disease had affected first-degree relatives. The combined prevalence of the two diseases among the first-degree relatives, 5.5%, was the same as among the first-degree relatives of the dermatitis herpetiformis patients. The prevalence of dermatitis herpetiformis was higher among the relatives of patients with dermatitis herpetiformis than among the relatives of patients with coeliac disease, but this difference was not statistically significant. This difference might be due to the fact that the rash of dermatitis herpetiformis is more easily recognized than the variable gastrointestinal symptoms of coeliac disease by the relatives of patients with dermatitis herpetiformis.

The response rate to the questionnaire was 86% among the patients with dermatitis herpetiformis but only 54% in the coeliac patients. The high response rate in the patients with dermatitis herpetiformis seems to be due to the fact that these patients were followed up, mostly by the same dermatologist, for longer periods than those with coeliac disease.

The present 5.4% and 5.5% prevalences in relatives are rather similar to the 4.5%, 5.6% and 8.3% prevalence rates found recently by serological screening of the first-degree relatives of patients with coeliac disease (Petaros et al. 2002, Fasano et al. 2003, Högberg et al. 2003). The reasonably high prevalence rates in the present study, where no systematic serological screening was performed, might be due to the fact that the patients were well informed about the familial nature of dermatitis herpetiformis and coeliac disease. This explanation is, however, not supported by the recent studies in which a high rate of undiagnosed coeliac disease was detected by serological screening among the members of multiple-case coeliac disease families despite awareness of the clinical symptoms of the disorder (Mustalahti et al. 2002, Gudjonsdottir 2004). In the present study, several multiple-case families were identified both in the dermatitis herpetiformis and coeliac disease series. Serological screening of coeliac disease in these families would probably have detected even more affected relatives. There may also be a few first-degree relatives with undiagnosed dermatitis herpetiformis with mild symptoms. However, the possibility that there could be asymptomatic relatives with undetected dermatitis herpetiformis (i.e. “subclinical dermatitis herpetiformis”) is unlikely because earlier studies with skin biopsies from asymptomatic relatives (Reunala 1976, Leonard et al. 1983) have failed to reveal IgA-deposits in them.

The present series of six monozygous twins is the largest reported series of twins affected with both dermatitis herpetiformis and coeliac disease. In these twins the casewise concordance rate was 0.91. This is a high concordance rate for a multifactorial disease since the concordance rates reported in many complex diseases, such as type 1 diabetes, have generally been much lower (Salvetti et al. 2000). This indicates a high impact of genetic factors in the pathogenesis of dermatitis herpetiformis and coeliac disease.

As the only discordant twin pair had the shortest follow-up of only three years, it is possible that also this pair will turn out to be concordant in the long run. Supporting such a possibility, one of the present twins contracted dermatitis herpetiformis 25 years later than her twin pair. Similarly, Bardella et al. (2000) reported a monozygous twin who developed coeliac disease 10 years later than her twin sister.

The twins in the present study derived from a prospectively collected series of 1292 patients with dermatitis herpetiformis but not from a population-based twin registry, which would be the ideal study material. Recently, Greco et al. (2002) reported a casewise concordance rate of 0.86 in 20

monozygous twin pairs with coeliac disease in a population-based Italian twin registry study. This rate is almost the same as the present 0.91, confirming that a very high concordance rate is typical for monozygous twins with either coeliac disease or dermatitis herpetiformis.

Type 1 diabetes in dermatitis herpetiformis

In a previous study consisting of 305 patients with dermatitis herpetiformis from the Tampere series, the prevalence of type 1 diabetes was low, i.e. 1%, when compared to 5.5% in the patients with coeliac disease (Collin et al. 1994, Reunala & Collin 1997). In the present larger series of 1104 dermatitis herpetiformis patients from Helsinki and Tampere, the prevalence of type 1 diabetes was 2.3%. This is three times higher than the 0.7% prevalence of type 1 diabetes in the adolescent population in Finland (Tuomilehto et al. 1999). The 2.3% prevalence of type 1 diabetes in the present patients with dermatitis herpetiformis was, however, still significantly ($p=0.003$) lower than the 5.4% prevalence previously found in patients with coeliac disease in Tampere (Collin et al. 1994). The markedly lower prevalence of type 1 diabetes in dermatitis herpetiformis than in coeliac disease may be explained by the much earlier onset of type 1 diabetes than that of dermatitis herpetiformis. In contrast to dermatitis herpetiformis, coeliac disease also seems to have its onset frequently in childhood or adolescence. In children it seems to develop soon after the diagnosis of diabetes (Saukkonen et al. 1996, Mäki et al. 2003). Furthermore, awareness of the frequent occurrence of subclinical coeliac disease in the general population and especially in patients with type 1 diabetes has led to an increasing use of serological screening tests (Collin et al. 1989, Cronin & Shanahan 1997, Holmes 2002). The explanation that the serological screening now performed frequently in patients with type 1 diabetes often leads to early diagnosis of subclinical coeliac disease seems valid. Due to this the number of type 1 diabetes patients who contract dermatitis herpetiformis at a later age could be rather low. In our patient population this has resulted in a continuously increasing incidence of coeliac disease, whereas the incidence of dermatitis herpetiformis has remained at the same level (Collin et al. 1997).

The prevalence of type 1 diabetes in the present study was 1.3% among the first-degree relatives of patients with dermatitis herpetiformis and as high as 3% in the relatives of patients with dermatitis herpetiformis and associated type 1 diabetes. Recently, the first-degree relatives of patients with coeliac disease were also reported to have the same 1.3% prevalence of type 1 diabetes (Cataldo &

Marino, 2003). The most likely reason for the increased prevalence of type 1 diabetes among the first-degree relatives is the segregation of HLA-associated risk genes among them (Mäki et al. 1991b). In the present study, no HLA typing was performed, but it is well documented that approximately 90% of patients with coeliac disease or dermatitis herpetiformis carry the HLA DR3-DQ2 haplotype, and most of the remaining patients have HLA DR4-DQ8 (Sollid et al.1989, Spurkland et al.1997). These haplotypes are also strongly associated with type 1 diabetes (Ide & Eisenbarth 2003). In an earlier study which included 18 of the present dermatitis herpetiformis patients with type 1 diabetes it was shown that the patients had different combinations of HLA risk alleles of coeliac disease and type 1 diabetes or one risk allele alone (Reijonen et al. 1991). It seems evident that the first-degree relatives carrying these risk alleles may then contract type 1 diabetes, coeliac disease, dermatitis herpetiformis and sometimes also two disorders together. The main environmental factor contributing to the pathogenesis of coeliac disease and dermatitis herpetiformis is wheat gluten. An additional triggering factor may be viral infection, which has also an important role in the pathogenesis of type 1 diabetes (Kagnoff et al. 1987, Lähdeaho et al. 1993, Haverkos et al. 2003).

The fact that about 25% of all patients with dermatitis herpetiformis and also those with associated type 1 diabetes have normal villous morphology and negative serology for gluten-sensitive enteropathy is of clinical importance (Collin & Reunala 2003). Physicians treating patients with type 1 diabetes should recognize also the rash of dermatitis herpetiformis, which then can be treated effectively with a gluten-free diet as shown in the present study population.

Gluten-free diet controls in dermatitis herpetiformis both the rash and the enteropathy and reduces the risk of lymphoma (Garioch et al. 1994, Lewis et al. 1996, Sategna-Giudetti et al. 2000). Furthermore, the dietary treatment allows tapering off or withdrawal of dapsone, which can have many harmful side-effects (Wolf et al. 2000). Dermatitis herpetiformis and coeliac disease patients with type 1 diabetes have to maintain a combination of a gluten-free diet and a diet recommended for type 1 diabetes. Combining these two different diets may not be easy, as shown by previous studies in which only about 50% of coeliac disease patients with type 1 diabetes adhered strictly to a gluten-free diet (Walsh et al. 1978, Kaukinen et al. 1999b). In contrast, the majority of the present dermatitis herpetiformis patients with type 1 diabetes could adhere strictly to the gluten-free diet. They also responded to the diet as well as the patients having only dermatitis herpetiformis. One

explanation for the better compliance in the dermatitis herpetiformis patients in the present study could be the harmful, itchy rash, which easily relapses in the event of dietary faults.

Lymphoma in dermatitis herpetiformis

Lymphoma is a well-known complication in coeliac disease and dermatitis herpetiformis. The first study in dermatitis herpetiformis found a relative risk of 100 (Leonard et al. 1983b). Thereafter, the relative risks for lymphoma have been clearly lower, from 10.3 to 1.9 (Table 4). In the present study, in 1104 patients with dermatitis herpetiformis collected during 30 years, the frequency of lymphoma was 1%. This is comparable to the frequencies of 0.5-2.8% previously reported in studies on patients with dermatitis herpetiformis (Table 4). Recent studies in patients with coeliac disease have found more variable lymphoma frequencies. In Sweden the frequency was 0.4% (Askling et al. 2002), in the US 2.4% (Green et al. 2003) and in Canada 8.4% (Freeman 2004). One explanation for the higher lymphoma frequencies in the US and Canadian coeliac disease series than in the present patients with dermatitis herpetiformis could be differences in the adherence to a gluten-free diet. The number of patients on a diet was not given in the Swedish, US or Canadian lymphoma studies, whereas most of the patients in the present series were known to adhere well to a gluten-free diet (Collin et al. 1996).

In the present study, three (0.2%) of the 1825 first-degree relatives of patients with dermatitis herpetiformis had contracted lymphoma, all had died and the point prevalence was thus 0%. The prevalence of non-Hodgkin's lymphoma in the general population in Finland is 0.1% (Finnish Cancer Registry 2004). This shows that the risk of lymphoma seems not to be increased among the first-degree relatives of patients with dermatitis herpetiformis though they frequently contract coeliac disease or dermatitis herpetiformis. That the frequency of lymphoma seems not to be increased in the first-degree relatives of the patients with dermatitis herpetiformis is supported by a recent study which found no excess mortality in the relatives of patients with coeliac disease (Corrao et al. 2001). It should be noted, however, that the frequency of lymphomas recorded in the present first-degree relatives is a minimum figure because it was obtained by a questionnaire and not by a search of the Finnish Cancer Registry.

In the present study, most of the lymphomas in the patients with dermatitis herpetiformis were of B-cell type, although EATL has been considered to be the predominant type in coeliac disease (Isaacson et al. 1985, Egan et al. 1995). The present finding is in line with a Swedish study in which five out of 13 lymphomas in patients with dermatitis herpetiformis were of B-cell type (Sigurgeirsson et al. 1994). Similarly, recent studies in patients with coeliac disease have also reported a high proportion of B-cell lymphomas (Askling et al. 2002, Catassi et al. 2002, Green et al. 2003). These findings show that in addition to EATL, patients with dermatitis herpetiformis and coeliac disease possibly carry also an increased risk for B-cell lymphomas. In patients with dermatitis herpetiformis these B-cell lymphomas can be present in the gastrointestinal tract or elsewhere and develop a few or several years after the diagnosis of dermatitis herpetiformis.

A strict gluten-free diet for more than five years has been reported to give protection against the development of lymphoma in coeliac disease and dermatitis herpetiformis (Holmes et al. 1989, Lewis et al. 1996). Supporting this, eight (73%) of the present dermatitis herpetiformis patients with lymphoma had not been on a strict gluten-free diet for five years before the appearance of lymphoma. Furthermore, the dermatitis herpetiformis patients with lymphoma had adhered to a strict gluten-free diet for significantly fewer months than the dermatitis herpetiformis controls without lymphoma. A recent study in patients with coeliac disease in the USA has questioned the protective effect of a gluten-free diet (Green et al. 2003). However, in that study lymphomas appeared rather soon, i.e. median of three years, after the diagnosis of dermatitis herpetiformis. This time period on a gluten-free diet may not be sufficient to give protection against lymphoma, because previous European studies (Holmes et al. 1989, Lewis et al. 1996) documented the protective effect first after five years on a gluten-free diet.

CONCLUSIONS AND FUTURE ASPECTS

The present study documented a combined 5.4% prevalence of dermatitis herpetiformis and coeliac disease among the first-degree relatives of patients with dermatitis herpetiformis (I). A similar high prevalence was found among the relatives of patients with coeliac disease. In the six monozygous twins the casewise concordance rate of dermatitis herpetiformis or dermatitis herpetiformis and coeliac disease was 0.91 (II). The present study also showed that the prevalence of type 1 diabetes was threefold in the patients with dermatitis herpetiformis and twofold in their first-degree relatives compared to that in the adolescent population of Finland (III). Eleven (1%) of the 1104 patients with dermatitis herpetiformis contracted non-Hodgkin's lymphoma, but among the first-degree relatives the frequency (0.2%) seemed not to be increased (IV).

The frequent occurrence of dermatitis herpetiformis and coeliac disease among the first-degree relatives of patients with dermatitis herpetiformis in the present study demonstrates that screening for coeliac disease is warranted also in this high risk group, as it has been recommended for first-degree relatives of patients with coeliac disease (Corazza & Gasbarrini 1995, Working group appointed by the Finnish Society of Gastroenterology 1999). The observed association of dermatitis herpetiformis and type 1 diabetes calls for physicians treating patients with type 1 diabetes to recognize the symptoms and signs of dermatitis herpetiformis, especially because a quarter of patients with dermatitis herpetiformis are known to present with negative serology (Collin & Reunala 2003).

A gluten-free diet is the treatment of choice for dermatitis herpetiformis though patients can also control the rash with dapsone only. Adherence to a gluten-free diet heals both the rash and the enteropathy and, as in coeliac disease, dietary treatment seems to diminish the risk of lymphoma (Holmes et al. 1989, Lewis et al. 1996). This study demonstrated that patients with concomitant dermatitis herpetiformis and type 1 diabetes can adhere and respond to a gluten-free diet similarly to patients with dermatitis herpetiformis alone. Therefore, a gluten-free diet should be recommended to these patients as well as to patients with isolated dermatitis herpetiformis.

The present study gave further support to the protective effect of a strict gluten-free diet against the development of lymphoma in patients with dermatitis herpetiformis. Due to the increased risk for lymphoma linked to insufficient adherence to dietary treatment, the possibility of this rare but serious

complication should especially be kept in mind in patients with dermatitis herpetiformis who continuously fail to adhere to a gluten-free diet or revert later to a normal diet.

The lymphomas observed in the present study were, in addition to EATL, frequently also B-cell lymphomas arising within and outside the gastrointestinal tract. Whether the development of extraintestinal B-cell lymphomas is related to gluten sensitivity and activation of the immune system in the gut or elsewhere needs to be studied. Osteoporosis is a further documented consequence of coeliac disease (Valdimarsson et al. 1994, Walters 1994). A long-term follow-up of osteoporosis and its consequences in patients with dermatitis herpetiformis adhering strictly to a gluten-free diet is also warranted.

The prevalence rates observed in the present patients with dermatitis herpetiformis and their first-degree relatives are not maximum figures though the patient series was prospectively collected during 30 years and a subgroup was questioned about the affected first-degree relatives after a mean follow up of 15 years. Only after surveillance for whole life, maximum prevalences of type 1 diabetes and lymphoma would be reached. Similarly, longer follow-up with additional serological screening of subclinical coeliac disease would give the lifetime prevalence of coeliac disease and dermatitis herpetiformis among the first-degree relatives. Due to this, the present dermatitis herpetiformis patient series is being further followed up and the occurrence of malignancies and especially of lymphoma will be estimated from data of the Finnish Cancer Registry, and survival from the death registry.

It is of interest that the present first-degree relatives of patients with dermatitis herpetiformis and of those with coeliac disease were similarly affected by both dermatitis herpetiformis and coeliac disease. Such a mixed presentation of both diseases in the same families has seldom been reported (Reunala et al. 1996, Korponay-Szabo et al. 1998). In both patient series, the prevalence of coeliac disease among relatives was higher than that of dermatitis herpetiformis. Similar segregation patterns observed in the families further support the hypothesis that dermatitis herpetiformis is an extraintestinal manifestation of coeliac disease. Moreover, the present and previous (Jepson & Ullman 1980, Kosnai et al. 1985) monozygous twins with one having dermatitis herpetiformis and the other coeliac disease show that no extra genes are needed for the development of dermatitis herpetiformis. All knowledge so far suggests that dermatitis herpetiformis is a cutaneous phenotype of coeliac disease (Reunala 1998, Fry 2002, Karpati 2004). Though a strict gluten-free diet heals the

rash in dermatitis herpetiformis, further studies are needed to confirm whether epidermal transglutaminase is the antigen for pathognomonic IgA deposition in the skin (Sardy et al. 2002, Biagi et al. 2003). In addition, research should be focused on the environmental factors which could trigger the development of dermatitis herpetiformis from a mainly subclinical mode of presentation and possibly also from latent coeliac disease both in the families of patients with dermatitis herpetiformis and coeliac disease.

ACKNOWLEDGEMENTS

The present study was carried out at the Department of Dermatology and Venereology, Tampere University Hospital, the Medical School of the University of Tampere and the National Graduate School of Clinical Investigation.

First I want to express my deepest gratitude to my supervisors Professor Timo Reunala, MD, and Docent Pekka Collin, MD. Without their help the present study would never have been done. Professor Reunala first aroused my interest in dermatitis herpetiformis, then offered me this excellent patient material and finally guided me patiently during the years of this study. His huge energy and enthusiasm have been of importance and supported me in carrying on through moments of doubt. Docent Pekka Collin has been the expert in the field of internal medicine, and he has always patiently advised me in this area. I am also grateful for his perceptive comments and constructive criticism – often asked for and also given with a tight schedule.

I wish to thank the external reviewers of this thesis, Professor Ilkka Harvima, MD and Docent Risto Julkunen, MD for their valuable advice and criticism. They have done a thorough job and helped to further improve the manuscript.

I am also grateful to the Heads of the Department of Dermatology, Professor Timo Reunala, again, and Docent Annikki Vaalasti, MD, for offering the opportunity to perform this study and also for their encouraging attitude to this research. Special thanks are due to Docent Vaalasti for always being very flexible and supporting us young colleagues.

I wish to offer my deep thanks to Docent Jukka Partanen, Ph.D. and Kati Karell, Ph.D. in the Tissue Typing Department of the Finnish Red Cross Blood Transfusion Service, who have kindly helped me in the field of the genetics of coeliac disease and dermatitis herpetiformis.

I express my sincere thanks also to my co-authors Mervi Viljamaa, MD, Docent Katri Kaukinen, MD, Professor Mikael Knip, MD, Martine Vornanen, MD, and Hannu Kautiainen M.Sc, for their valuable help. I have been fortunate to have these skilled co-workers who have kindly shared much of their time and knowledge with me.

I would also like to thank Sevastiana Ruusamo, MA, for revision of the English manuscript and Juha Mäkelä for kind assistance in data processing and using the computer.

I am also grateful to all my colleagues at the Department of Dermatology, Tampere University Hospital. They have supported me and always been interested in my studies. The atmosphere in the clinic has been warm and cosy thanks to them.

I am also indebted to Rajja Salminen and Kaisa Kaulio, secretaries at the Department of Dermatology, Tampere University Hospital, for their kind help in some of the paperwork this study has required.

I wish to offer my warm thanks to all the patients kindly participating in this study. Without their involvement this study could never have taken place.

I also thank all my friends for their friendship and support during this study. All the “girls’ evenings” and “sandbox discussions” have reminded me about other important and interesting aspects of life. Especially I want to thank my friend Katja Marnela, MD, who has regularly brought me out of my “research chamber” to have a cup of coffee or lunch together with an interesting discussion outside the field of my research.

Finally, I want to say that I have been privileged to have a wonderful loving family beside me during the years of this study. I want to thank my husband Petteri, who has always loved and supported me, even during the latest hard and busy months. I am deeply grateful for the existence of my lovely sons Aarne and Eero, who have kept me in touch with “real life” during these years of too much work. I also wish to give my warm thanks to my parents for their love and support.

This study was financially supported by National Graduate School of Clinical Investigation, the Medical Research Fund of Tampere University Hospital, the Finnish Dermatological Society and the Finnish Coeliac Society.

Tampere, August 2004

Kaisa Hervonen

REFERENCES

Aine L (1996): Coeliac-type permanent-tooth enamel defects. *Ann Med* 28:9-12.

Airola K, Reunala T, Salo S and Saarialho-Kere UK (1997): Urokinase plasminogen activator is expressed by basal keratinocytes before interstitial collagenase, stromelysin-1, and laminin-5 in experimentally induced dermatitis herpetiformis lesions. *J Invest Dermatol* 108:7-11.

Alexander JO'D (1975): *Dermatitis Herpetiformis*. W.B. Saunders Company Ltd, London.

Anstey A, Wilkinson JD and Walshe MM (1991): Dermatitis herpetiformis in monozygous twins - concordance for dermatitis herpetiformis and gluten-sensitive enteropathy. *Clin Exp Dermatol* 16:51-52.

Ashton-Key M, Diss TC, Pan L, Du MQ and Isaacson PG (1997): Molecular analysis of T-cell clonality in ulcerative jejunitis and enteropathy-associated T-cell lymphoma. *Am J Pathol* 151:493-498.

Askling J, Linet M, Gridley G, Halstensen TS, Ekstrom K and Ekblom A (2002): Cancer incidence in a population-based cohort of individuals hospitalized with celiac disease or dermatitis herpetiformis. *Gastroenterology*. 123:1428-1435.

Auricchio S, Mazzacca R, Tosi R, Visakorpi M, Mäki M and Polanco I (1988): Coeliac disease as a familial condition: Identification of asymptomatic coeliac patients within family groups. *Gastroenterol Int* 1:25-31.

Baker PG, Barry RE and Read AE (1975): Detection of continuing gluten ingestion in treated coeliac patients. *BMJ*:486-488.

Bardella MT, Fredella C, Prampolini L, Marino R, Conte D and Giunta AM (2000): Gluten sensitivity in monozygous twins: a long-term follow-up of five pairs. *Am J Gastroenterol* 95:1503-1505.

Bardella MT, Fredella C, Trovato C, Ermacora E, Cavalli R, Saladino V and Prampolini L (2003): Long-term remission in patients with dermatitis herpetiformis on a normal diet. *Br J Dermatol* 149:968-971.

Biagi F, Bassi E, Ardigo M, Vignini MA, Caravaggi M, Borroni G and Corazza GR (2003): In patients with dermatitis herpetiformis distribution of transglutaminase in cutaneous tissue does not differ from controls. *Dig Liver Dis* 35:41-45.

Bonamico M, Tiberti C, Picarelli A, Mariani P, Rossi D, Cipolletta E, Greco M, Tola MD, Sabbatella L, Carabba B, Magliocca FM, Strisciuglio P and Di Mario U (2001): Radioimmunoassay to detect antitransglutaminase autoantibodies is the most sensitive and specific screening method for celiac disease. *Am J Gastroenterol* 96:1536-1540.

Bottaro G, Cataldo F, Rotolo N, Spina M and Corazza GR (1999): The clinical pattern of subclinical/silent celiac disease: an analysis on 1026 consecutive cases. *Am J Gastroenterol* 94:691-696.

- Buzzetti R, Quattrocchi CC and Nistico L (1998): Dissecting the genetics of type 1 diabetes: relevance for familial clustering and differences in incidence. *Diabetes Metab Rev* 14:111-128.
- Caproni M, Feliciani C, Fuligni A, Salvatore E, Atani L, Bianchi B, Pour SM, Proietto G, Toto P, Coscione G, Amerio P and Fabbri P (1998): Th2-like cytokine activity in dermatitis herpetiformis. *Br J Dermatol* 138:242-247.
- Carbonnel F, Grollet-Bioul L, Brouet JC, Teilhac MF, Cosnes J, Angonin R, Deschaseaux M, Chatelet FP, Gendre JP and Sigaux F (1998): Are complicated forms of celiac disease cryptic T-cell lymphomas? *Blood* 92:3879-3886.
- Carroccio A, Vitale G, Di Prima L, Chifari N, Napoli S, La Russa C, Gulotta G, Averna MR, Montalto G, Mansueto S and Notarbartolo A (2002). Comparison of anti-transglutaminase ELISAs and an anti-endomysial antibody assay in the diagnosis of celiac disease: a prospective study. *Clin Chem* 48:1546-1550.
- Castellino F, Scaglione N, Grosso SB, and Sategna-Guidetti C (2000): A novel method for detecting IgA endomysial antibodies by using human umbilical vein endothelial cells. *Eur J Gastroenterol Hepatol* 12:45-49.
- Cataldo F and Marino V (2003): Increased prevalence of autoimmune diseases in first-degree relatives of patients with celiac disease. *J Pediatr Gastroenterol Nutr* 36:470-473.
- Cataldo F, Marino V, Bottaro G, Greco P and Ventura A (1997): Coeliac disease and selective immunoglobulin A deficiency. *J Pediatr* 131:306-308.
- Catassi C, Fabiani E, Ratsch IM, Coppa GV, Giorgi PL, Pierdomenico R, Alessandrini S, Iwanejko G, Domenici R, Mei E, Miano A, Marani M, Bottaro G, Spina M, Dotti M, Montanelli A, Barbato M, Viola F, Lazzari R, Vallini M, Guariso G, Plebani M, Cataldo F, Traverso G and Ventura A (1996): The coeliac iceberg in Italy. A multicentre antigliadin antibodies screening for coeliac disease in school-age subjects. *Acta Paediatr Suppl* 412:29-35.
- Catassi C, Fabiani E, Corrao G, Barbato M, De Renzo A, Carella AM, Gabrielli A, Leoni P, Carroccio A, Baldassarre M, Baldassarre M, Bertolani P, Caramaschi P, Sozzi M, Guariso G, Volta, U and Corazza, GR. Italian Working Group on Coeliac Disease and Non-Hodgkin's-Lymphoma (2002). Risk of non-Hodgkin lymphoma in celiac disease. *JAMA* 287:1413-1419.
- Cellier C, Delabesse E, Helmer C, Patey N, Matuchansky C, Jabri B, Macintyre E, Cerf-Bensussan N and Brousse N (2000): Refractory sprue, coeliac disease, and enteropathy-associated T-cell lymphoma. French Coeliac Disease Study Group. *Lancet* 356: 203-208.
- Chan KN, Phillips AD, Walker-Smith JA, Koskimies S and Spencer J (1993): Density of gamma/delta T cells in small bowel mucosa related to HLA-DQ status without coeliac disease. *Lancet* 342:492-493.
- Chorzelski TP, Sulej J, Tchorzewska H, Jablonska S, Beutner EH and Kumar V (1983): IgA class endomysium antibodies in dermatitis herpetiformis and coeliac disease. *Ann N Y Acad Sci* 420:325-334.
- Christensen OB, Hindsen M and Svensson A (1986): Natural history of dermatitis herpetiformis in southern Sweden. *Dermatologica* 173:271-277.

- Collin P and Mäki M (1994): Associated disorders in coeliac disease: clinical aspects. *Scand J Gastroenterol* 29:769-775.
- Collin P and Reunala T (2003): Recognition and management of the cutaneous manifestations of celiac disease: a guide for dermatologists. *Am J Clin Dermatol* 4:13-20.
- Collin P, Salmi J, Hällström O, Oksa H, Oksala M, Mäki M and Reunala T (1989): High frequency of coeliac disease in adult patients with type-I diabetes. *Scand J Gastroenterol* 24:81-84.
- Collin P, Pirttilä T, Nurmikko T, Somer H, Erilä T and Keyriläinen O (1991): Celiac disease, brain atrophy, and dementia. *Neurology* 41:372-375.
- Collin P, Helin H, Mäki M, Hällström O, Karvonen A-L (1993): Follow-up of patients positive in reticulín and gliadin antibody tests with normal small bowel biopsy findings. *Scand J Gastroenterol* 28:595-598.
- Collin P, Reunala T, Pukkala E, Laippala P, Keyriläinen O and Pasternack A (1994): Coeliac disease-associated disorders and survival. *Gut* 35:1215-1218.
- Collin P, Pukkala E and Reunala T (1996): Malignancy and survival in dermatitis herpetiformis: a comparison with coeliac disease. *Gut* 38:528-530.
- Collin P, Reunala T, Rasmussen M, Kyrönpalo S, Pehkonen E, Laippala P and Mäki M (1997): High incidence and prevalence of adult coeliac disease. Augmented diagnostic approach. *Scand J Gastroenterol* 32:1129-1133.
- Collin P, Kaukinen K, Välimäki M and Salmi J (2002): Endocrinological disorders and celiac disease. *Endocr Rev* 23:464-483.
- Collin P, Thorell L, Kaukinen K and Mäki M (2004): The safe threshold for gluten contamination in gluten-free products. Can trace amounts be accepted in the treatment of coeliac disease? *Aliment Pharmacol Therapy*, in press.
- Congia M, Cucca F, Frau F, Lampis R, Melis L, Clemente MG, Cao A and De Virgiliis S (1994): A gene dosage effect of the DQA1*0501/DQB1*0201 allelic combination influences the clinical heterogeneity of celiac disease. *Hum Immunol* 40:138-42
- Cooke WT and Holmes GKT (1984): *Coeliac Disease*. Churchill Livingstone, Edinburgh.
- Cooper BT, Holmes GK and Cooke WT (1978): Coeliac disease and immunological disorders. *BMJ* 1:537-539.
- Corazza GR and Gasbarrini G (1995): Coeliac disease in adults. *Baillieres Clin Gastroenterol* 9:329-350.
- Corazza GR, Frazzoni M and Gasbarrini G (1984): Jejunal intraepithelial lymphocytes in coeliac disease: are they increased or decreased? *Gut* 25:158-162.
- Corazza GR, Frisoni M, Treggiari EA, Valentini RA, Filipponi C, Volta U and Gasbarrini G (1993): Subclinical celiac sprue. Increasing occurrence and clues to its diagnosis. *J Clin Gastroenterol* 16:16-21.

- Corazza GR, Andreani ML, Venturo N, Bernardi M, Tosti A and Gasbarrini G (1995): Celiac disease and alopecia areata: report of a new association. *Gastroenterology* 109:1333-1337.
- Corrao G, Corazza GR, Bagnardi V, Brusco G, Ciacci C, Cottone M, Sategna Guidetti C, Usai P, Cesari P, Pelli MA, Loperfido S, Volta U, Calabro A and Certo M (2001): Mortality in patients with coeliac disease and their relatives: a cohort study. *Lancet* 358:356-361.
- Cronin CC and Shanahan F (1997): Insulin-dependent diabetes mellitus and coeliac disease. *Lancet* 349:1096-1097.
- Davison S (2002): Coeliac disease and liver dysfunction. *Arch Dis Child* 87:293-296.
- Dieterich W, Ehnis T, Bauer M, Donner P, Volta U, Riecken EO and Schuppan D (1997): Identification of tissue transglutaminase as the autoantigen of celiac disease. *Nat Med* 3:797-801.
- Dieterich W, Laag E, Schopper H, Volta U, Piecken EO and Schuppan D (1998): Autoantibodies to tissue transglutaminase as predictors for coeliac disease. *Gastroenterology* 115:1317-1321.
- Dieterich W, Laag E, Bruckner-Tuderman L, Reunala T, Karpati S, Zagoni T, Riecken EO and Schuppan D (1999): Antibodies to tissue transglutaminase as serologic markers in patients with dermatitis herpetiformis. *J Invest Dermatol* 113:133-136.
- Egan LJ, Walsh SV, Stevens FM, Connolly CE, Egan EL and McCarthy CF (1995): Celiac-associated lymphoma. A single institution experience of 30 cases in the combination chemotherapy era. *J Clin Gastroenterol* 21:123-129.
- Eliakim R and Sherer DM (2001): Celiac disease: fertility and pregnancy. *Gynecol Obstet Invest* 51:3-7.
- Fabiani E, Catassi C and International Working Group on Eu-tTG (2001): The serum IgA class anti-tissue transglutaminase antibodies in the diagnosis and follow up of coeliac disease. Results of an international multi-centre study. International Working Group on Eu-tTG. *Eur J Gastroenterol Hepatol* 13:659-665.
- Farre C, Humbert P, Vilar P, Varea V, Aldeguer X, Carnicer J, Carballo M and Gassull MA (1999): Serological markers and HLA-DQ2 haplotype among first-degree relatives of celiac patients. Catalanian Coeliac Disease Study Group. *Dig Dis Sci* 44:2344-2349.
- Fasano A, Berti I, Gerarduzzi T, Not T, Colletti RB, Drago S, Elitsur Y, Green PH, Guandalini S and Hill ID (2003): Prevalence of celiac disease in at-risk and not-at-risk groups in the United States: a large multicenter study. *Arch Intern Med* 163:286-292.
- Ferguson A and Murray D (1971): Quantitation of intraepithelial lymphocytes in human jejunum. *Gut* 12(12):988-994.
- Ferguson A, McClure JP and Townley RR (1976): Intraepithelial lymphocyte counts in small intestinal biopsies from children with diarrhoea. *Acta Paediatr Scand* 65:541-546.
- Ferreira M, Davies SL, Butler M, Scott D, Clark M and Kumar P (1992): Endomysial antibody: is it the best screening test for coeliac disease? *Gut* 33:1633-1637.
- Finnish Cancer Registry. Cancer Statistics at www.cancerregistry.fi last updated on 30 Jan 2004.

- Freeman (2004): Lymphoproliferative and intestinal malignancies in 214 patients with biopsy-defined celiac disease. *J Clin Gastroenterol* 38:429-434.
- Fry L (2002): Dermatitis herpetiformis: problems, progress and prospects. *Eur J Dermatol* 12:523-531.
- Fry L, McMinn RM, Cowan JD and Hoffbrand AV (1969): Gluten-free diet and reintroduction of gluten in dermatitis herpetiformis. *Arch Dermatol* 100:129-135.
- Fry L, Seah PP, Riches DJ and Hoffbrand AV (1973): Clearance of skin lesions in dermatitis herpetiformis after gluten withdrawal. *Lancet* 1:288-291.
- Gabrielsen TO and Hoel PS (1985). Primary biliary cirrhosis associated with coeliac disease and dermatitis herpetiformis. *Dermatologica* 170:31-34.
- Gale J, Simmonds PD, Mead GM, Sweetenham JW and Wright DH (2000): Enteropathy-type intestinal T-cell lymphoma: clinical features and treatment of 31 patients in a single center. *J Clin Oncol* 18:795-803.
- Garioch JJ, Lewis HM, Sargent SA, Leonard JN and Fry L (1994): 25 years' experience of a gluten-free diet in the treatment of dermatitis herpetiformis. *Br J Dermatol* 131:541-545.
- Gawkrodger DJ, Blackwell JN, Gilmour HM, Rifkind EA, Heading RC and Barnetson RS (1984): Dermatitis herpetiformis: diagnosis, diet and demography. *Gut* 25:151-157.
- Gobbi G, Bouquet F, Greco L, Lambertini A, Tassinari CA, Ventura A and Zaniboni MG. The Italian Working Group on Coeliac Disease and Epilepsy (1992): Coeliac disease, epilepsy, and cerebral calcifications. *Lancet* 340:439-443.
- Gough KR, Read AE and Naish JM (1962): Intestinal reticulosis as a complication of idiopathic steatorrhoea. *Gut* 3:232-239.
- Graeber M, Baker BS, Garioch JJ, Valdimarsson H, Leonard JN and Fry L (1993): The role of cytokines in the generation of skin lesions in dermatitis herpetiformis. *Br J Dermatol* 129:530-532.
- Greco L, Corazza G, Babron MC, Clot F, Fulchignoni-Lataud MC, Percopo S, Zavattari P, Bouguerra F, Dib C, Tosi R, Troncone R, Ventura A, Mantavoni W, Magazzu G, Gatti R, Lazzari R, Giunta A, Perri F, Iacono G, Cardi E, de Virgiliis S, Cataldo F, De Angelis G, Musumeci S and Clerget-Darpoux F (1998): Genome search in celiac disease. *Am J Hum Genet* 62:669-675.
- Greco L, Romino R, Coto I, Di Cosmo N, Percopo S, Maglio M, Paparo F, Gasperi V, Limongelli MG, Cotichini R, D'Agate C, Tinto N, Sacchetti L, Tosi R and Stazi MA (2002): The first large population based twin study of coeliac disease. *Gut* 50:624-628.
- Green PH, Fleischauer AT, Bhagat G, Goyal R, Jabri B and Neugut AI (2003): Risk of malignancy in patients with celiac disease. *Am J Med* 115:191-195.
- Grefte JM, Bouman JG, Grond J, Jansen W and Kleibeuker JH (1988): Slow and incomplete histological and functional recovery in adult gluten sensitive enteropathy. *J Clin Pathol* 41:886-891.
- Grone E and Nordöy A (1970): Dermatitis herpetiformis, steatorrhoea, and malignancy. *Br Med J* 1:610.

- Gudjonsdottir AH, Nilsson S, Ek J, Kristiansson B and Ascher H (2004): The risk of celiac disease in 107 families with at least two affected siblings. *J Pediatr Gastroenterol Nutr* 38:338-342.
- Hadjivassiliou M, Grunewald RA, Chattopadhyay AK, Davies-Jones GA, Gibson A, Jarratt JA, Kandler RH, Lobo A, Powell T and Smith CM (1998): Clinical, radiological, neurophysiological, and neuropathological characteristics of gluten ataxia. *Lancet* 352:1582-1585.
- Halttunen T and Mäki M (1999): Serum immunoglobulin A from patients with celiac disease inhibits human T84 intestinal crypt epithelial cell differentiation. *Gastroenterology* 116:566-572.
- Hällström O (1989): Comparison of IgA-class reticulin and endomysium antibodies in coeliac disease and dermatitis herpetiformis. *Gut* 30:1225-1232.
- Halstensen TS, Scott H and Brandtzaeg P (1989): Intraepithelial T cells of the TcR gamma/delta+ CD8- and V delta 1/J delta 1+ phenotypes are increased in coeliac disease. *Scand J Immunol* 30:665-672.
- Hardman CM, Garioch JJ, Leonard JN, Thomas HJ, Walker MM, Lortan JE, Lister A and Fry L (1997): Absence of toxicity of oats in patients with dermatitis herpetiformis. *N Engl J Med* 337:1884-1887.
- Haverkos HW, Battula N, Drotman DP and Rennert OM (2003): Enteroviruses and type 1 diabetes mellitus. *Biomed Pharmacother* 57:379-385.
- Henker J, Fischer R and Gebhardt B (1989): Discordant manifestation of celiac disease in monozygous twins. *Klin Padiatr* 201:136-138.
- Högberg L, Falth-Magnusson K, Grodzinsky E and Stenhammar L (2003): Familial prevalence of coeliac disease: a twenty-year follow-up study. *Scand J Gastroenterol* 38:61-65.
- Holmes GK. Screening for coeliac disease in type 1 diabetes (2002): *Arch Dis Child* 87:495-498.
- Holmes GK, Stokes PL, Sorahan TM, Prior P, Waterhouse JA and Cooke WT (1976): Coeliac disease, gluten-free diet, and malignancy. *Gut* 17:612-619.
- Holmes GK, Prior P, Lane MR, Pope D and Allan RN (1989): Malignancy in coeliac disease - effect of a gluten free diet. *Gut* 30:333-338.
- Holopainen P, Mustalahti K, Uimari P, Collin P, Mäki M and Partanen J (2001): Candidate gene regions and genetic heterogeneity in gluten sensitivity. *Gut* 48:696-701.
- Holtmeier W, Rowell DL, Nyberg A and Kagnoff MF (1997): Distinct delta T cell receptor repertoires in monozygotic twins concordant for coeliac disease. *Clin Exp Immunol* 107:148-157.
- Ide A and Eisenbarth GS (2003): Genetic susceptibility in type 1 diabetes and its associated autoimmune disorders. *Rev Endocr Metab* 4:243-253.
- Iltanen S, Holm K, Ashorn M, Ruuska T, Laippala P and Mäki M (1999): Changing jejunal gamma delta T cell receptor (TCR)-bearing intraepithelial lymphocyte density in coeliac disease. *Clin Exp Immunol* 117:51-55.

Ilyas M, Niedobitek G, Agathangelou A, Barry RE, Read AE, Tierney R, Young LS and Rooney N (1995): Non-Hodgkin's lymphoma, coeliac disease, and Epstein-Barr virus: a study of 13 cases of enteropathy-associated T- and B-cell lymphoma. *J Pathol* 177:115-122.

Isaacson PG, O'Connor NT, Spencer J, Bevan DH, Connolly CE, Kirkham N, Pollock DJ, Wainscoat JS, Stein H and Mason DY (1985): Malignant histiocytosis of the intestine: a T-cell lymphoma. *Lancet* 2:688-691.

Ivarsson A, Persson LA, Juto P, Peltonen M, Suhr O and Hernell O (1999): High prevalence of undiagnosed coeliac disease in adults: a Swedish population-based study. *J Intern Med* 245:63-68.

Jaffe ES, Harris NL, Stein H (2001): World Health Organization Classification of Tumours of Hematopoietic and Lymphoid Tissues, Lyon, France, IARC Press, 2001.

Janatuinen EK, Pikkarainen PH, Kempainen TA, Kosma VM, Järvinen RM, Uusitupa MI and Julkunen RJ (1995): A comparison of diets with and without oats in adults with coeliac disease. *N Engl J Med* 333:1033-1037.

Jepsen LV and Ullman S (1980): Dermatitis herpetiformis and gluten-sensitive enteropathy in monozygotic twins. *Acta Derm Venereol* 60:353-5.

Kagnoff MF, Paterson YJ, Kumar PJ, Kasarda DD, Carbone FR, Unsworth DJ and Austin RK (1987): Evidence for the role of a human intestinal adenovirus in the pathogenesis of coeliac disease. *Gut* 28:995-1001.

Karell K, Louka AS, Moodie SJ, Ascher H, Clot F, Greco L, Ciclitira PJ, Sollid LM, Partanen J. European Genetics Cluster on Celiac Disease (2003): HLA types in celiac disease patients not carrying the DQA1*05-DQB1*02 (DQ2) heterodimer: results from the European Genetics Cluster on Celiac Disease. *Hum Immunol* 64:469-477.

Karpati S (2004): Dermatitis herpetiformis: close to unravelling a disease. *J Dermatol Sci* 34:83-90.

Katz SI, Falchuk ZM, Dahl MV, Rogentine GN and Strober W (1972): HL-A8: a genetic link between dermatitis herpetiformis and gluten-sensitive enteropathy. *J Clin Invest* 51:2977-2980.

Kaukinen K, Collin P, Holm K, Rantala I, Vuolteenaho N, Reunala T and Mäki M (1999a): Wheat starch-containing gluten-free flour products in the treatment of coeliac disease and dermatitis herpetiformis. A long-term follow-up study. *Scand J Gastroenterol* 34:163-169.

Kaukinen K, Salmi J, Lahtela J, Siljamäki-Ojansuu U, Koivisto AM, Oksa H and Collin P (1999b): No effect of gluten-free diet on the metabolic control of type 1 diabetes in patients with diabetes and coeliac disease. Retrospective and controlled prospective survey. *Diabetes Care* 22:1747-1748.

Kaukinen K, Turjanmaa K, Mäki M, Partanen J, Venalainen R, Reunala T and Collin P (2000): Intolerance to cereals is not specific for coeliac disease. *Scand J Gastroenterol* 35:942-946.

Kempainen T, Kroger H, Janatuinen E, Arnala I, Kosma VM, Pikkarainen P, Julkunen R, Jurvelin J, Alhava E and Uusitupa M (1999): Osteoporosis in adult patients with coeliac disease. *Bone* 24:249-255.

- Khuffash FA, Barakat MH, Majeed HA, White AG and Beseda AJ (1984): Coeliac disease in monozygotic twin girls. Synchronous presentation. *Gut* 25:1009-1012.
- King AL, Yiannakou JY, Brett PM, Curtis D, Morris MA, Dearlove AM, Rhodes M, Rosen-Bronson S, Mathew C, Ellis HJ and Ciclitira PJ (2000): A genome-wide family-based linkage study of coeliac disease. *Ann Hum Genet* 64:479-490.
- Klein GF, Hintner H, Schuler G and Fritsch P (1983): Junctional blisters in acquired bullous disorders of the dermal-epidermal junction zone: role of the lamina lucida as the mechanical locus minoris resistentiae. *Br J Dermatol* 109:499-508.
- Kolho KL, Farkkila MA and Savilahti E (1998): Undiagnosed coeliac disease is common in Finnish adults. *Scand J Gastroenterol* 33:1280-1283.
- Korbonay-Szabo I, Kovacs J, Lörincz M, Török E and Goracz GY (1998): Families with multiple cases of gluten-sensitive enteropathy. *Z Gastroenterol* 36:553-558.
- Korbonay-Szabo IR, Dahlblom I, Laurila K, Koskinen S, Woolley N, Partanen J, Kovacs JB, Mäki M and Hansson T (2003): Elevation of IgG antibodies against tissue transglutaminase as a diagnostic tool for coeliac disease in selective IgA-deficiency. *Gut* 52:1567-1571.
- Korponay-Szabó IR, Halttunen T, Szalai Z, Laurila K, Király R, Kovács JB, Fésüs L and Mäki M (2004): In vivo targeting of intestinal and extraintestinal transglutaminase 2 by coeliac autoantibodies. *Gut* 53:641-648.
- Kosnai I, Karpati S, Torok E, Bucsky P and Gyodi E (1985): Dermatitis herpetiformis in monozygous twins: discordance for dermatitis herpetiformis and concordance for gluten-sensitive enteropathy. *Eur J Pediatr* 144:404-405.
- Kruizinga E and Hamminga H (1953): Treatment of dermatitis herpetiformis with di-amino-di-phenyl sulphone (DDS). *Dermatologica* 106:387-394.
- Kuitunen P, Kosnai I and Savilahti E (1982): Morphometric study of the jejunal mucosa in various childhood enteropathies with special reference to intraepithelial lymphocytes. *J Pediatr Gastroenterol Nutr* 1:525-531.
- Ladinsler B, Rossipal E and Pittschieler K (1994): Endomysium antibodies in coeliac disease: an improved method. *Gut* 35:776-778
- Lähdeaho ML, Lehtinen M, Rissa HR, Hyöty H, Reunala T and Mäki M (1993): Antipeptide antibodies to adenovirus E1b protein indicate enhanced risk of celiac disease and dermatitis herpetiformis. *Int Arch Allergy Immunol* 101(3):272-6.
- Leon F, Camarero C, R-Pena R, Eiras P, Sanchez L, Baragano M, Lombardia M, Bootello A and Roy G (2001): Anti-transglutaminase IgA ELISA: clinical potential and drawbacks in celiac disease diagnosis. *Scand J Gastroenterol* 36:849-853.
- Leonard JN and Fry L (1991): Treatment and management of dermatitis herpetiformis. *Clin Dermatol* 9:403-408.

- Leonard JN, Haffenden GP, Tucker WF, Unsworth DJ, Sidgwick A, Swain AF and Fry L (1983a): Skin biopsies in relatives of patients with dermatitis herpetiformis. *Acta Derm Venereol* 63:252-254.
- Leonard JN, Tucker WF, Fry JS, Coulter CA, Boylston AW, McMinn RM, Haffenden GP, Swain AF and Fry L (1983b): Increased incidence of malignancy in dermatitis herpetiformis. *Br Med J (Clin Res Ed)*. 286:16-18.
- Lewis HM, Goldin R, Leonard JN (1993). Dermatitis herpetiformis and primary sclerosing cholangitis. *Clin Exp Dermatol* 18:363-5.
- Lewis HM, Reunala TL, Garioch JJ, Leonard JN, Fry JS, Collin P, Evans D and Fry L (1996): Protective effect of gluten-free diet against development of lymphoma in dermatitis herpetiformis. *Br J Dermatol* 135:363-367.
- Logan RF, Rifkind EA, Turner ID and Ferguson A (1989): Mortality in celiac disease. *Gastroenterology* 97:265-271.
- Lohiniemi S, Mäki M, Kaukinen K, Laippala P and Collin P (2000): Gastrointestinal symptoms rating scale in coeliac disease patients on wheat starch-based gluten-free diets. *Scand J Gastroenterol* 35:947-949.
- Lundin KE, Scott H, Hansen T, Paulsen G, Halstensen TS, Fausa O, Thorsby E and Sollid LM (1993): Gliadin-specific, HLA-DQ(alpha 1*0501,beta 1*0201) restricted T cells isolated from the small intestinal mucosa of celiac disease patients. *J Exp Med* 178:187-196.
- MacDonald WC, Dobbins WO 3rd and Rubin CE (1965): Studies of the familial nature of coeliac sprue using biopsy of the small intestine. *N Engl J Med* 272:448-456.
- MacGrecor AJ (2000): Practical approaches to account for bias and confounding in twin data. In: *Advances in Twin and Sib-Pair Analysis*, pp. 35-52. Eds Spector TD, Snieder H, MacGrecor AJ, Greenwich Medical Media Ltd, London.
- Mäki M and Collin P (1997): Coeliac disease. *Lancet* 349:1755-1759.
- Mäki M, Holm K, Collin P and Savilahti E (1991a): Increase in gamma/delta T cell receptor bearing lymphocytes in normal small bowel mucosa in latent coeliac disease. *Scand J Gastroenterol* 32:1412-1414.
- Mäki M, Holm K, Lipsanen V, Hallstrom O, Viander M, Collin P, Savilahti E and Koskimies S (1991b): Serological markers and HLA genes among healthy first-degree relatives of patients with coeliac disease. *Lancet* 338:1350-1353.
- Mäki M, Mustalahti K, Kokkonen J, Kulmala P, Haapalahti M, Karttunen T, Ilonen J, Laurila K, Dahlbom I, Hansson T, Hopfl P and Knip M (2003): Prevalence of celiac disease among children in Finland. *N Engl J Med* 348:2517-2524
- Marks J, Shuster S and Watson AJ (1966): Small-bowel changes in dermatitis herpetiformis. *Lancet* 2:1280-1282.
- Marsh MN (1992): Gluten, major histocompatibility complex, and the small intestine. A molecular and immunobiologic approach to the spectrum of gluten sensitivity ('celiac sprue'). *Gastroenterology* 102:330-354.

- Mayer M, Greco L, Troncone R, Auricchio S and Marsh MN (1991): Compliance of adolescents with coeliac disease with a gluten free diet. *Gut* 32:881-885.
- McMillan SA, Haughton DJ, Biggart JD, Edgar JD, Porter KG and McNeill TA (1991): Predictive value for coeliac disease of antibodies to gliadin, endomysium, and jejunum in patients attending for jejunal biopsy. *BMJ* 303:1163-1165.
- Mearin ML, Biemond I, Pena AS, Vazquez C, Schreuder GT, de Vries RR and van Rood JJ (1983): HLA-DR phenotypes in Spanish coeliac children: their contribution to the understanding of the genetics of the disease. *Gut* 24: 532-537.
- Meyer LJ and Zone JJ (1987): Familial incidence of dermatitis herpetiformis. *J Am Acad Dermatol* 17:643-647.
- Midhagen G, Jarnerot G, Kraaz W (1988): Adult coeliac disease within a defined geographic area in Sweden. A study of prevalence and associated diseases. *Scand J Gastroenterol* 23:1000-1004.
- Mobacken H, Kastrup W and Nilsson LA (1984): Incidence and prevalence of dermatitis herpetiformis in western Sweden. *Acta Derm Venereol* 64:400-404.
- Moi H (1984): Incidence and prevalence of dermatitis herpetiformis in a country in central Sweden, with comments on the course of the disease and IgA deposits as diagnostic criterion. *Acta Derm Venereol* 64:144-150.
- Molberg O, Mcadam SN, Korner R, Quarsten H, Kristiansen C, Madsen L, Fugger L, Scott H, Noren O, Roepstorff P, Lundin KE, Sjoström H and Sollid LM (1998): Tissue transglutaminase selectively modifies gliadin peptides that are recognized by gut-derived T cells in celiac disease. *Nat Med* 4:713-717.
- Murray A, Cuevas EC, Jones DB and Wright DH (1995): Study of the immunohistochemistry and T cell clonality of enteropathy-associated T cell lymphoma. *Am J Pathol* 146:509-519.
- Mustalahti K, Sulkanen S, Holopainen P, Laurila K, Collin P, Partanen J and Mäki M (2002): Coeliac disease among healthy members of multiple case coeliac disease families. *Scand J Gastroenterol* 37:161-165.
- Mylotte M, Egan-Mitchell B, Fottrell PF, McNicholl B and McCarthy CF (1974): Family studies in coeliac disease. *Q J Med* 43:359-369.
- Nielsen OH, Jacobsen O, Pedersen ER, Rasmussen SN, Petri M, Laulund S and Jarnum S (1985): Non-tropical sprue. Malignant diseases and mortality rate. *Scand J Gastroenterol* 20:13-18.
- O'Driscoll BR, Stevens FM, O'Gorman TA, Finnegan P, McWeeney JJ, Little MP, Connolly CE and McCarthy CF (1982): HLA type of patients with coeliac disease and malignancy in the west of Ireland. *Gut* 23:662-665.
- O'Leary C, Walsh CH, Wieneke P, O'Regan P, Buckley B, O'Halloran DJ, Ferriss JB, Quigley EM, Annis P, Shanahan F and Cronin CC (2002): Coeliac disease and autoimmune Addison's disease: a clinical pitfall. *QJM* 95:79-82.
- Parnell N and Ciclitira P (1999): Celiac disease. *Curr Opin Gastroenterol* 15:120-124.

- Peräaho M, Kaukinen K, Paasikivi K, Sievänen H, Lohiniemi S, Mäki M and Collin P (2003): Wheat-starch-based gluten-free products in the treatment of newly detected coeliac disease: prospective and randomized study. *Aliment Pharmacol Ther* 17:587-594.
- Petaros P, Martellosi S, Tommasini A, Torre G, Caradonna M and Ventura A (2002): Prevalence of autoimmune disorders in relatives of patients with celiac disease. *Dig Dis Sci* 47:1427-1431.
- Petronzelli F, Bonamico M, Ferrante P, Grillo R, Mora B, Mariani P, Apollonio I, Gemme G and Mazzilli MC (1997): Genetic contribution of the HLA region to the familial clustering of coeliac disease. *Ann Hum Genet* 61:307-317.
- Ploski R, Ek J, Thorsby E and Sollid LM (1993): On the HLA-DQ(alpha 1*0501, beta 1*0201)-associated susceptibility in celiac disease: a possible gene dosage effect of DQB1*0201. *Tissue Antigens* 41:173-177.
- Polanco I, Mearin ML, Larrauri J, Biemond I, Wipkink-Bakker A and Pena AS (1987): Effect of gluten supplementation in healthy siblings of children with celiac disease. *Gastroenterology* 92:678-681.
- Polvi A, Eland C, Koskimies S, Mäki M and Partanen J (1996): HLA DQ and DP in Finnish families with celiac disease. *Eur J Immunogenet* 23:221-234.
- Polvi A, Arranz E, Fernandez-Arquero M, Collin P, Mäki M, Sanz A, Calvo C, Maluenda C, Westman P, de la Concha EG and Partanen J(1998): HLA-DQ2-negative celiac disease in Finland and Spain. *Hum Immunol* 59:169-175.
- Reif S and Lerner A (2004): Tissue transglutaminase - the key player in celiac disease: a review. *Autoimm Rev* 3:40-45.
- Reijonen H, Ilonen J, Knip M and Reunala T (1991): Insulin-dependent diabetes mellitus associated with dermatitis herpetiformis: evidence for heterogeneity of HLA-associated genes. *Tissue Antigens* 37:94-96.
- Reitamo S, Reunala T, Konttinen YT, Saksela O and Salo OP (1981): Inflammatory cells, IgA, C3, fibrin and fibronectin in skin lesions in dermatitis herpetiformis. *Br J Dermatol* 138:242-247.
- Reunala T (1978): Gluten-free diet in dermatitis herpetiformis. II. Morphological and immunological findings in the skin and small intestine of 12 patients and matched controls. *Br J Dermatol* 98:69-78.
- Reunala T (1996): Incidence of familial dermatitis herpetiformis. *Br J Dermatol* 134:394-398.
- Reunala T (1998): Dermatitis herpetiformis: coeliac disease of the skin. *Ann Med* 30:416-418.
- Reunala T (2001): Dermatitis herpetiformis. *Clin Dermatol* 19:728-736.
- Reunala T and Collin P (1997): Diseases associated with dermatitis herpetiformis. *Br J Dermatol* 136:315-318.
- Reunala T and Lokki J (1978): Dermatitis herpetiformis in Finland. *Acta Derm Venereol* 58:505-510.
- Reunala T, Salo OP, Tiilikainen A, Selroos O and Kuitunen P. Family studies in dermatitis herpetiformis (1976): *Ann Clin Res* 8:254-261.

Reunala T, Blomqvist K, Tarpila S, Halme H and Kangas K (1977): Gluten-free diet in dermatitis herpetiformis. I. Clinical response of skin lesions in 81 patients. *Br J Dermatol* 97:473-480.

Reunala T, Kosnai I, Karpati S, Kuitunen P, Török E and Savilahti E (1984): Dermatitis herpetiformis: jejunal findings and skin response to gluten free diet. *Arch Dis Child* 59:517-522.

Reunala T, Chorzelski TP, Viander M, Sulej J, Vainio E, Kumar V and Beutner EH (1987): IgA anti-endomysial antibodies in dermatitis herpetiformis: correlation with jejunal morphology, gluten-free diet and anti-gliadin antibodies. *Br J Dermatol* 117:185-191.

Reunala T, Collin P, Holm K, Pikkarainen P, Miettinen A, Vuolteenaho N and Mäki M (1998): Tolerance to oats in dermatitis herpetiformis. *Gut* 43:490-493.

Rosner B (1982): A generalization of the paired t test. *Applied Statistics* 31: 9-13.

Salazar de Sousa J, Ramos de Almeida JM, Monteiro MV and Magalhaes Ramalho P. Late onset coeliac disease in the monozygotic twin of a coeliac child. *Acta Paediatr Scand* 76:172-174.

Salvetti M, Ristori G, Bompreszi R, Pozzilli P and Leslie RDG (2000): Twins: mirrors of the immune system. *Immunol Today* 21:342-347.

Sardy M, Karpati S, Peterfy F, Rasky K, Tomsits E, Zagoni T and Horvath A (2000): Comparison of a tissue transglutaminase ELISA with the endomysium antibody test in the diagnosis of gluten-sensitive enteropathy. *Z Gastroenterol* 38:357-364.

Sardy M, Karpati S, Merkl B, Paulsson M and Smyth N (2002): Epidermal transglutaminase (TGase 3) is the autoantigen of dermatitis herpetiformis. *J Exp Med* 195:747-757.

Sategna-Guidetti C, Grosso SB, Grosso S, Mengozzi G, Aimo G, Zaccaria T, Di Stefano M and Isaia GC (2000): The effects of 1-year gluten withdrawal on bone mass, bone metabolism and nutritional status in newly-diagnosed adult coeliac disease patients. *Aliment Pharmacol Ther.* 14:35-43.

Saukkonen T, Savilahti E, Reijonen H, Ilonen J, Tuomilehto-Wolf E and Akerblom HK (1996): Coeliac disease: frequent occurrence after clinical onset of insulin-dependent diabetes mellitus. Childhood Diabetes in Finland Study Group. *Diabet Med* 13:464-470.

Savilahti E, Reunala T and Mäki M (1992): Increase of lymphocytes bearing the gamma/delta T cell receptor in the jejunum of patients with dermatitis herpetiformis. *Gut* 33:206-211.

Schuppan D (2000): Current concepts of coeliac disease pathogenesis. *Gastroenterology* 119:234-242.

Seah PP, Fry L, Hoffbrand AV and Holborow EJ (1971): Tissue antibodies in dermatitis herpetiformis and coeliac disease. *Lancet* ii:834-836.

Selby WS, Painter D, Collins A, Faulkner-Hogg KB and Loblay RH (1999): Persistent mucosal abnormalities in coeliac disease are not related to the ingestion of trace amounts of gluten. *Scand J Gastroenterol* 34:909-914.

- Shah A, Mayberry JF, Williams G, Holt P, Loft DE and Rhodes J (1990): Epidemiological survey of coeliac disease and inflammatory bowel disease in first-degree relatives of coeliac patients. *Q J Med* 74:283-288.
- Sigurgeirsson B, Agnarsson BA and Lindelöf B (1994): Risk of lymphoma in patients with dermatitis herpetiformis. *BMJ* 308:13-15.
- Smith JB, Tulloch JE, Meyer LJ and Zone JJ (1992): The incidence and prevalence of dermatitis herpetiformis in Utah. *Arch Dermatol* 128:1608-1610.
- Snook JA, de Silva HJ and Jewell DP (1989): The association of autoimmune disorders with inflammatory bowel disease. *Q J Med* 72:835-840.
- Sollid LM, Markussen G, Ek J, Gjerde H, Vartdal F and Thorsby E (1989): Evidence for a primary association of coeliac disease to a particular HLA-DQ α/β heterodimer. *J Exp Med* 169:345-350.
- Sollid LM, Molberg O, McAdam S and Lundin KE (1997): Autoantibodies in coeliac disease: tissue transglutaminase - guilt by association? *Gut* 41:851-852.
- Spencer J, Isaacson PG, MacDonald TT, Thomas AJ and Walker-Smith JA (1991): Gamma/delta T cells and the diagnosis of coeliac disease. *Clin Exp Immunol* 85:109-113.
- Spurkland A, Sollid LM, Polanco I, Vartdal F and Thorsby E (1992): HLA-DR and -DQ genotypes of celiac disease patients serologically typed to be non-DR3 or non-DR5/7. *Hum Immunol* 35:188-192.
- Spurkland A, Ingvarsson G, Falk ES, Knutsen I, Sollid LM and Thorsby E (1997): Dermatitis herpetiformis and celiac disease are both primarily associated with the HLA-DQ (α 1*0501, β 1*02) or the HLA-DQ (α 1*03, β 1*0302) heterodimers. *Tissue Antigens* 49:29-34.
- Stern M, Ciclitira PJ, van Eckert R, Feighery C, Janssen FW, Mendez E, Mothes T, Troncone R and Wieser H (2001). Analysis and clinical effects of gluten in coeliac disease. *Eur J Gastroenterol Hepatol* 13:741-747.
- Stokes PL, Ferguson R, Holmes GK and Cooke WT (1976): Familial aspects of coeliac disease. *Q J Med* 45:567-582.
- Sulkanen S, Halttunen T, Laurila K, Kolho KL, Korponay-Szabo IR, Sarnesto A, Savilahti E, Collin P and Mäki M (1998): Tissue transglutaminase autoantibody enzyme-linked immunosorbent assay in detecting celiac disease. *Gastroenterology* 115:1322-1328.
- Swerdlow AJ, Whittaker S, Carpenter LM and English JS (1993): Mortality and cancer incidence in patients with dermatitis herpetiformis: a cohort study. *Br J Dermatol* 129:140-144.
- Swinson CM, Slavin G, Coles EC and Booth CC (1983): Coeliac disease and malignancy. *Lancet* 1:111-115.
- Trier JS (1991): Celiac sprue. *N Engl J Med* 325:1709-1719.
- Tuomilehto J, Karvonen M, Pitkaniemi J, Virtala E, Kohtamäki K, Toivanen L, Tuomilehto-Wolf E (1999): Record high incidence of type I (insulin-dependent) diabetes mellitus in Finnish children. *Diabetologica* 43: 682-684.

- Vainio E, Kalimo K, Reunala T, Viander M and Palosuo T (1983): Circulating IgA- and IgG-class antigliadin antibodies in dermatitis herpetiformis detected by enzyme-linked immunosorbent assay. *Arch Dermatol Res* 275:15-18.
- Valdimarsson T, Toss G, Ross I, Lofman O and Strom M (1994): Bone mineral density in coeliac disease. *Scand J Gastroenterol* 29:457-461.
- van der Meer JB (1969): Granular deposits of immunoglobulins in the skin of patients with dermatitis herpetiformis. An immunofluorescent study. *Br J Dermatol* 81:493-503.
- Vecchi M, Crosti L, Berti E, Agape D, Cerri A and De Franchis R (1992): Increased jejunal intraepithelial lymphocytes bearing gamma/delta T-cell receptor in dermatitis herpetiformis. *Gastroenterology* 102: 1499-1505.
- Visakorpi JK (1969): Diabetes and coeliac disease. *Lancet* 2:1192.
- Vogel F and Moltulsky AG (1997): Nature-nurture concept: twin method. In: *Human Genetics: Problems and Approaches*, p.228-240. Eds: Vogel F, Moltulsky AG, Springer-Verlag, Berlin.
- Vogelsang H, Genser D, Wyatt J, Lochs H, Ferenci P, Granditsch G and Penner E (1995): Screening for celiac disease: a prospective study on the value of noninvasive tests. *Am J Gastroenterol* 90:394-398.
- Volta U, Bellentani S, Bianchi FB, Brandi G, De Franceschi L, Miglioli L, Granito A, Balli F and Tiribelli C (2001): High prevalence of celiac disease in Italian general population. *Dig Dis Sci* 46:1500-1505.
- Volta U, Rodrigo L, Granito A, Petrolini N, Muratori P, Muratori L, Linares A, Veronesi L, Fuentes D, Zauli D and Bianchi FB (2002): Celiac disease in autoimmune cholestatic liver disorders. *Am J Gastroenterol* 97:2609-2613.
- Walker-Smith JA, Guandalini S, Schmitz J, Shmerling DH and Visakorpi JK (1990): Revised criteria for diagnosis of coeliac disease. *Arch Dis Child* 65:909-911.
- Walsh CH, Cooper BT, Wright AD, Malins JM and Cooke WT (1978): Diabetes mellitus and coeliac disease: a clinical study. *Q J Med* 47:89-100.
- Walters JR (1994): Bone mineral density in coeliac disease. *Gut* 35:150-151.
- Walton C and Walton S (1987): Primary biliary cirrhosis in a diabetic male with dermatitis herpetiformis. *Clin Exp Dermatol* 12: 46-47.
- Weinstein WM (1974): Latent coeliac sprue. *Gastroenterology* 66:489-493.
- West J, Logan RF, Card TR, Smith C and Hubbard R (2003): *Gastroenterology* 125:429-436.
- Wills AJ, Turner B, Lock RJ, Johnston SL, Unsworth DJ and Fry L (2002): Dermatitis herpetiformis and neurological dysfunction. *J Neurol Neurosurg Psychiatry* 72:259-261.
- Wolf R, Matz H, Orion E, Tuzun B and Tuzun Y (2002): Dapsone. *Derm Onl J* 8:2
- Working group appointed by the Finnish Society of Gastroenterology (1999): *Coeliac disease. Current Care Guidelines*. Helsinki: Finnish Medical Society Duodecim (updated on 09 June 1999). Available at internet: www.kaupahoito.fi

Wright DH, Jones DB, Clark H, Mead GM, Hodges E and Howell WM (1991): Is adult-onset coeliac disease due to a low-grade lymphoma of intraepithelial T lymphocytes? *Lancet* 337:1373-1374.

Zhong F, McCombs CC, Olson JM, Elston RC, Stevens FM, McCarthy CF and Michalski JP (1996): An autosomal screen for genes that predispose to celiac disease in the western counties of Ireland. *Nat Genet* 14:329-33.

Zone JJ, LaSalle BA and Provost TT (1982): Induction of IgA circulating immune complexes after wheat feeding in dermatitis herpetiformis patients. *J Invest Dermatol* 78:375-380.

Zone JJ, Meyer LJ and Petersen MJ (1996): Deposition of granular IgA relative to clinical lesions in dermatitis herpetiformis. *Arch Dermatol* 132:912-918.

ORIGINAL PUBLICATIONS