

Defining Bath Ankylosing Spondylitis Disease Activity Index Cut-off Values for Disease Activity States in a Multinational European Cohort of Patients With Axial Spondyloarthritis

Stylianos Georgiadis,¹ Lykke Midtbøll Ørnbjerg,¹ Brigitte Michelsen,² Tore K. Kvien,³ Mehrdad Shoaie Kazemi,¹ Jakub Závada,⁴ Karel Pavelka,⁴ Bente Grintborg,⁵ Anne Gitte Loft,⁶ Andreas Reich,⁷ Anne C. Regierer,⁷ Ana Maria Rodrigues,⁸ Maria José Santos,⁹ Jarno Rutanen,¹⁰ Laura Kuusalo,¹¹ Adrian Ciurea,¹² Michael J. Nissen,¹³ Bjorn Gudbjornsson,¹⁴ Ólafur Pálsson,¹⁵ Žiga Rotar,¹⁶ Katja Perdan Pirkmajer,¹⁶ Daniela Di Giuseppe,¹⁷ Mikkel Østergaard,¹⁸ and Merete Lund Hetland¹⁸

Objective. The Bath Ankylosing Spondylitis Disease Activity Index (BASDAI) is widely used for assessing disease activity in patients with axial spondyloarthritis (axSpA), particularly in settings where markers of inflammation are unavailable. As no consensus on BASDAI cut-off values exists for disease activity states in axSpA, we aimed to develop and validate such cut-offs against external criteria.

Methods. Routine care patients with axSpA initiating a biologic disease-modifying antirheumatic drug in eight European registries were included. Receiver operating characteristic analyses against external criteria were performed to determine optimal BASDAI values for separating remission, low disease activity (LDA), high disease activity (HDA), and very high disease activity (VHDA). Follow-up data at 6 months were used to select BASDAI cut-off values between remission and LDA and between LDA and HDA, whereas baseline data were used to select the cut-off for VHDA. The level of agreement between disease activity states based on BASDAI and Axial Spondyloarthritis Disease Activity Score (ASDAS) cut-off values was assessed using the proportion of discordance and weighted kappa.

Results. In this cohort of 4,633 patients, the optimal BASDAI cut-off values between remission, LDA, HDA and VHDA were estimated to be <1.3, <2.5, and >5.3. The proportions of discordance between BASDAI and ASDAS disease activity states were 27.6% (weighted $\kappa = 0.48$) in baseline data and 37.6% (weighted $\kappa = 0.28$) in 6-month data.

Conclusion. BASDAI cut-off values for separating remission, LDA, HDA and VHDA were estimated in >4,600 patients. These cut-off values can be used for assessing disease activity and monitoring patients with axSpA, particularly when laboratory markers are unavailable.

INTRODUCTION

Axial spondyloarthritis (axSpA) is a chronic inflammatory disease that involves the spine and sacroiliac joints, encompassing

both patients with nonradiographic axSpA and patients with radiographic axSpA.^{1,2} Regular monitoring of disease activity is essential for management and treatment of patients with axSpA.^{3,4} The two main outcome measures applied when

Supported by Novartis Pharma AG and UCB Biopharma SRL.

¹Stylianos Georgiadis, PhD, Lykke Midtbøll Ørnbjerg, MD, PhD, Mehrdad Shoaie Kazemi, MSc: Copenhagen Center for Arthritis Research (COPECARE), Center for Rheumatology and Spine Diseases, Centre for Head and Orthopaedics, Rigshospitalet, Glostrup, Denmark; ²Brigitte Michelsen, MD, PhD: COPECARE, Center for Rheumatology and Spine Diseases, Centre for Head and Orthopaedics, Rigshospitalet, Glostrup, Denmark, and Center for Treatment of Rheumatic and Musculoskeletal Diseases (REMEDY), Diakonhjemmet Hospital, Oslo, and Sørlandet Hospital, Kristiansand, Norway; ³Tore K. Kvien, MD, PhD: REMEDY, Diakonhjemmet Hospital, and the University of Oslo, Oslo, Norway; ⁴Jakub Závada, MD, PhD, Karel Pavelka, MD, PhD: Institute of Rheumatology and First Faculty of Medicine, Charles University, Prague, Czech Republic; ⁵Bente Grintborg, MD, PhD, DMSc: COPECARE, Center for Rheumatology and Spine Diseases, Centre for Head and Orthopaedics and DANBIO, Rigshospitalet, Glostrup, and the University of Copenhagen,

Copenhagen, Denmark; ⁶Anne Gitte Loft, MD, DMSc: Aarhus University Hospital and Aarhus University, Aarhus, Denmark; ⁷Andreas Reich, MSc, Anne C. Regierer, PhD: German Rheumatology Research Center, Berlin, Germany; ⁸Maria José Santos, MD, PhD: Hospital Garcia de Orta, Almada, and Instituto Medicina Molecular, Faculdade de Medicina da Universidade de Lisboa, Centro Académico de Medicina de Lisboa, Lisbon, Portugal; ⁹Ana Maria Rodrigues, MD, PhD: EpiDoC unit, Comprehensive Health Research Centre, Nova Medical School and Reuma.pt, Sociedade Portuguesa de Reumatologia, Lisbon, Portugal; ¹⁰Jarno Rutanen, MD, PhD: Centre for Rheumatic Disease, Tampere University Hospital and Tampere University, Tampere, Finland; ¹¹Laura Kuusalo, MD, PhD: Turku University Hospital and the University of Turku, Turku, Finland; ¹²Adrian Ciurea, MD: University Hospital Zurich and the University of Zurich, Zurich, Switzerland; ¹³Michael J. Nissen, MD, MBBS: Geneva University Hospital, Geneva, Switzerland; ¹⁴Bjorn Gudbjornsson, MD, PhD: Centre for Rheumatology Research, Landspítali University Hospital

SIGNIFICANCE & INNOVATIONS

- The BASDAI is a clinical measure used to assess disease activity in patients with axSpA.
- The unvalidated cut-off values of <2, <4, and >6 for disease activity states are commonly applied.
- We estimated, validated, and suggest new BASDAI cut-off values of <1.3, <2.5, and >5.3.

assessing disease activity in those with axSpA are the Bath Ankylosing Spondylitis Disease Activity Index (BASDAI)⁵ and the Axial Spondyloarthritis Disease Activity Score (ASDAS).^{6–8} The BASDAI is a patient-reported outcome measure addressing five domains,⁵ whereas the ASDAS is a composite disease activity score that consists of four questions reported by the patient and the C-reactive protein (CRP) level, according to a weighted formula.^{6,9}

The BASDAI has historically been the most widely used clinical measure to assess disease activity and monitor patients with axSpA; however, unlike the ASDAS, the BASDAI does not weigh each domain and does not incorporate an acute-phase reactant, which provides an important objective disease activity measure. Thus, the ASDAS has become the recommended outcome measure for use in both clinical practice and clinical trials^{4,10} and for selecting patients for treatment with biologics.^{11,12}

Nevertheless, the BASDAI is still commonly used, particularly in settings where inflammatory laboratory markers are unavailable. Moreover, a BASDAI value ≥ 4 , along with other inclusion criteria, is still required in many clinical trials.^{13–16} In analogy to the ASDAS cut-off values of <1.3, <2.1, and >3.5 for separating disease activity states, the BASDAI cut-off values of <2, <4, and >6 have been used to classify patients into remission (BASDAI <2), low disease activity (LDA; BASDAI value of 2–4), high disease activity (HDA; BASDAI value of 4–6), and very high disease activity (VHDA; BASDAI value >6).¹⁷ Although ASDAS cut-off values were established against external criteria, namely the Assessment of SpondyloArthritis international Society (ASAS) criteria for partial remission and patient and physician global assessments at predefined levels, BASDAI cut-off values of <2, <4, and >6 are arbitrarily chosen and remain unvalidated.^{17,18}

and University of Iceland, Reykjavik, Iceland; ¹⁵Ólafur Pálsson, MD: University of Iceland, Reykjavik, Iceland and the Department of Clinical Sciences Lund, Rheumatology, Lund University and Skåne University Hospital, Lund, Sweden; ¹⁶Ziga Rotar, MD, PhD, Katja Perdan Pirkmajer, MD, PhD: University Medical Centre Ljubljana and the University of Ljubljana, Ljubljana, Slovenia; ¹⁷Daniela Di Giuseppe, PhD: Clinical Epidemiology Division, Department of Medicine, Solna, Karolinska Institutet, Stockholm, Sweden; ¹⁸Mikkel Østergaard, MD, PhD, DMSc, Merete Lund Hetland, MD, PhD, DMSc: COPE-CARE, Center for Rheumatology and Spine Diseases, Centre for Head and Orthopaedics, Rigshospitalet, Glostrup, and the University of Copenhagen, Copenhagen, Denmark.

Georgiadis and Dr Ørnberg are co-first authors and contributed equally to this work. Drs Østergaard and Hetland are co-last authors and contributed equally to this work.

Four recent studies aimed to determine the BASDAI cut-off values corresponding to ASDAS cut-off values of <1.3, <2.1, and >3.5 in Asian cohorts.^{19–22} The selected BASDAI cut-off values between remission and LDA ranged from <0.8 to <2.1, those between LDA and HDA ranged from <2.5 to <3.5, and those between HDA and VHDA ranged from >3.7 to >6. The variations in the proposed BASDAI cut-off values indicate the need for further research to determine and validate the relevant BASDAI cut-off values for separation of disease activity states. Such cut-off values could alternatively be developed in a similar manner as the ASDAS cut-off values using several external criteria considered representative of the various disease activity states.

The aim of the current study, which includes a multinational European cohort of patients with axSpA, was to (1) determine BASDAI cut-off values against the same external criteria used to develop ASDAS cut-off values, (2) assess the level of agreement between BASDAI and ASDAS disease activity states, and (3) explore the impact of various patient and cohort characteristics on cut-off values for BASDAI disease activity states.

PATIENTS AND METHODS

Study population. This study relied on pooled data from eight European registries participating in the EuroSpA Research Collaboration Network,^{23,24} which register data on BASDAI and external disease activity criteria: ATTRA (Czech Republic), Biorx.si (Slovenia), DANBIO (Denmark), ICEBIO (Iceland), RABBIT-SpA (Germany), Reuma.pt (Portugal), ROB-FIN (Finland), and SCQM (Switzerland). Patients aged ≥ 18 years with a clinical diagnosis of axSpA (independent of the radiographic status) who initiated a tumor necrosis factor inhibitor (TNFi) or an interleukin-17A inhibitor (IL-17Ai) as a first biologic disease-modifying antirheumatic drug (bDMARD) between January 1, 2015, and December 31, 2023, were included in the study population.

Disease activity measures. The BASDAI value was calculated as the sum of four questions on fatigue (Q1), axial pain (Q2), peripheral joint pain/swelling (Q3), and tenderness at enthesal sites (Q4), plus the average of two questions on severity and duration of morning stiffness (Q5 and Q6, respectively), divided by

The data in this article were collected in the individual registries and made available for secondary use through the EuroSpA Research Collaboration Network (<https://eurospa.eu/#registries>). Relevant patient level data may be made available on reasonable request to the corresponding author but will require approval from all contributing registries.

Additional supplementary information cited in this article can be found online in the Supporting Information section (<https://acrjournals.onlinelibrary.wiley.com/doi/10.1002/acr2.70125>).

Author disclosures are available at <https://onlinelibrary.wiley.com/doi/10.1002/acr2.70125>.

Address correspondence via email to Stylianos Georgiadis, PhD, at stylianos.georgiadis@regionh.dk.

Submitted for publication April 17, 2025; accepted in revised form August 18, 2025.

five.⁵ The ASDAS value was calculated on the basis of four questions: back pain (BASDAI Q2), peripheral pain/swelling (BASDAI Q3), duration of morning stiffness (BASDAI Q6) and global disease activity, and CRP level (ie, $ASDAS = 0.121 \times [BASDAI Q2] + 0.110 \times [patient\ global\ assessment] + 0.073 \times [BASDAI Q3] + 0.058 \times [BASDAI Q6] + 0.579 \times \ln[\max(CRP, 2) + 1]$).^{6,9} The ASDAS cut-off values of <1.3, <2.1, and >3.5 were applied for separating disease activity states: inactive disease (ASDAS value <1.3), LDA (ASDAS value from 1.3 to <2.1), HDA (ASDAS value from 2.1 to ≤3.5), and VHDA (ASDAS value >3.5).^{18,25}

Approach for defining BASDAI cut-off values. To estimate the optimal BASDAI cut-off values, we largely adopted the methodology originally used to select ASDAS cut-off values by Machado et al²⁶ and afterward applied by Ørnbjerg et al.²⁷ The thresholds for patient and physician global assessments used to determine the BASDAI cut-off values between remission and LDA, between LDA and HDA, and between HDA and VHDA were ≤1, ≤3, and ≥6, respectively.²⁷ For separation of remission from LDA, an additional external criterion was ASAS partial remission, which includes assessment of four domains: patient global assessment, spinal pain (BASDAI Q2), physical function (Bath Ankylosing Spondylitis Functional Index), and inflammation (mean of morning stiffness-related BASDAI questions Q5 and Q6).²⁸ Because patients generally had the highest disease activity at treatment initiation, baseline data (between 90 days before and 30 days after treatment initiation) were used to select the cut-off value for VHDA, whereas data at 6 months (from 90 to 270 days after treatment initiation) were used to select the BASDAI cut-off value for remission and the cut-off value between LDA and HDA. Thus, only patients with a complete registration of the BASDAI and relevant external criteria at both baseline and 6-month visits were included in the primary analyses. A validation cohort was also created from patients excluded from the primary analyses who had a complete registration of both BASDAI and ASDAS but not on all relevant external criteria at any baseline or 6-month visit.

Ethics. Each participating registry had obtained the necessary approval from the relevant national data protection agency and ethical committee before transferring their data for this study (Table S1).

Statistical analyses. Descriptive analyses of the baseline patient characteristics were performed in patients included in the study population and those who were excluded. BASDAI and ASDAS scores, components, and disease activity states at baseline and 6 months were also reported.

Receiver operating characteristic (ROC) analyses against the predefined external criteria were used to estimate the BASDAI cut-off values. In alignment with the study by Machado et al,²⁶ the 90% specificity method was applied to select the cut-off

values for remission and between LDA and HDA, whereas the Youden index and the closest point to (0,1) methods were applied for the cut-off for VHDA. The 90% specificity method aim to avoid misclassifying patients in LDA, HDA, or VHDA as in remission. The Youden index method is based on the maximization of the true classification rate, whereas the closest point to (0,1) method defines the optimal cut-off value as the point minimizing the distance between the ROC curve and the (0,1) point, which represents the perfect situation with maximum sensitivity and specificity.²⁹ The overall cut-off value was calculated as the average of individual cut-off values across external criteria and across methods for selecting cut-off values. The stability of the selected optimal cut-off values was assessed by nonparametric bootstrapping,³⁰ according to which 1,000 bootstrap samples were drawn randomly with replacement from the original data and the optimal cut-off values were estimated in each sample. Additionally, the 95% confidence intervals (CIs) for the bootstrap samples were calculated. The level of agreement between disease activity states based on the estimated and unvalidated BASDAI cut-off values in baseline and 6-month follow-up data was measured using the proportion of discordance and weighted kappa with linear weights.

The relationship between the BASDAI and ASDAS values at baseline and 6-month visits, respectively, was assessed using Spearman's correlation coefficient. The level of agreement between disease activity states based on the BASDAI and ASDAS cut-off values was also investigated for both estimated and unvalidated BASDAI cut-off values. The level of agreement between BASDAI and ASDAS disease activity states was also assessed in the validation cohort.

To explore the potential impact of various patient characteristics on the BASDAI cut-off values, we performed separate ROC analyses against external criteria on patients stratified according to (1) sex, (2) age at treatment start (≤34 years, 35–44 years, and ≥45 years), (3) disease duration at treatment start (≤1 year, 2–5 years, and ≥6 years), (4) symptom duration at treatment start (≤2 years and ≥3 years), and (5) radiographic criteria (radiographic and nonradiographic axSpA). Additionally, we stratified patients according to cohort characteristics: (6) calendar year of treatment start (2015–2017, 2018–2020, and 2021–2023) and (7) registry.

As a sensitivity analysis, we estimated the BASDAI cut-off values corresponding to the ASDAS cut-off values (<1.3, <2.1, and >3.5). We conducted ROC analyses to determine the optimal BASDAI values corresponding to ASDAS cut-off values using the Youden index in line with previous studies.^{19–21} The level of agreement between disease activity states based on these BASDAI and ASDAS cut-off values was additionally assessed. These analyses were conducted on the subset of patients included in the primary analyses who also had a complete registration of ASDAS criteria at both baseline and 6-month visits. All analyses were conducted using R 4.2.2 software.³¹

RESULTS

Patient characteristics. Among 11,234 patients with axSpA in the eight European registries, 6,601 patients were excluded because of missing assessment of either the BASDAI or an external criterion at baseline or at 6 months. The 4,633 patients included in the study population were 61% male, with a median age of 42 (interquartile range 33–51) years and disease duration of 3 (interquartile range 1–8) years (Table 1). The mean values at baseline and 6 months were 5.8 (standard deviation [SD] 1.9) and 2.9 (SD 2.2), respectively, for the BASDAI and 3.7 (SD 0.9) and 2.0 (SD 1.0), respectively, for the ASDAS (see Table S2 for corresponding values of BASDAI and ASDAS components and disease activity states per time point). Compared to the included patients, excluded patients were more often female and less often HLA-B27 positive, whereas more of them fulfilled the criteria for radiographic axSpA (Table 1). Moreover, excluded patients had lower CRP levels at both baseline and 6 months and lower BASDAI and ASDAS values at baseline but slightly higher disease activity at 6 months (Table S1). Among the 6,601 patients excluded from the study population, 4,311 patients were included in the validation cohort. Patient characteristics and disease activity in the validation cohort were similar to that of the excluded patients (Tables S3 and S4).

Estimated BASDAI cut-off values. The BASDAI cut-off values for remission, between LDA and HDA, and for VHDA against the predefined external criteria were <1.3, <2.5, and >5.3, respectively (Table 2 and Figure S1). Among the methods applied to select the cut-off values, consistent results for cut-off values corresponding to patient and physician global criteria were observed, whereas discrepancies were shown for VHDA. In addition, the cut-off corresponding to ASAS partial remission was slightly lower than for patient and physician global criteria. The stability of the optimal BASDAI cut-off values was assessed by bootstrapping. Of the 1,000 bootstrap samples, 1.3, 2.5, and 5.4 were selected in 52%, 53%, and 24% of the bootstrap samples, respectively. The second most frequently selected values were 1.4, 2.4, and 5.3 in 48%, 28%, and 23% of the bootstrap samples, respectively. The 95% CIs were 1.3 to 1.4, 2.4 to 2.6, and 5.2 to 5.7, respectively. Frequencies of selection for cut-off values are shown in Figure S2. Comparing the estimated BASDAI cut-off values (<1.3, 2.5, and >5.3) and the unvalidated ones (<2, <4, and >6), we observed that 25.8% (weighted $\kappa = 0.62$, $P < 0.001$) and 39.3% (weighted $\kappa = 0.57$, $P < 0.001$) of the 4,633 patients changed disease activity states at baseline and 6 months, respectively (Table S5). A graphical representation of BASDAI disease activity states according to the unvalidated and estimated cut-off values is given in Figure 1.

Level of agreement between BASDAI and ASDAS states. The correlation between BASDAI and ASDAS values

was strong ($\rho = 0.74$, $P < 0.001$) and very strong ($\rho = 0.89$, $P < 0.001$) at baseline and 6 months, respectively (Figure S3). The proportions of discordance between disease activity states based on the unvalidated BASDAI cut-off values (<2, <4, and >6) and ASDAS cut-off values (<1.3, <2.1, and >3.5) were 35.9% (weighted $\kappa = 0.40$, $P < 0.001$) and 35.6% (weighted $\kappa = 0.30$, $P < 0.001$) at baseline and 6 months, respectively (Figure 2 and Table S6). Considering the estimated BASDAI cut-off values (<1.3, <2.5, and >5.3), the proportion of discordance between disease activity states based on the BASDAI and the established ASDAS cut-off values was lower (27.6%) at baseline and slightly higher (37.6%) at 6 months, with corresponding weighted κ values of 0.48 ($P < 0.001$) and 0.28 ($P < 0.001$) (Figure 2 and Table S7). When applying the estimated BASDAI cut-off values in the validation cohort, the proportions of discordance between BASDAI and ASDAS disease activity states were 32.5% (weighted $\kappa = 0.41$, $P < 0.001$) and 41.0% (weighted $\kappa = 0.22$, $P < 0.001$) at baseline and 6 months, respectively (Table S8).

Impact of patient characteristics. Stratification based on all five patient characteristics led to variation in the estimated BASDAI cut-off values (Table 3); cut-off values between remission and LDA ranged from <1.1 to <1.6, those between LDA and HDA ranged from <2.1 to <2.8, and those between HDA and VHDA ranged from >5.1 to >6.3. Differences across calendar year of treatment start were observed in cut-off values between LDA and HDA and between HDA and VHDA (Table 3). Across registries, BASDAI cut-off values differed markedly (Table 3). Notably, the estimated cut-off values between the four disease activity states for the two largest registries in the study population were <1.2, <2.3, and >6.3 for ATTRA (54% of patients in the study population) and <2.0, <3.6, and >5.2 for DANBIO (14% of patients in the study population).

Sensitivity analyses. The optimal BASDAI values for remission, between LDA and HDA, and for VHDA corresponding to ASDAS cut-off values of <1.3, <2.1, and >3.5 were <1.7, <2.8, and >5.6, respectively (Table S9). The proportion of discordance between disease activity states based on the BASDAI and ASDAS cut-off values was 28.8% at baseline and 34.4% at 6 months, with corresponding weighted κ values of 0.47 ($P < 0.001$) and 0.31 ($P < 0.001$) (Table S10).

DISCUSSION

In this study, we developed cut-off values for the BASDAI in a large multinational cohort of patients with axSpA initiating treatment with either a TNFi or an IL-17Ai. Interestingly, the estimated BASDAI cut-off values for disease activity states (<1.3, <2.5, and >5.3) were markedly lower than the unvalidated cut-off values usually applied in clinical trials and routine care (<2, <4, and >6). Applying these new estimated cut-off values instead of the

Table 1. Baseline patient characteristics in patients included in primary analyses and in patients excluded from primary analyses*

Patient characteristic	Included patients (n = 4,633)		Excluded patients (n = 6,601)	
	Available data	Value	Available data	Value
Age at treatment start, median (IQR), y	4,633 (100%)	42 (33–51)	6,601 (100%)	42 (32–51)
Time since diagnosis, median (IQR), y	4,282 (92%)	3 (1–8)	5,371 (81%)	2 (1–8)
Time since symptom onset, median (IQR), y	4,034 (87%)	8 (3–16)	3,997 (61%)	6 (2–12)
Male, n (%)	4,633 (100%)	2,803 (61%)	6,601 (100%)	3,578 (54%)
BMI, median (IQR), kg/m ²	3,766 (81%)	26.3 (23.3–29.9)	3,561 (54%)	26.0 (23.1–29.6)
Smoking status, current, n (%)	4,389 (95%)	1,405 (32%)	5,196 (79%)	1,540 (30%)
Registry, n (%)	4,633 (100%)		6,601 (100%)	
ATTRA		2,484 (54%)		621 (9%)
Biorx.si		40 (1%)		314 (5%)
DANBIO		649 (14%)		1,853 (28%)
ICEBIO		78 (2%)		384 (6%)
RABBIT-SpA		600 (13%)		310 (5%)
Reuma.pt		489 (11%)		1,469 (22%)
ROB-FIN		172 (4%)		854 (13%)
SCQM		121 (3%)		796 (12%)
HLA-B27-positive, n (%)	4,301 (93%)	3,442 (80%)	5,155 (78%)	3,661 (71%)
Concomitant csDMARD, n (%)	4,264 (92%)	1,220 (29%)	5,257 (80%)	1,626 (31%)
Presence of arthritis, n (%)	1,132 (24%)	469 (41%)	2,561 (39%)	1,047 (41%)
Radiographic axSpA, n (%) ^a	2,773 (60%)	2,353 (85%)	1,979 (30%)	1,613 (82%)
bDMARD type, n (%)	4,633 (100%)		6,601 (100%)	
TNFi		4,277 (92%)		6,296 (95%)
IL-17Ai		356 (8%)		305 (5%)
bDMARD start year, n (%)	4,633 (100%)		6,601 (100%)	
2015–2017		1,310 (28%)		2,086 (32%)
2018–2020		1,815 (39%)		2,456 (37%)
2021–2023		1,508 (33%)		2,059 (31%)
CRP level, median (IQR), mg/L	4,504 (97%)	12.0 (5.0–22.7)	4,304 (65%)	6.4 (2.0–16.2)
Patient global assessment, median (IQR), 0–10	4,633 (100%)	7 (5–8)	3,943 (60%)	7 (5–8)
Physician global assessment, median (IQR), 0–10	4,633 (100%)	6 (4–7)	2,867 (43%)	4 (2–6)
HAQ, median (IQR), 0–3	3,176 (69%)	1.0 (0.6–1.5)	2,683 (41%)	0.9 (0.5–1.2)
BASDAI Q1 (fatigue), median (IQR), 0–10	4,633 (100%)	7 (5–8)	4,118 (62%)	7 (5–8)
BASDAI Q2 (axial pain), median (IQR), 0–10	4,633 (100%)	7 (6–8)	4,142 (63%)	7 (5–8)
BASDAI Q3 (joint pain/swelling), median (IQR), 0–10	4,633 (100%)	5 (2–7)	4,141 (63%)	5 (2–7)
BASDAI Q4 (tenderness), median (IQR), 0–10	4,633 (100%)	6 (3–8)	4,115 (62%)	5 (3–8)
BASDAI Q5 (stiffness severity), median (IQR), 0–10	4,633 (100%)	7 (5–8)	4,117 (62%)	7 (5–8)
BASDAI Q6 (stiffness duration), median (IQR), 0–10	4,633 (100%)	5 (3–8)	4,134 (63%)	5 (3–8)
BASDAI, median (IQR), 0–10	4,633 (100%)	6.0 (4.6–7.3)	4,098 (62%)	5.8 (4.3–7.2)
BASFI, median (IQR), 0–10	4,526 (98%)	4.9 (2.8–6.7)	3,882 (59%)	4.4 (2.4–6.4)
ASDAS, median (IQR)	4,504 (97%)	3.7 (3.1–4.3)	3,145 (48%)	3.4 (2.8–4.1)

*Patients were included if they had available assessment of BASDAI and external criteria (ASAS partial remission and patient and physician global assessments) at baseline and at 6 months' follow-up. Patient-reported outcomes and physician global assessment, which were registered on a 0–100 scale in certain registries, were harmonized to a common 0–10 scale by rounding 0–100 to the nearest 10; relevant composite scores were calculated accordingly. ASAS, Assessment of SpondyloArthritis international Society; ASDAS, Axial Spondyloarthritis Disease Activity Score based on CRP level; axSpA, axial spondyloarthritis; BASDAI, Bath Ankylosing Spondylitis Disease Activity Index; BASFI, Bath Ankylosing Spondylitis Functional Index; bDMARD, biologic disease-modifying antirheumatic drug; BMI, body mass index; csDMARD, conventional synthetic disease-modifying antirheumatic drug; CRP, C-reactive protein; HAQ, Health Assessment Questionnaire; IL-17Ai, interleukin-17A inhibitor; IQR, interquartile range; TNFi, tumor necrosis factor inhibitor.

^aRadiographic axSpA was defined by bilateral grade 2–4 or unilateral grade 3–4 sacroiliitis on plain radiographs, according to the modified New York criteria.⁴⁵

Table 2. BASDAI cut-off values for disease activity states against external criteria*

	n (P+N)	90% SP (SE/SP)	Youden (SE/SP)	(0,1) (SE/SP)	AUC
BASDAI cut-off value between remission and LDA					
ASAS partial remission	4,633 (1,007+3,626)	<1.2 (0.89/0.91)	<1.3 (0.92/0.89)	<1.3 (0.92/0.89)	0.96
Patient global assessment ≤ 1	4,633 (1,461+3,172)	<1.4 (0.76/0.91)	<1.8 (0.85/0.84)	<1.8 (0.85/0.84)	0.92
Physician global assessment ≤ 1	4,633 (2,562+2,071)	<1.3 (0.44/0.91)	<2.3 (0.65/0.74)	<2.3 (0.65/0.74)	0.75
BASDAI cut-off value between LDA and HDA					
Patient global assessment ≤ 3	4,633 (2,890+1,743)	<2.4 (0.74/0.91)	<3.2 (0.89/0.81)	<3.0 (0.86/0.83)	0.93
Physician global assessment ≤ 3	4,633 (3,996+637)	<2.5 (0.58/0.90)	<3.3 (0.71/0.80)	<3.6 (0.74/0.76)	0.82
BASDAI cut-off value between HDA and VHDA					
Patient global assessment ≥ 6	4,633 (3,201+1,432)	>6.5 (0.51/0.90)	>5.3 (0.78/0.72)	>5.4 (0.76/0.73)	0.83
Physician global assessment ≥ 6	4,633 (2,506+2,127)	>7.8 (0.19/0.90)	>4.9 (0.78/0.40)	>5.9 (0.59/0.59)	0.63

*Bold indicates the optimal BASDAI values according to which the overall cut-off values were calculated as their average. Patient and physician global assessment scores were on a 0–10 integer scale. “(0,1)” indicates the cut-off according to the closest point to (0,1) method, “90% SP” indicates the cut-off according to the 90% specificity method, and “Youden” indicates the cut-off according to the Youden index method. ASAS, Assessment of SpondyloArthritis international Society; AUC, area under the curve; BASDAI, Bath Ankylosing Spondylitis Disease Activity Index; HDA, high disease activity; LDA, low disease activity; N, negative (number of patients not fulfilling the relevant criterion); P, positive (number of patients fulfilling the relevant criterion); SE, sensitivity; SP, specificity; VHDA, very high disease activity.

previous unvalidated ones yielded an increase in agreement in classification of patients into disease activity states according to BASDAI and ASDAS values at baseline but not at follow-up. Further analyses demonstrated differences in BASDAI cut-off values when they were developed in patients stratified by certain patient or cohort characteristics.

The most frequently applied BASDAI cut-off value for discriminating between LDA and HDA is BASDAI <4.^{4,32} However, previous studies have presented considerable discrepancies in the classification of patients into LDA and HDA according to

BASDAI values <4 and ASDAS values <2.1.^{11,12,33,34} A definition of a BASDAI value ≤ 3 for LDA has previously been occasionally applied.^{35,36} In the study in which the ASDAS cut-off values were developed, the BASDAI cut-off value that best corresponded to the external criteria was between <3.0 and <3.5.²⁶ Further evidence about the inadequacy of BASDAI values <4 has been presented in recent studies. Koo et al³⁷ found that even in patients with ankylosing spondylitis attaining a BASDAI value <4 during TNFi treatment, the CRP level was significantly correlated with radiographic progression. Braun et al³⁸ showed that patients

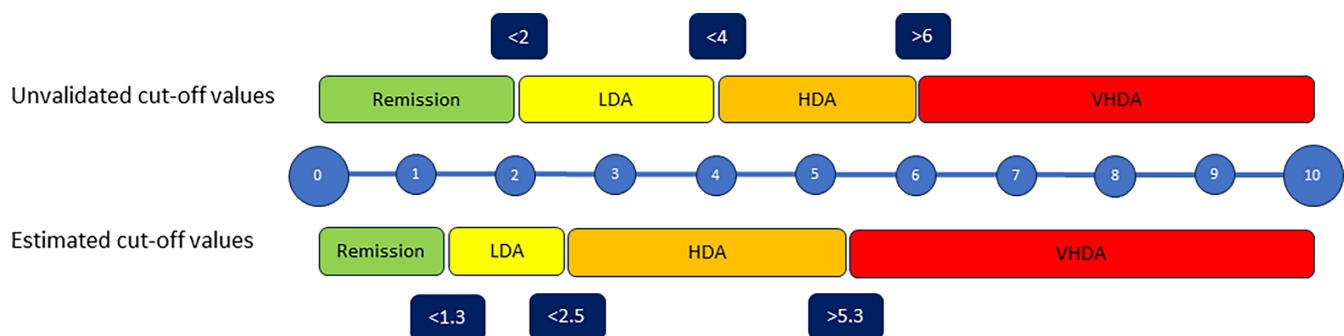
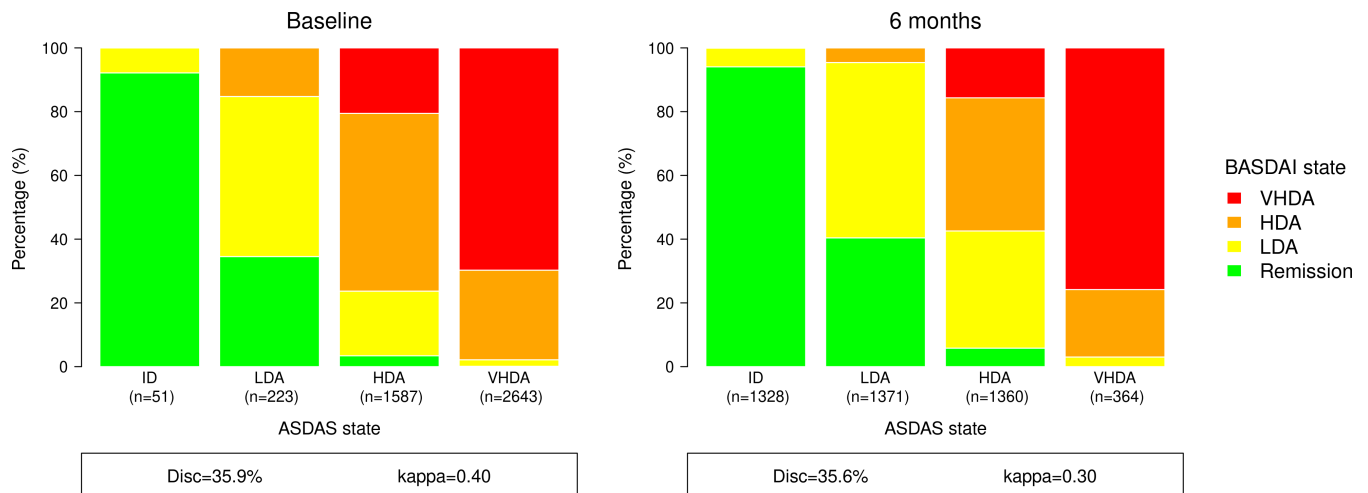

Figure 1. Bath Ankylosing Spondylitis Disease Activity Index disease activity states according to unvalidated cut-off values (<2, <4, and >6) and estimated cut-off values (<1.3, <2.5, and >5.3). HDA, high disease activity; LDA, low disease activity; VHDA, very high disease activity.

A. Unvalidated BASDAI cut-off values



B. Estimated BASDAI cut-off values

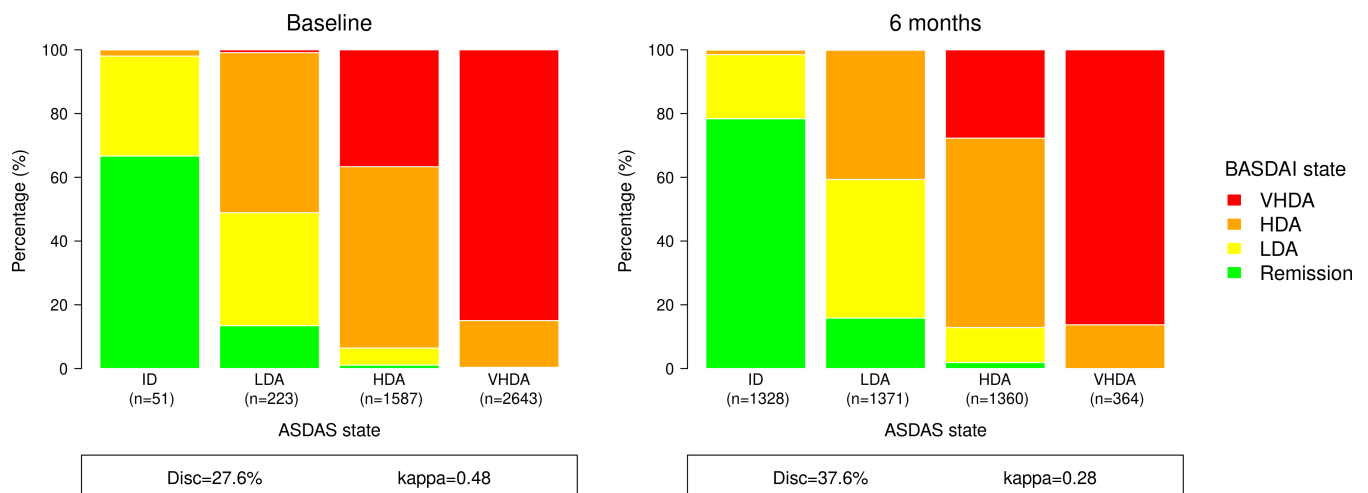

Figure 2. Stacked bar charts of BASDAI disease activity states dependent on ASDAS states (<1.3, <2.1, and >3.5), based on (A) unvalidated BASDAI cut-off values (<2, <4, and >6) and (B) estimated BASDAI cut-off values (<1.4, <2.8, and >5.9). ASDAS, Axial Spondyloarthritis Disease Activity Score; BASDAI, Bath Ankylosing Spondylitis Disease Activity Index; Disc, proportion of discordance; HDA, high disease activity; ID, inactive disease; kappa, weighted kappa; LDA, low disease activity; VHDA, very high disease activity.

with ankylosing spondylitis with a BASDAI value between 2.8 and 4 seemed significantly benefit from TNFi therapy, whereas this was not the case in patients with a BASDAI value <2.8.

Four studies have previously attempted to define the BASDAI cut-off values: three in patients with axSpA^{20–22} and one in patients with ankylosing spondylitis.¹⁹ In a South Korean cohort of 333 patients with axSpA, Kwon and Park²⁰ estimated the BASDAI cut-off values to be <1.9, <3.5, and >4.9. In a Chinese cohort of 489 patients with axSpA, Cui et al²¹ determined the cut-off values to be <1.6, <2.9, and >3.8. In a Taiwanese cohort of 489 patients with ankylosing spondylitis, Chen et al¹⁹ found BASDAI cut-off values of <2.1, <3.1, and >3.7. Goswami et al²² estimated BASDAI cut-off values of <0.8, <2.1, and >6.0 in 266 patients with axSpA from an effectiveness trial in India. We consider the study population and methodology used in our study

to provide more generalizable and accurate BASDAI cut-off values, particularly across Europe because we analyzed data from a large multinational European cohort of patients with axSpA, contrary to small sample sizes of a single Asian ethnicity in previous studies. Additionally, patients in our cohort were treated in routine care, and no specific inclusion criteria were applied. All four previously discussed studies selected the BASDAI cut-off values corresponding to ASDAS cut-off values for disease activity states (<1.3, <2.1, and >3.5): three of them by applying ROC analyses with the Youden method^{19–21} and one by performing multinomial logistic regression.²² Instead, we chose to define them following a similar approach used to develop ASDAS cut-off values (ie, against predefined external criteria considered to be representative of the various disease activity states).²⁶ Determining the BASDAI cut-off values corresponding to ASDAS

Table 3. BASDAI cut-off values for disease activity states selected in the entire study population and in cohorts stratified by patient and cohort characteristics*

Stratifications	Number of patients	Cut-off value between remission and LDA	Cut-off value between LDA and HDA	Cut-off value between HDA and VHDA
Overall	4,633	<1.3	<2.5	>5.3
Sex				
Male	2,803	<1.3	<2.3	>5.6
Female	1,830	<1.5	<2.8	>5.4
Age				
≤34 y	1,322	<1.1	<2.2	>5.1
35–44 y	1,389	<1.3	<2.3	>5.4
≥45 y	1,922	<1.6	<2.8	>5.6
Disease duration				
≤1 y	1,693	<1.3	<2.3	>5.4
2–5 y	1,058	<1.4	<2.4	>5.3
≥6 y	1,531	<1.4	<2.7	>5.9
Symptom duration				
≤2 y	808	<1.3	<2.4	>5.2
≥3 y	3,226	<1.3	<2.5	>5.6
Radiographic criteria ^a				
Radiographic axSpA	2,353	<1.2	<2.5	>6.3
Nonradiographic axSpA	420	<1.2	<2.1	>5.8
Calendar year				
2015–2017	1,310	<1.4	<2.7	>5.9
2018–2020	1,815	<1.4	<2.5	>5.2
2021–2023	1,508	<1.3	<2.3	>5.3
Registry				
ATTRA	2,484	<1.2	<2.3	>6.3
Biorx.si	40	–	–	–
DANBIO	649	<2.0	<3.6	>5.2
ICEBIO	78	<1.1	<2.6	>4.9
RABBIT-SpA	600	<1.5	<2.3	>4.4
Reuma.pt	489	<1.6	<2.8	>5.3
ROB-FIN	172	<1.5	<3.0	>4.5
SCQM	121	<1.8	<3.1	>5.4

*Cut-off values were not presented for registries with <50 patients included in the analyses. axSpA, axial spondyloarthritis; BASDAI, Bath Ankylosing Spondylitis Disease Activity Index; DANBIO, Danish Registry for Biologic Therapies in Rheumatology; HDA, high disease activity; LDA, low disease activity; SCQM, Swiss Clinical Quality Management; VHDA, very high disease activity.

^aRadiographic criteria were defined by bilateral grade 2–4 or unilateral grade 3–4 sacroiliitis on plain radiographs, according to the modified New York criteria.⁴⁵

cut-off values for disease activity states in our data gave higher BASDAI cut-off values (<1.7, <2.8, and >5.6) than BASDAI cut-off values against external criteria (<1.3, <2.5, and >5.3). We note that the BASDAI cut-off values between remission and LDA and between LDA and HDA were closer to the ones presented in the previous studies, in which a similar approach was applied.^{19–22} Moreover, to have the best representation of the disease activity states, we used two distinct time points to select the BASDAI cut-off values between disease activity states.²⁶ The use of different time points to select the BASDAI cut-off values is an advantage of our study compared to the other three studies,^{19–22} particularly for BASDAI cut-off values separating HDA and VHDA, as few patients were classified into VHDA. The variations across the estimated BASDAI cut-off values may also be justified by the differences in patient characteristics in the various cohorts, such

as demographics and disease activity. Notably, contrary to the previous three studies, patients in our study population were more often female, and they were all treated with a bDMARD.

To date, only the BASDAI cut-off values suggested by Kwon and Park²⁰ have been applied in practice.^{39–42} When applying these BASDAI cut-off values (<1.9, <3.5, and >4.9) in our data, the proportions of discordance between BASDAI and ASDAS disease activity states were 31.3% (weighted $\kappa = 0.40$, $P < 0.001$) and 38.4% (weighted $\kappa = 0.23$, $P < 0.001$) at baseline and 6 months, respectively (data not shown), which were higher than those with the cut-off values calculated in the present study against either external criteria (<1.3, <2.5, and >5.3) or with ASDAS cut-off values (<1.7, <2.8, and >5.6).

Our findings showed that the level of agreement between BASDAI and ASDAS disease activity states was higher at baseline

than at follow-up. Nevertheless, the level of agreement at both time points was moderate, which reflects that the underlying domains of the BASDAI and ASDAS are not identical. Particularly, the BASDAI does not incorporate an objective parameter of inflammation, which may account for the discrepancies between disease activity states according to BASDAI and ASDAS values. An alternative composite score that combines BASDAI value and CRP level has been proposed.⁴³

Variations in the selected BASDAI cut-off values in cohorts stratified by patient characteristics were observed. These variations are more evident than the variations previously published for the ASDAS cut-off values.²⁷ The widest range of selected BASDAI cut-off values was observed in cohorts stratified by registry. This may reflect the heterogeneity in the setup, data collection, patient characteristics, and access to treatment, as well as the data availability and completeness of measures in routine care across registries.²⁴ Particularly, patient-reported outcomes used in the development of the BASDAI cut-off values, along with the physician global assessment, varied markedly across the registries. The mean patient global assessment varied from 4.3 (SD 2.7) to 7.5 (SD 1.7) at baseline and from 2.3 (SD 2.8) to 4.3 (SD 3.2) at the 6-month follow-up, whereas the physician global assessment ranged from 2.6 (SD 2.0) to 6.1 (SD 2.3) at baseline and from 0.9 (SD 1.4) to 2.1 (SD 1.9) at the 6-month follow-up (data not shown). Regarding the BASDAI cut-off values identified in the overall study population, we attempted to deal with the challenge of the heterogeneity in the study population by performing bootstrap stability analyses. The differences in the proportions of registries contributing data in the study population and the validation cohort might explain why the level of agreement between BASDAI and ASDAS disease activity states at both baseline and 6 months were poorer in the validation cohort than in the study population.

Our study has some noteworthy limitations. First, patients included in this study may not be representative of the overall population of patients with axSpA in each registry because of the selection of patients with available data on the BASDAI and the external disease activity criteria. These may not be similar to patients with missing data, and thus selection bias cannot be excluded. Secondly, a limitation of the current study is the absence of trustworthy information on comorbidities, such as osteoarthritis and fibromyalgia, which have been associated with higher patient-reported disease activity in axSpA⁴⁴ and therefore may have an impact on the BASDAI cut-off values for disease activity states. Finally, the level of agreement between the BASDAI and ASDAS disease activity states and the estimation of the BASDAI cut-off values corresponding to the ASDAS cut-off values might have been affected by abnormally elevated CRP levels. Potential reasons were active infections or malignancies due to no strict inclusion criteria of patients in our study and the various detection limits for measurement of CRP levels used across registries.

Our findings support that the BASDAI is a valuable tool for assessing disease activity and monitoring patients with axSpA. Further research should be performed to validate the proposed BASDAI cut-off values for disease activity states in other cohorts. The impact of these cut-off values in clinical trials and clinical practice is a topic of future research.

In conclusion, we estimated BASDAI cut-off values for separating remission, LDA, HDA, and VHDA states against predefined external criteria to be <1.3, <2.5, and >5.3 in a large multinational European observational cohort of patients with axSpA. These values can be applied to assess disease activity in clinical practice and in clinical trials, particularly when laboratory markers are not available.

ACKNOWLEDGMENTS

The EuroSpA collaboration has been supported by Novartis Pharma AG since 2017 and UCB Biopharma SRL since 2022.

AUTHOR CONTRIBUTIONS

All authors contributed to at least one of the following manuscript preparation roles: conceptualization AND/OR methodology, software, investigation, formal analysis, data curation, visualization, and validation AND drafting or reviewing/editing the final draft. As corresponding author, Georgiadis confirms that all authors have provided the final approval of the version to be published and takes responsibility for the affirmations regarding article submission (eg, not under consideration by another journal), the integrity of the data presented, and the statements regarding compliance with institutional review board/Declaration of Helsinki requirements.

ROLE OF THE STUDY SPONSOR

Novartis had no influence on the data collection, statistical analyses, manuscript preparation, or decision to submit the manuscript for publication. Publication of this article was not contingent upon approval by Novartis.

REFERENCES

1. Rudwaleit M, van der Heijde D, Landewé R, et al. The development of Assessment of SpondyloArthritis international Society classification criteria for axial spondyloarthritis (part II): validation and final selection. *Ann Rheum Dis* 2009;68(6):777–783.
2. Sieper J, Poddubnyy D. Axial spondyloarthritis. *Lancet* 2017;390(10089):73–84.
3. Ward MM, Deodhar A, Gensler LS, et al. 2019 Update of the American College of Rheumatology/Spondylitis Association of America/Spondyloarthritis Research and Treatment Network recommendations for the treatment of ankylosing spondylitis and nonradiographic axial spondyloarthritis. *Arthritis Rheumatol* 2019;71(10):1599–1613.
4. Ramiro S, Nikiphorou E, Sepiano A, et al. ASAS-EULAR recommendations for the management of axial spondyloarthritis: 2022 update. *Ann Rheum Dis* 2022;71:1–16.
5. Garrett S, Jenkinson T, Kennedy LG, et al. A new approach to defining disease status in ankylosing spondylitis: the Bath Ankylosing Spondylitis Disease Activity Index. *J Rheumatol* 1994;21(12):2286–2291.

6. Lukas C, Landewé R, Sieper J, et al; Assessment of SpondyloArthritis international Society. Development of an ASAS-endorsed disease activity score (ASDAS) in patients with ankylosing spondylitis. *Ann Rheum Dis* 2009;68(1):18–24.
7. van der Heijde D, Lie E, Kvien TK, et al; Assessment of SpondyloArthritis international Society (ASAS). ASDAS, a highly discriminatory ASAS-endorsed disease activity score in patients with ankylosing spondylitis. *Ann Rheum Dis* 2009;68(12):1811–1818.
8. van der Heijde D, Molto A, Ramiro S, et al. Goodbye to the term ‘ankylosing spondylitis’, hello ‘axial spondyloarthritis’: time to embrace the ASAS-defined nomenclature. *Ann Rheum Dis* 2024;83(5):547–549.
9. Machado P, Navarro-Compán V, Landewé R, et al. Calculating the ankylosing spondylitis disease activity score if the conventional C-reactive protein level is below the limit of detection or if high-sensitivity C-reactive protein is used: an analysis in the DESIR cohort. *Arthritis Rheumatol* 2015;67(2):408–413.
10. Smolen JS, Schöls M, Braun J, et al. Treating axial spondyloarthritis and peripheral spondyloarthritis, especially psoriatic arthritis, to target: 2017 update of recommendations by an international task force. *Ann Rheum Dis* 2018;77(1):3–17.
11. Fagerli KM, Lie E, van der Heijde D, et al. Selecting patients with ankylosing spondylitis for TNF inhibitor therapy: comparison of ASDAS and BASDAI eligibility criteria. *Rheumatology (Oxford)* 2012;51(8):1479–1483.
12. Marona J, Sepriano A, Rodrigues-Manica S, et al. Eligibility criteria for biologic disease-modifying antirheumatic drugs in axial spondyloarthritis: going beyond BASDAI. *RMD Open* 2020;6(1):e001145.
13. Robinson PC, Maksymowych WP, Gensler LS, et al. Certolizumab pegol efficacy in patients with non-radiographic axial spondyloarthritis stratified by baseline MRI and C-reactive protein status: an analysis from the C-axSpAnd study. *ACR Open Rheumatol* 2022;4(9):794–801.
14. Kiltz U, van der Heijde D, Boonen A, et al. Clinimetric validation of the Assessment of Spondyloarthritis International Society Health Index in patients with radiographic axial spondyloarthritis in ixekizumab trials. *J Rheumatol* 2023;50(6):754–762.
15. Rusman T, van der Weijden M, Nurmohamed MT, et al. Does a short course of etanercept influence disease progression and radiographic changes in patients suspected of non-radiographic axial spondyloarthritis? Three-years follow-up of a placebo-controlled trial. *Scand J Rheumatol* 2023;52(2):137–141.
16. Maksymowych WP, Thom H, Mørup MF, et al. Matching-adjusted indirect comparison of the 52-week efficacy of bimekizumab versus secukinumab and ixekizumab for the treatment of radiographic axial spondyloarthritis. *Rheumatol Ther* 2024;11(4):1023–1041.
17. Ramiro S, van der Heijde D, van Tubergen A, et al. Higher disease activity leads to more structural damage in the spine in ankylosing spondylitis: 12-year longitudinal data from the OASIS cohort. *Ann Rheum Dis* 2014;73(8):1455–1461.
18. Machado P, Landewé R, Lie E, et al; Assessment of SpondyloArthritis international Society. Ankylosing Spondylitis Disease Activity Score (ASDAS): defining cut-off values for disease activity states and improvement scores. *Ann Rheum Dis* 2011;70(1):47–53.
19. Chen YH, Huang WN, Chen YM, et al. The BASDAI cut-off for disease activity corresponding to the ASDAS scores in a Taiwanese cohort of ankylosing spondylitis. *Front Med (Lausanne)* 2022;9:856654.
20. Kwon OC, Park MC. BASDAI cut-off values corresponding to ASDAS cut-off values. *Rheumatology (Oxford)* 2022;61(6):2369–2374.
21. Cui R, Du Y, Tian N, et al. Equivalent cut-off values of Bath Ankylosing Spondylitis Disease Activity Index corresponding to Ankylosing Spondylitis Disease Activity Score cut-off values. *Clin Exp Rheumatol* 2023;41(5):1163–1169.
22. Goswami RP, Chatterjee M, Das S. Defining Objective BASDAI cut-offs for disease activity states and improvement scores in axial spondyloarthritis: a multicentric collaboration. *Int J Rheum Dis* 2024;27(11):e15418.
23. Ørnbjerg LM, Brahe CH, Askling J, et al. Treatment response and drug retention rates in 24 195 biologic-naïve patients with axial spondyloarthritis initiating TNFi treatment: routine care data from 12 registries in the EuroSpA collaboration. *Ann Rheum Dis* 2019;78(11):1536–1544.
24. Linde L, Ørnbjerg LM, Rasmussen SH, et al. Commonalities and differences in set-up and data collection across European spondyloarthritis registries — results from the EuroSpA collaboration. *Arthritis Res Ther* 2023;25(1):1–14.
25. Machado PM, Landewé R, Heijde DV; Assessment of SpondyloArthritis international Society (ASAS). Ankylosing Spondylitis Disease Activity Score (ASDAS): 2018 update of the nomenclature for disease activity states. *Ann Rheum Dis* 2018;77(10):1539–1540.
26. Machado P, Landewé R, Lie E, et al; Assessment of SpondyloArthritis international Society. Ankylosing Spondylitis Disease Activity Score (ASDAS): defining cut-off values for disease activity states and improvement scores. *Ann Rheum Dis* 2011;70(1):47–53.
27. Ørnbjerg LM, Georgiadis S, Kvien TK, et al. Impact of patient characteristics on ASDAS disease activity state cut-offs in axial spondyloarthritis: results from nine European rheumatology registries. *RMD Open* 2024;10(4):e004644.
28. Anderson JJ, Baron G, van der Heijde D, et al. Ankylosing spondylitis assessment group preliminary definition of short-term improvement in ankylosing spondylitis. *Arthritis Rheum* 2001;44(8):1876–1886.
29. Perkins NJ, Schisterman EF. The inconsistency of “optimal” cutpoints obtained using two criteria based on the receiver operating characteristic curve. *Am J Epidemiol* 2006;163(7):670–675.
30. Davison. AC, Hinkley D V. *Bootstrap Methods and Their Application*. Cambridge University Press; 1997.
31. R Core Team. R: a language and environment for statistical computing. Accessed July 31, 2025. <https://www.r-project.org/>
32. Landewé R, van Tubergen A. Clinical tools to assess and monitor spondyloarthritis. *Curr Rheumatol Rep* 2015;17(7):47.
33. Vastesaeger N, Cruyssen BV, Mulero J, et al; REGISPONSER Working Group. ASDAS high disease activity versus BASDAI elevation in patients with ankylosing spondylitis as selection criterion for anti-TNF therapy. *Reumatol Clin* 2014;10(4):204–209.
34. Michielsens C, Bolhuis TE, van Gaalen FA, et al. Construct validity of Bath Ankylosing Spondylitis Disease Activity Index (BASDAI) and Ankylosing Spondylitis Disease Activity Score (ASDAS) treatment target cut-offs in a BASDAI treat-to-target axial spondyloarthritis cohort: a cross-sectional study. *Scand J Rheumatol* 2024;53(3):180–187.
35. Baraliakos X, Brandt J, Listing J, et al. Outcome of patients with active ankylosing spondylitis after two years of therapy with etanercept: clinical and magnetic resonance imaging data. *Arthritis Rheum* 2005;53(6):856–863.
36. Baraliakos X, Listing J, Brandt J, et al. Clinical response to discontinuation of anti-TNF therapy in patients with ankylosing spondylitis after 3 years of continuous treatment with infliximab. *Arthritis Res Ther* 2005;7(3):R439–R444.
37. Koo BS, Oh JS, Park SY, et al. Relationship between inflammation and radiographic progression in patients with ankylosing spondylitis attaining a BASDAI of less than 4 during tumor necrosis factor inhibitor treatment. *J Rheumatol* 2022;49(12):1328–1334.
38. Braun J, Baraliakos X, Kiltz U, et al. Disease activity cutoff values in initiating tumor necrosis factor inhibitor therapy in ankylosing spondylitis: a German GO-NICE study subanalysis. *J Rheumatol* 2020;47(1):35–41.
39. Öztürk Ö, Feyzioğlu Ö, Santaş F. Identifying frailty and its associated factors in patients with axial spondyloarthritis. *Int J Rheum Dis* 2023;26(3):519–530.

40. Bolt JW, Aalbers CJ, Walet L, et al. Treatment decisions in axial spondyloarthritis daily clinical practice are more than treat-to-target. *Rheumatology (Oxford)* 2024;63(1):34–40.
41. Fongen C, Dagfinrud H, Bilberg A, et al. Reduced sleep quality is highly prevalent and associated with physical function and cardiorespiratory fitness in patients with axial spondyloarthritis: a cross-sectional study. *Scand J Rheumatol* 2024;53(2):130–139.
42. Labinsky H, May S, Boy K, et al. Evaluation of a hybrid telehealth care pathway for patients with axial spondyloarthritis including self-sampling at home: results of a longitudinal proof-of-concept mixed-methods study (TeleSpactive). *Rheumatol Int* 2024;44(6):1133–1142.
43. Aranda-Valera IC, Garrido-Castro JL, Ladehesa-Pineda L, et al. How to calculate the ASDAS based on C-reactive protein without individual questions from the BASDAI: the BASDAI-based ASDAS formula. *Rheumatology (Oxford)* 2020;59(7):1545–1549.
44. Zhao SS, Jones GT, Macfarlane GJ, et al. Association between comorbidities and disease activity in axial spondyloarthritis: results from the BSRBR-AS. *Rheumatology (Oxford)* 2021;60(7):3189–3198.
45. van der Linden S, Valkenburg HA, Cats A. Evaluation of diagnostic criteria for ankylosing spondylitis. A proposal for modification of the New York criteria. *Arthritis Rheum* 1984;27(4):361–368.