

Decoupled Control to Improve DC-Link Dynamics of Energy-Storage-Equipped STATCOM

Hikmat Basnet 

Department of Electrical Engineering
Tampere University
Tampere, Finland
hikmat.basnet@tuni.fi

Tomi Roinila

Department of Electrical Engineering
Tampere University
Tampere, Finland
tomi.roinila@tuni.fi

Hossein Hafezi

Department of Electrical Engineering
Tampere University
Tampere, Finland
hossein.hafezi@tuni.fi

Roosa Sallinen

Department of Electrical Engineering
Tampere University
Tampere, Finland
roosa.sallinen@tuni.fi

Minh Tran

Department of Electrical Engineering
Tampere University
Tampere, Finland
minh.tran@tuni.fi

Abstract—Energy-storage-equipped static synchronous compensator (E-STATCOM) plays an important role in a modern power grid. Such a compensator can be efficiently applied to control the active and reactive power thus improving the voltage and frequency stability especially in a power grid that is dominated by renewable energy resources. A challenge using an E-STATCOM is to minimize the adverse effect of the AC components present in the DC-link voltage especially during charging and discharging of an energy-storage system (ESS). This paper proposes a novel application of the dq -decoupled control to minimize the undesired dynamical effect of the ESS on the DC-link voltage of the E-STATCOM. In this method active and reactive power are decoupled by eliminating the dq -frame cross-coupling terms using reference current produced by the power controller instead of the measured inductor current. Experimental measurements are shown to demonstrate the effectiveness of the proposed method.

Index Terms—E-STATCOM, Energy-Storage System, Decoupled Control, DC-Link Voltage

NOMENCLATURE

u_a, u_b, u_c	Three-phase line voltages.
u_d, u_q	Line voltage in dq -frame.
e_a, e_b, e_c	Three-phase E-STATCOM voltages.
e_d, e_q	E-STATCOM voltage in dq -frame.
e_d^*, e_q^*	Reference voltage in dq -frame.
i_a, i_b, i_c	Three-phase filter inductor current.
i_d, i_q	Filter inductor current in dq -frame.
i_d^*, i_q^*	Reference current in dq -frame.
R_G, L_G	Grid resistance and grid inductance.
P_{cal}, Q_{cal}	E-STATCOM active and reactive power.
P^*, Q^*	Reference active and reactive power.
U_{dc}	DC-link voltage.
T_s	Sampling time.
ω	Angular frequency of reference frame.
ω_{ci}	Crossover frequency of current loop gain.

I. INTRODUCTION

A. Background and Motivation

All electrical loads connected to a grid generate and absorb reactive power. As the loads typically vary over time with many parameters, the reactive power balance in a grid varies as well. As a result, the voltage variations in the grid may become unacceptably large and even a voltage collapse may occur. STATCOM, a flexible AC transmission system (FACTS) device, is an important technology controlling the reactive power in response to voltage variations, thus supporting the grid stability [1].

STATCOM is a shunt compensator consisting of a coupling transformer and a voltage-source converter (VSC) with a capacitor on its DC side. With the integration of intermittent renewable sources such as PV and Wind power systems into the grid, there is a need to regulate both active as well as reactive power [2]. Thus, STATCOM configured with energy-storage system (E-STATCOM) can provide both active and reactive power support depending on the need and the amount of energy stored in the ESS [1]–[3]. However, injection and absorption of active and reactive power have a transient effect on the DC-link voltage of the E-STATCOM. As a result, decoupling of active and reactive power is necessary to reduce this transient effect and ensure smooth operation of the E-STATCOM.

Typically, an E-STATCOM can provide continuous active and reactive power support. If the grid voltage is higher than the E-STATCOM voltage, the E-STATCOM will absorb reactive power from the grid. On the other hand, if the grid voltage is less than the E-STATCOM voltage, the E-STATCOM will inject reactive power into the grid. Likewise, if the phase difference between the grid voltage and the E-STATCOM voltage is positive, the E-STATCOM will absorb active power from the grid charging the energy storage device.

On the other hand, if the phase difference is negative, the E-STATCOM will inject active power into the grid [1], [4]. It is done so by discharging the energy storage device to supply the load connected into the grid.

B. Relevant Literature

The control of an E-STATCOM is most often realized by controlling the reference current in the dq -frame. However, the presence of cross-coupling between the current components degrades the control performance of the converter since a change in one component affects the other component [5], [6] and the DC-link voltage. This issue is more evident when charging and discharging of the ESS is involved. Moreover, charging or discharging of the ESS adds the AC component to the DC voltage increasing the pulsation in the DC-link voltage [7]. Hence, separating the dq -current components and separately controlling the active and reactive power can significantly improve the operation of an E-STATCOM. Doing so not only improves the voltage control and oscillation damping of the power system [8] but also minimizes the effect of cross-coupling in the DC-link voltage.

An E-STATCOM control technique implementing decoupling of dq -components is presented in [9] to show the effectiveness of the control system based on S-function. However, the result shows high fluctuation in the DC-link voltage. A unified control system based on closed loop decoupled current control is presented in [10] to smoothen the power fluctuations from distributed generation units operating in a microgrid under unbalanced conditions. Similarly, [11] presents a control technique of a multimodular-converter-based E-STATCOM for a high power application to supply active power continuously in conjunction to a wind farm by controlling the reference dq -

current components. Likewise, a combination control scheme for direct compensation current and DC-link voltage is presented in [12] for a faster response. Results in [13] shows that the fuzzy logic PID controller is better than the conventional PI controller implementing decoupled current control. However, the main issue with fuzzy logic PID controller is that the complexity increases with increasing membership functions [14]. Another issue with the fuzzy logic PID controller is that the derivative part of the controller is sensitive to the noises having higher frequency.

C. Contribution and Organization

This paper proposes an application of the novel dq -decoupled control to improve the DC-link voltage regulation of an E-STATCOM. The proposed control method decouples the dq -current component using the reference current produced by the power controller instead of the previously implemented filter inductor current. The proposed control scheme not only improves the dynamic response of the DC-link voltage to step changes in active or reactive power but also improves the active and reactive power regulation.

The remainder of the paper is organized as follows. Section II introduces the theory behind the PQ decoupled control and also presents the proposed PQ decoupled control method. Section III presents experimental evidence based on an E-STATCOM. Finally, section IV concludes the paper.

II. DECOUPLED PQ CONTROL OF E-STATCOM

The overall structure of the E-STATCOM system and its control scheme are shown in Fig. 1. The control mechanism starts by measuring the inverter current and the DC-link voltage and the grid voltage at point of common coupling (PCC). The measured grid voltage provides the reference

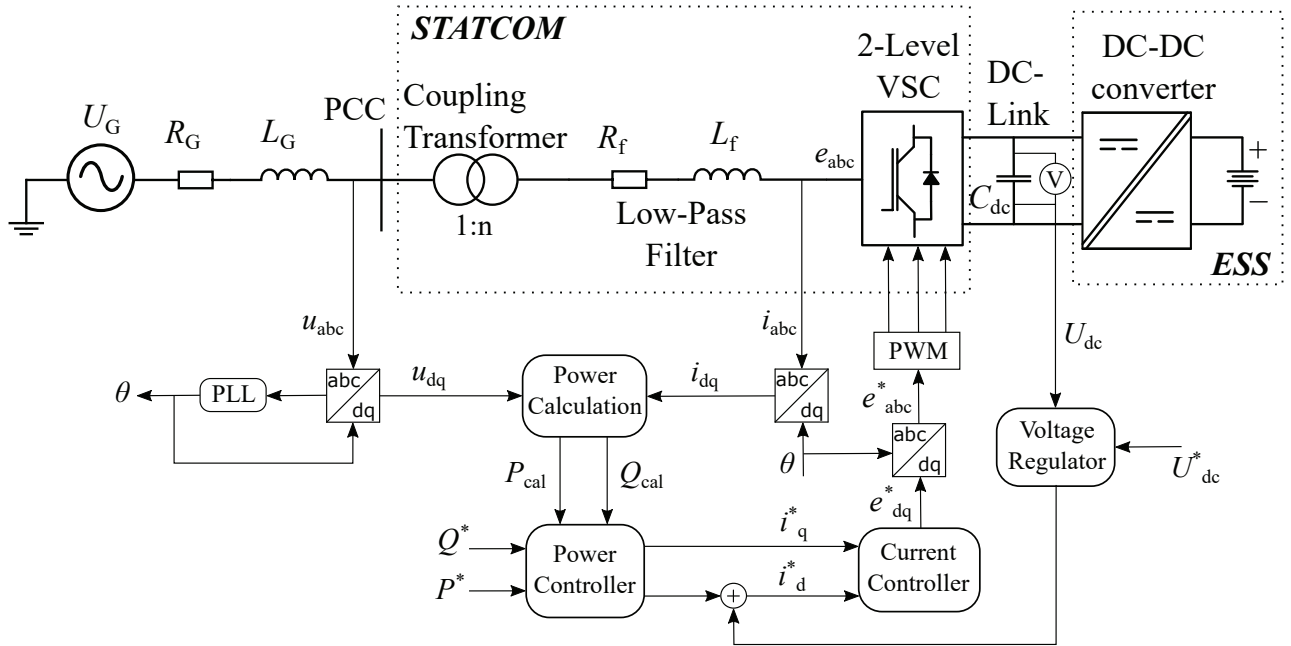

Fig. 1. Structure of an E-STATCOM and its control system.

phase angle for the operation of the VSC with the help of the phase locked loop (PLL). The PLL tracks the frequency and the phase angle of the grid voltage. It also provides the reference phase angle for the abc - $dq0$ as well as the $dq0$ - abc transformation of voltage and current in order to generate the desired switching sequence for the operation of the VSC.

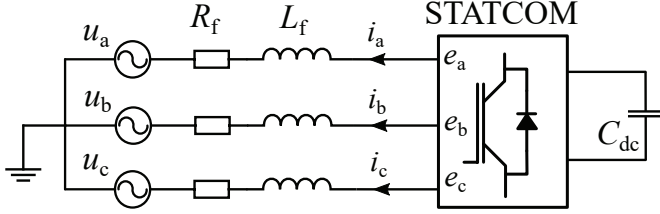

Fig. 2. Simplified STATCOM schematic.

Fig. 2 shows a simplified schematic of a STATCOM with L-type low-pass filter. The dynamic voltage equation for each phase on the AC side of the STATCOM can be derived as

$$\begin{bmatrix} e_a \\ e_b \\ e_c \end{bmatrix} = \begin{bmatrix} u_a \\ u_b \\ u_c \end{bmatrix} + R_f \begin{bmatrix} i_a \\ i_b \\ i_c \end{bmatrix} + L_f \frac{d}{dt} \begin{bmatrix} i_a \\ i_b \\ i_c \end{bmatrix} \quad (1)$$

where e_a , e_b and e_c are the phase voltage of the inverter. Applying Park's transformation, (1) can be written in the dq -frame as

$$\begin{bmatrix} e_d \\ e_q \end{bmatrix} = \begin{bmatrix} u_d \\ u_q \end{bmatrix} + \begin{bmatrix} R_f & -\omega L_f \\ \omega L_f & R_f \end{bmatrix} \begin{bmatrix} i_d \\ i_q \end{bmatrix} + L_f \frac{d}{dt} \begin{bmatrix} i_d \\ i_q \end{bmatrix} \quad (2)$$

It is clear from (2) that the voltage equations are cross-coupled. It is shown in [15], [16] that the decoupled reference inverter voltage can be achieved by decoupling the dq -current components as

$$\begin{bmatrix} e_d^* \\ e_q^* \end{bmatrix} = \begin{bmatrix} \Delta u_d - u_d \\ \Delta u_q - u_q \end{bmatrix} - \omega L_G \begin{bmatrix} i_d \\ i_q \end{bmatrix} \quad (3)$$

Applying inverse Park's transformation to (3) obtains the inverter voltage reference in the abc -frame which produces the PWM signal to operate the inverter. The transformed grid voltage and inverter current in the dq -frame are then used to calculate the active and reactive power as

$$P_{\text{cal}} = \frac{3}{2}(u_d i_d + u_q i_q) \quad (4)$$

$$Q_{\text{cal}} = \frac{3}{2}(u_q i_d - u_d i_q) \quad (5)$$

Evidently, change in one component affects the other component due to the presence of cross coupling between the dq -current components. However, the active and reactive power can be separated by decoupling the currents i_d and i_q , hence enabling the decoupled active and reactive power control of the E-STATCOM as

$$P_{\text{cal}} = \frac{3}{2}|u_{dq}|i_d \quad (6)$$

$$Q_{\text{cal}} = -\frac{3}{2}|u_{dq}|i_q \quad (7)$$

where $|u_{dq}|$ is the voltage magnitude given by

$$|u_{dq}| = \sqrt{u_d^2 + u_q^2} \quad (8)$$

Fig. 3 shows the conventional PQ decoupled control scheme for an E-STATCOM based on [8]. Fig. 3a is the outer power control loop which provides the dq -current reference for the current controller shown in Fig. 3b. In this method, the decoupled active and reactive power control is realized by the decoupled dq -current components which are based on the measured inductor current feedback.

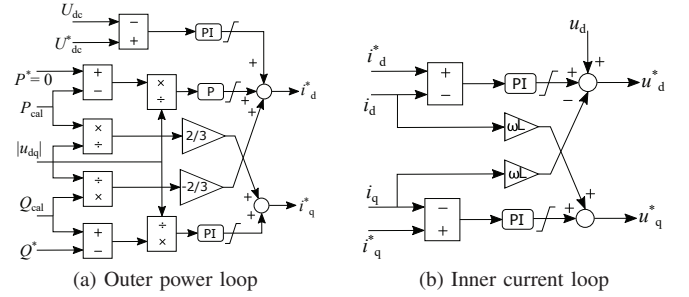

Fig. 3. Conventional control scheme.

The error between the calculated and the reference active and reactive power divided by the voltage magnitude is given to the PI controller of the outer power loop. The output of the PI controller is then compensated for the current component using (4) and (5). Thus, the reactive power regulator generates i_q^* reference current. Likewise, the PI controller of the DC-link voltage regulator along with the P controller of the active power regulator generates i_d^* reference current. The generated i_d^* and i_q^* reference currents are compared to the measured i_d and i_q values and the error is given to the PI controller which generates the inverter reference voltage in the dq -frame.

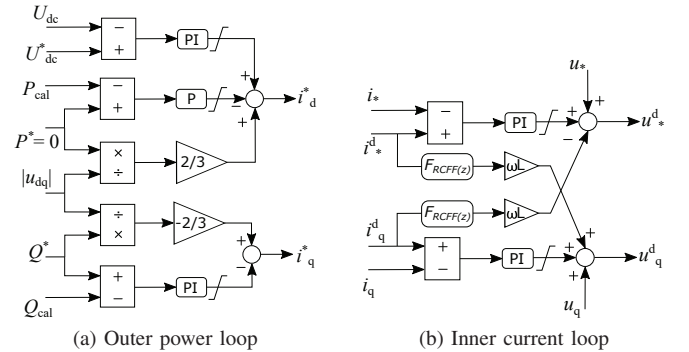

Fig. 4. Proposed control scheme.

In order to reduce the cross-coupling effect and improve the dynamic response of the E-STATCOM, a novel decoupled active and reactive power control is achieved by utilizing the decoupled dq -current control based on the reference current feed forward (RCFF) technique [5]. Fig. 4a shows

the implemented power control technique to generate the E-STATCOM reference current components [17]–[19]. In this method, the error between the calculated reactive power and the reference reactive power is given to the PI controller whose output is added to the current components i_d and i_q calculated using (6) and (7). As a result, the reactive power regulator generates reference current i_q^* and the DC-link voltage regulator together with active power regulator generates reference current i_d^* as shown in Fig. 4a.

Fig. 4b shows the RCFF technique to generate the reference voltage for the E-STATCOM. In this method, the decoupling of current components in the dq -frame is realized by processing the reference current through the compensator $F_{\text{RCFF}}(z)$. A detailed explanation and calculation process of the compensator $F_{\text{RCFF}}(z)$ is presented in [5]. The output of the compensator is added to the output of PI current controller along with the measured grid voltage feedforward terms u_d and u_q as shown in Fig. 4b. The compensator $F_{\text{RCFF}}(z)$ is a second order discrete filter with low pass characteristics defined as

$$F_{\text{RCFF}}(z) = \frac{\omega_{ci} T_s (5 + 4z^{-1} - z^{-2})}{10 - \omega_{ci} T_s + (4\omega_{ci} T_s - 12)z^{-1} + (5\omega_{ci} T_s + 2)z^{-2}} \quad (9)$$

where ω_{ci} is the crossover frequency of the current loop gain that can be approximated as 5% of the sampling frequency f_s , and T_s is the sampling period.

III. EXPERIMENT AND RESULTS

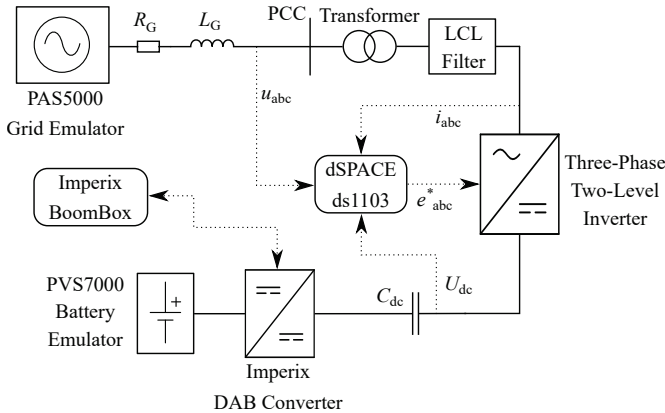

Fig. 5. Experimental setup of the E-STATCOM.

An experimental test setup depicted in Fig. 5 was constructed to demonstrate the effectiveness of the proposed method. For a fair comparison, value of PI controllers were kept same in both conventional and proposed control schemes. The Tektronix TCP312A current measurement probes and the Tektronix P5200 voltage measurement probes were used to measure the inverter current and the PCC voltage, respectively. A Spitzengerber Spies PAS5000 grid emulator was used as the three-phase AC source and a Spitzengerber Spies PVS7000 battery emulator was used as the ESS. The ESS was implemented using a custom-built bi-directional dual active

bridge (DAB) converter. The DAB converter was controlled separately by an Imperix control platform and its control is not discussed in this paper. Additionally, the E-STATCOM was comprised of a 1:1 coupling transformer and a three-phase two-level IGBT based voltage source inverter. The system parameter values are presented in Table I.

TABLE I
COMPONENTS AND SYSTEM PARAMETERS

Grid	
System frequency, f	60 Hz
Nominal power, P_N	10 kW
Grid voltage (rms), U_G	120 V
Grid inductance, L_G	380 μ H
Grid resistance, R_G	0.4 Ω
E-STATCOM	
Inverter power, S_N	7 kW
Battery power, B_N	2.5 kW
DAB converter power, C_N	1 kW
Switching frequency, f_{sw}	8 kHz
Sampling frequency, f_s	8 kHz
Grid side filter inductance, L_{f1}	2.5 mH
VSC side filter inductance, L_{f2}	0.6 mH
Filter resistance, R_f	100 m Ω
Filter capacitance, C_f	10 μ F
Filter damping resistance, r_{cf}	1.8 Ω
DC-link capacitance, C_{dc}	1.5 mF
DC-link voltage, U_{dc}	400 V

Initially, the E-STATCOM is in the equilibrium state where no active or reactive power exchange between the E-STATCOM and the grid is realized. The E-STATCOM was controlled only to provide the reactive power support. On the other hand, the bi-directional DAB converter was used to control the ESS to charge and discharge, providing the chosen active power support through the E-STATCOM.

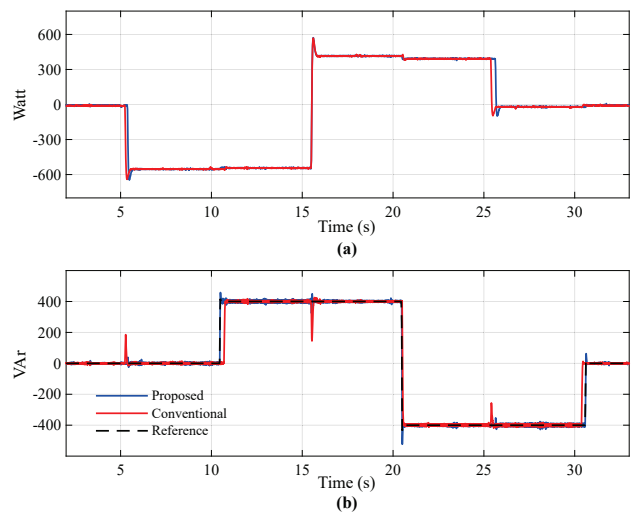

Fig. 6. (a) Active power step change. (b) Reactive power step change

Fig. 6 shows the active and reactive power step change of

the E-STATCOM. At first, the DAB converter was applied to charge the ESS after $t = 5$ s, absorbing nearly 600 Watt active power from the grid. Then, the reactive power reference was given as 400 VAR after $t = 10$ s, providing reactive power to the grid. Next, the DAB converter was applied to discharge the ESS after $t = 15$ s, injecting about 400 Watt active power into the grid. Then, a reactive power reference of -400 VAR was given after $t = 20$ s, absorbing reactive power from the grid. Lastly, the DAB converter was stopped after $t = 25$ s and the E-STATCOM was brought back to equilibrium state after $t = 30$ s.

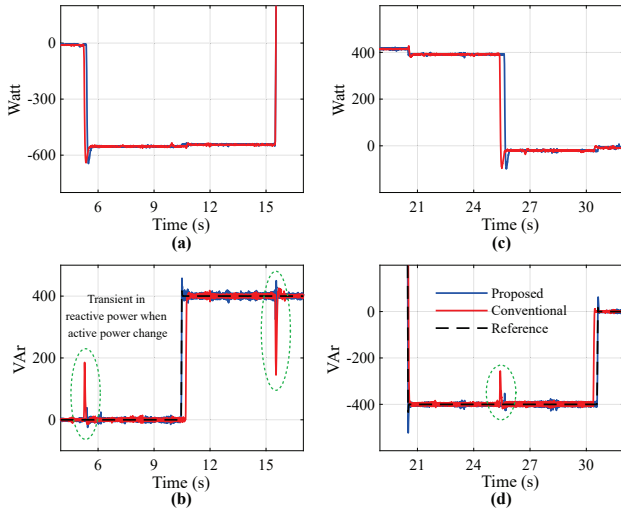

Fig. 7. (a) Active power during ESS charging. (b) Reactive power during ESS charging. (c) Active power during ESS discharging. (d) Reactive power during ESS discharging.

Fig. 7 show the step change response in active and reactive power. Due to the cross-coupling effect, a step change either in active or reactive power has a transient effect to the other component. Hence, the proposed PQ decouple control method attenuates the cross-coupling effect more effectively than the conventional PQ control method. The proposed control scheme successfully reduced the undesired transient effect of active and reactive power step changes to each other significantly in comparison to the conventional control scheme.

Fig. 8 shows the transients in the DC-link voltage for both the conventional and the proposed control method during the step changes in active and reactive power. The effect of the cross-coupling is more noticeable in the case of E-STATCOM facilitating the charging and discharging of the ESS. However, the cross-coupling effect in the DC-link voltage is slightly improved by the proposed decoupled PQ control method. Additionally, Fig. 8 shows that the peak overshoot in the transient of the DC-link voltage caused by the step change in the reactive power during charging and discharging of the ESS are slightly greater in the conventional control scheme when compared to the proposed control method. Furthermore, Fig. 9 shows that the proposed PQ decoupled control method is more effective in minimizing the steady state error in the

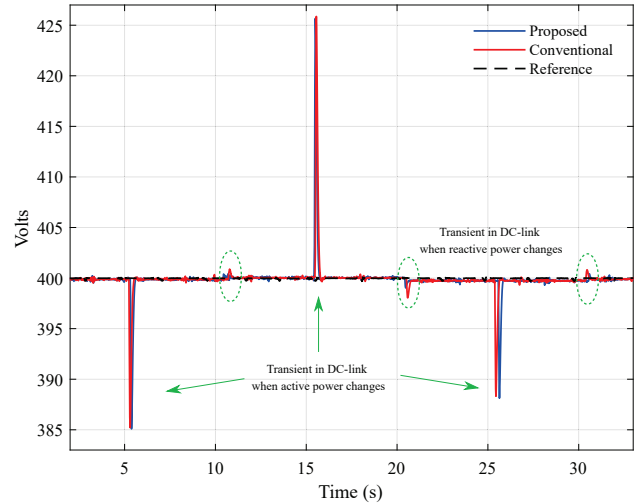

Fig. 8. Effect of active and reactive power step change in the DC-link voltage.

DC-link voltage during both charging and discharging of the ESS in comparison to the conventional PQ decouple control scheme.

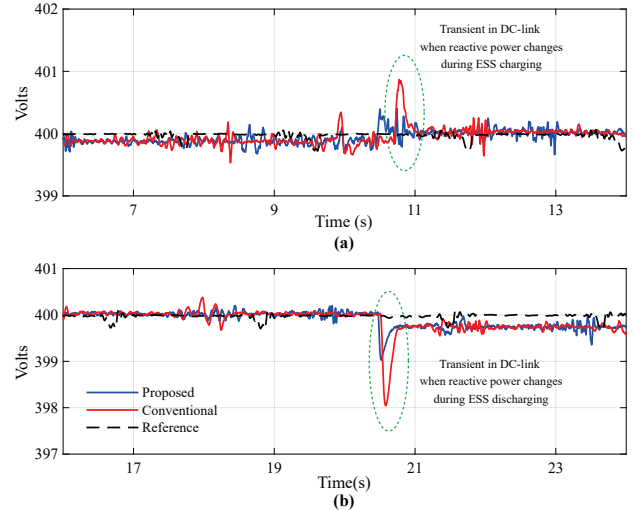

Fig. 9. (a) DC-link voltage during ESS charging. (b) DC-link voltage during ESS discharging.

IV. CONCLUSION

The E-STATCOM is an important FACTS device applied in modern power grids to provide the active and reactive power support thus improving the voltage and the frequency stability. The control of an E-STATCOM is conventionally performed by decoupling the current components using the inductor current feedback. The main drawback of this technique is that the transients in the DC-link voltage during step changes in reactive power in the presence of an ESS are more severe.

This paper has presented an application of the novel control technique in which the active and reactive power are decoupled and separately controlled using the reference current feedforward technique to improve the DC-link voltage dynamics. The proposed decoupled PQ control method significantly minimizes the effects of cross-coupling, reducing the transients in the active and reactive power delivered by the E-STATCOM, ultimately minimizing the cross-coupling effect on the DC-link voltage. The technique also provides more efficient regulation in the DC-link voltage during the steady state operation while charging or discharging the ESS.

A comparison of dynamic response between the conventional PQ decouple control technique and the proposed PQ decouple control technique was presented. The results show that the fast charging and discharging of an ESS connected to an E-STATCOM cause severe transients in active and reactive power as well as in the DC-link voltage which affect the dynamic behavior of the system. As a result, it would be most desired to control the active and reactive power separately to ensure stable and effective operation of the E-STATCOM.

REFERENCES

- [1] E. H. Watanabe, M. Aredes, P. G. Barbosa, F. K. de Araújo Lima, R. F. da Silva Dias, and G. Santos, "Flexible AC transmission systems," *Power Electronics Handbook*, pp. 851–877, 2011.
- [2] L. Naik Popavath, G. Nagaraju, and K. Naresh, "A PV-Statcom for Enhancement of power quality in grid integrated system using Unit Vector Controller," in *Proc. International Conference on Artificial Intelligence and Signal Processing*, pp. 1–6, 2020.
- [3] R. Kuiava, R. A. Ramos, and N. G. Bretas, "Control design of a STATCOM with energy storage system for stability and power quality improvements," in *Proc. IEEE International Conference on Industrial Technology*, pp. 1–6, 2009.
- [4] K. I. Sayahi, A. Kadri, R. Karwi, and F. Bacha, "Study and implementation of a static compensator (STATCOM) using direct power control strategy," in *Proc. International Renewable Energy Congress*, pp. 1–6, 2018.
- [5] S. Zhou, J. Liu, L. Zhou, and Y. Zhang, "DQ Current Control of Voltage Source Converters with a Decoupling Method Based on Preprocessed Reference Current Feed-forward," *IEEE Transactions on Power Electronics*, vol. 32, no. 11, pp. 8904–8921, 2017.
- [6] D. Pan, X. Wang, F. Liu, and R. Shi, "Transient Stability Impact of Reactive Power Control on Grid-Connected Converters," in *Proc. IEEE Energy Conversion Congress and Exposition*, pp. 1–6, 2019.
- [7] Y.-T. Jeon, C. D. Townsend, D. Tafti, E. Rodríguez Ramos, G. G. Farivar, J.-H. Park, and J. Pou, "An Enhanced Static Compensator With DC-Link Voltage Shaping Method; An Enhanced Static Compensator With DC-Link Voltage Shaping Method," *IEEE Transactions on Power Electronics*, vol. 35, no. 3, pp. 2488–2500, 2020.
- [8] Y. Cheng, C. Qian, M. L. Crow, S. Pekarek, and S. Atcitty, "A comparison of diode-clamped and cascaded multilevel converters for a STATCOM with energy storage," *IEEE Transactions on Industrial Electronics*, vol. 53, no. 5, pp. 1512–1521, 2006.
- [9] Z. Chaofan, L. Jian, and C. Junfeng, "Modeling and Simulation Analysis of Energy Storage STATCOM Based on S-Function," in *Proc. International Conference on Intelligent Computing, Automation and Systems*, pp. 146–150, 2021.
- [10] N. R. Merritt, C. Chakraborty, and P. Bajpai, "An E-STATCOM Based Solution for Smoothing Photovoltaic and Wind Power Fluctuations in a Microgrid under Unbalanced Conditions," *IEEE Transactions on Power Systems*, vol. 37, no. 2, pp. 1482–1494, 2022.
- [11] A. Bharadwaj, S. Maiti, N. Dhal, and S. Chakraborty, "Control and sizing of modular multilevel converter-based STATCOM with hybrid energy storage system for large-scale integration of wind farms with the grid," *Electrical Engineering*, vol. 101, no. 3, pp. 743–757, 2019.
- [12] C.-H. Liao and W.-N. Chang, "Combining direct compensation current and DC-link voltage controls in a multilevel cascade STATCOM for fast response requirement," in *Proc. IEEE International Conference on Applied System Invention*, pp. 978–979, 2018.
- [13] A. A. Nafeh, A. Heikal, R. A. El-Sehiemy, and W. A. Salem, "Intelligent fuzzy-based controllers for voltage stability enhancement of AC-DC micro-grid with D-STATCOM," *Alexandria Engineering Journal*, vol. 61, no. 3, pp. 2260–2293, 2022.
- [14] M. F. Hasan and M. A. Sobhan, "Describing Fuzzy Membership Function and Detecting the Outlier by Using Five Number Summary of Data," *American Journal of Computational Mathematics*, vol. 10, no. 03, pp. 410–424, 2020.
- [15] M. R. Chen, H. Wang, G. Q. Zeng, Y. X. Dai, and D. Q. Bi, "Optimal P-Q control of grid-connected inverters in a microgrid based on adaptive population extremal optimization," *Energies*, vol. 11, no. 8, pp. 1–19, 2018.
- [16] M. A. Hassan, M. Y. Worku, and M. A. Abido, "Optimal power control of inverter-based distributed generations in grid-connected microgrid," *Sustainability (Switzerland)*, vol. 11, no. 20, pp. 1–27, 2019.
- [17] H. Hafezi and H. Laaksonen, "Autonomous soft open point control for active distribution network voltage level management," in *Proc. IEEE Milan PowerTech*, pp. 1–6, 2019.
- [18] C. Shen, Z. Yang, M. L. Crow, and S. Atcitty, "Control of STATCOM with energy storage device," in *Proc. IEEE Power Engineering Society*, vol. 4, pp. 2722–2728, 2000.
- [19] S. M. Tripathi and P. J. Barnawal, "Design and Control of a STATCOM for Non-Linear Load Compensation: A Simple Approach," *Electrical, Control and Communication Engineering*, vol. 14, no. 2, pp. 172–184, 2018.