

EXPERIMENTAL EVALUATION OF A DIGITAL HYDRAULIC POWER MANAGEMENT SYSTEM

M. Sc. Mikko Heikkilä, M. Sc. Jyrki Tammisto, M. Sc. Mikko Huova,
Prof. Kalevi Huhtala, Adj. Prof. Matti Linjama
Tampere University of Technology
Department of Intelligent Hydraulics and Automation
P.O. BOX 589
FI-33101 Tampere, Finland

ABSTRACT

The digital hydraulic power management system is a new energy-efficient alternative to the fluid power system. Based on digital (stroke to stroke) control of each piston of the pumping unit, its functionality consisted of (1) an arbitrary number of independent outlets, (2) service of each outlet at arbitrary pressure levels, (3) energy recovery from each outlet back to the prime mover, (4) power transfer from one outlet to another at arbitrary pressure levels, and (5) energy storage in and recovery from a hydraulic accumulator independent of pressure. Theoretical analysis and simulations show that the principle works and is highly efficient. This paper reports experimental results on the principle. The prototype power management system consisted of a six-piston boxer pump, fast on/off control valves, and two independent outlets. The system was measured for its efficiency, controllability and energy transformation functionality. The results are encouraging but show also that more pistons are needed for smooth flow rates. In addition, control methods need to be further developed for more accurate pressure control.

KEYWORDS: Digital hydraulic power management system, efficiency, pump, motor, transformer, independent outlets

1. INTRODUCTION

This paper is partly based on the publication [1] and is reproduced with permission of Centre for Power Transmission and Motion Control, University of Bath.

The digital hydraulic power management system (DHPMS) presented is a solution based on digital pump-motor technology, in which Artemis Intelligent Power Ltd. is the leading pioneer [2]. Like traditional pumps, this digital technology uses reciprocating pump elements with the exception that the check valves or the valve plate are replaced with active on/off control valves.

An important difference between digital and traditional pump technology is programmability. In the former, the operating mode of each piston can be selected independently of each other. In addition, the pre-compression can be optimized according to the load pressure without compromises. Valve delays can be compensated for, which is not possible with passive check valves. Moreover, the pressure release function allows recovery of the energy stored in the compressibility of the fluid. The main drawback is that the flow rate fluctuates considerably at partial displacement [3]. Another challenge is that the technology sets high requirements for the durability, flow capacity, and accuracy of the control valves. And, of course, digital machines are also more difficult to control because they come with more control options.

The concept and theoretical study of the DHPMS have been published before [4]. The idea behind the concept is to multiply control valves (a simple digital hydraulic power management system is shown in figure 1). Additional valves are introduced between the pumping chambers and the new outlet B. If the pre-compression and pressure release phases are ignored each piston then having six modes:

- Pump into outlet A (Pump A)
- Pump into outlet B (Pump B)
- Pump into tank (Pump T)
- Receive fluid from outlet A (Motor A)
- Receive fluid from outlet B (Motor B)
- Suck fluid from tank (Suck T)

Neither the number of independent outlets nor the pressure at the outlets has to be limited, because each piston is connected to exactly one outlet or to the tank. Thus the DHPMS in figure 1 can serve two actuators with arbitrary pressure levels and flow direction. The digital hydraulic power management system can also be implemented by using fixed displacement pump-motor units instead of pistons [5].

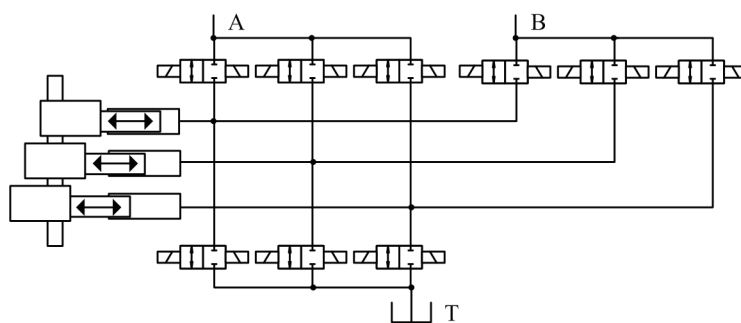

Figure 1. Simple digital hydraulic power management system

This paper reports experimental results on a prototype digital hydraulic power management system. The studied system consisted of a six-piston boxer pump equipped with fast prototype valves and two independent outlets, and was measured for its efficiency and controllability. Furthermore, the system's capability to transfer power between actuator lines was examined.

2. CONTROL METHOD

2.1. Selection of operation mode

The studied six-piston boxer pump had three piston pairs, and in each pair the pistons were in opposite phases, resulting in six working mode decision instants during one pump revolution. At each mode decision instant, pumping mode was chosen for one piston and suction mode for the other.

The above mode choice was to keep the actuator supply pressure within user-given threshold values, as shown in figure 2. Both pumping mode and suction mode are chosen to the tank line whenever the pressures are within threshold values at a mode choice instant (instants 1, 2, 3 and 10 in the figure). In the case that the pressure in one actuator supply line is outside threshold values and within in the other, mode choice is straightforward as shown in the figure (instants 5, 7, 8, 9). At the fourth mode choice instant in the figure the pressure in the line A is too low and in the line B too high. Therefore the pumping piston connects to the actuator line A and in the suction phase to the line B. If both pressures are too low, as they are during the sixth mode choice instant in the figure, the pumping piston connects to the line with the highest undershoot. The motoring mode is chosen in the same way if both pressures are too high.

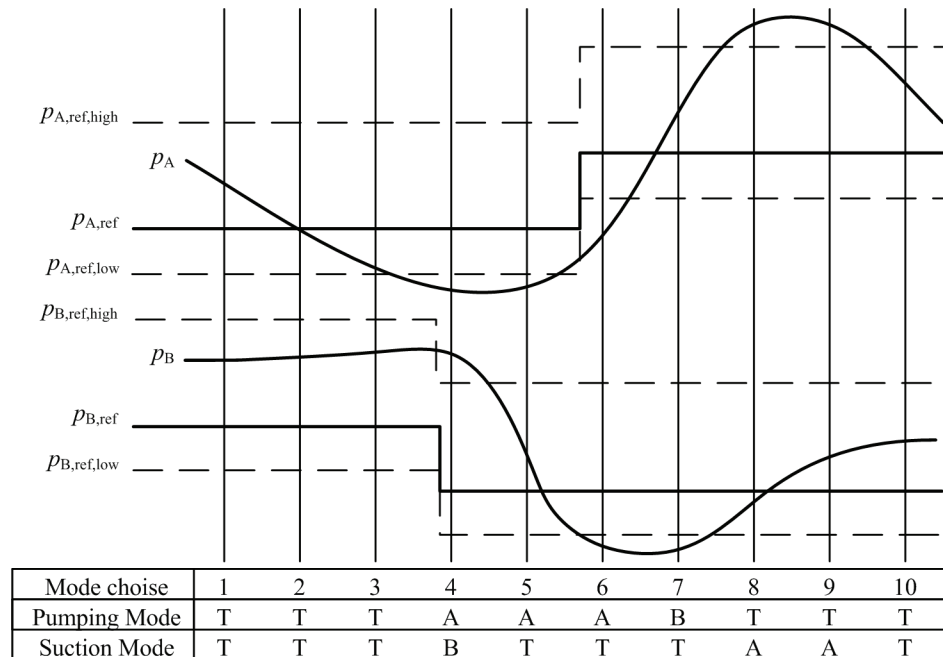

Figure 2. Examples of selecting the operation modes.

2.2. Control of valve timing

To operate smoothly, the DHPMS must accurately time the valve switching. To avoid excessive pressure peaks and oscillation, pressures at valve inlet and outlet ports must be close in value when the valve opens. Incorrect valve timing lowers efficiency as well. Therefore, pre-compression time, pressure release time, and valve delays must all be taken into account in valve control.

The valve timing principle of pump and motor modes is shown in figure 3. A single piston is considered and x is the piston position, u_A and u_T the control signals and p the chamber pressure. The work cycle of pump mode starts at the bottom dead center (BDC) where the T-valve (low pressure) closes and the pre-compression is followed. The A-valve (high pressure) opens when the chamber pressure is increased sufficiently and pumping starts. The pumping stroke ends at the top dead center (TDC) where the A-valve closes. The chamber pressure is then released before the T-valve opens and the suction stroke continues until the T-valve closes at the BDC and a new cycle starts.

The work cycle of motor mode starts with pumping into low pressure after the T-valve opens at the BDC. The chamber pressure is raised at the end of the pumping stroke by closing the T-valve before the TDC where the A-valve opens and the motoring starts. The chamber pressure is released at the end of the motoring stroke by closing the A-valve before the BDC until a new cycle starts. Evidently, pre-compression and pressure release can be optimized regardless of pressure levels and operating modes. Valve delays can also be compensated for as shown in figure 3.

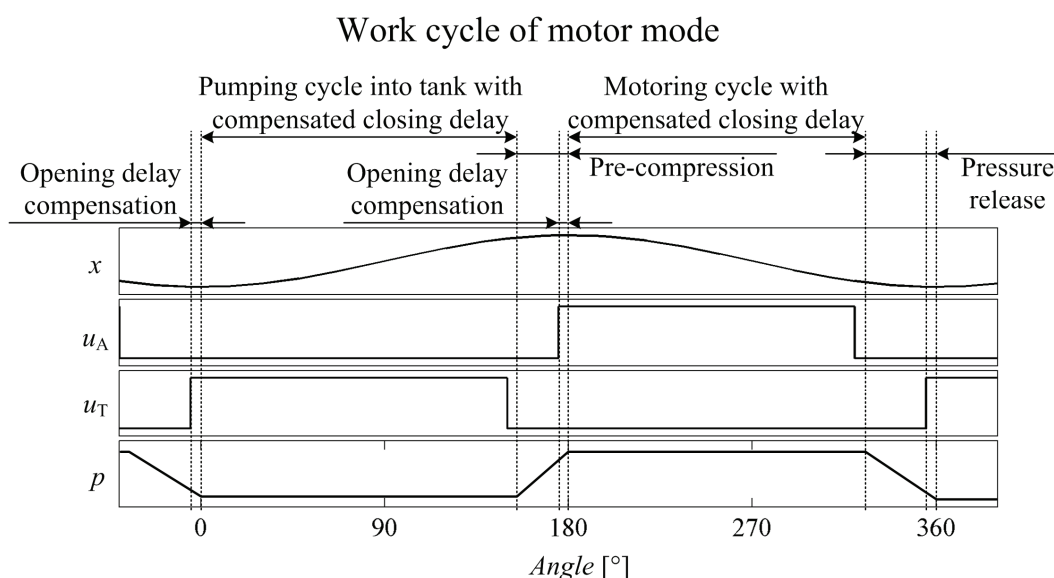
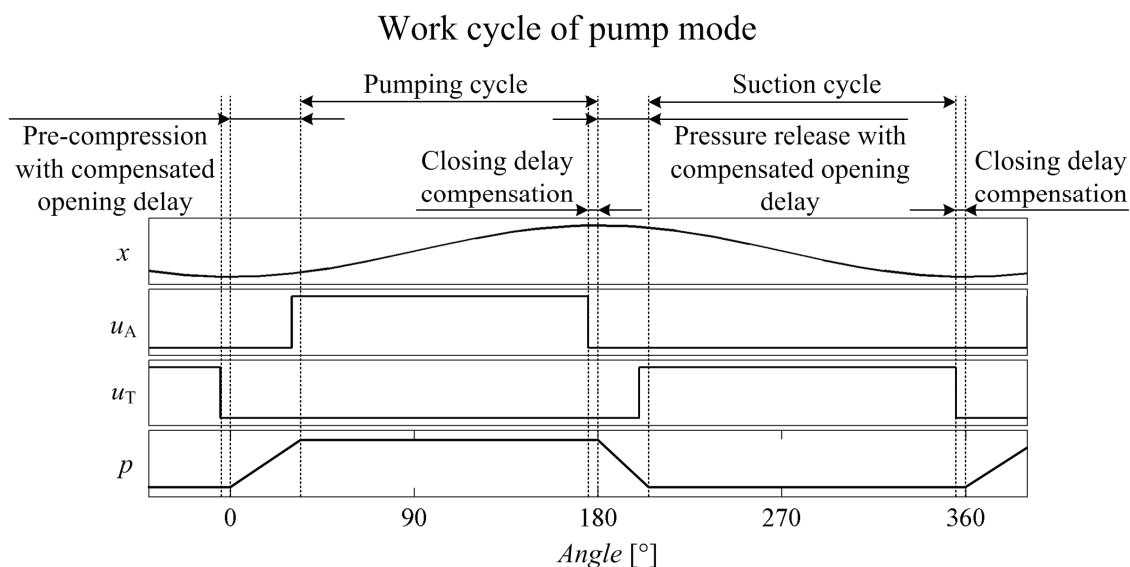

Figure 3. Pump and motor mode valve timing diagrams of the single piston

The valves are always controlled based on a measured piston angle, and a valve command is executed when the piston angle reaches the optimal calculated switching angle. The absolute rotation angle of the pump axis was measured by using a Hall sensor and a 144-tooth gear ring in the system. In addition, a separate zero pulse was applied to avoid the cumulative measurement error. With applied filtering the absolute error of the angle estimate was less than 0.1 degrees.

3. TEST SYSTEM

3.1. Pump modification

The digital hydraulic power management system was modified from a six-piston boxer pump by replacing the check valves with actively controlled, fast two-way prototype on/off valves. Their opening and closing delays were about 1 ms and their flow rate about 23 l/min at a 5-bar pressure difference. The modified pump unit is shown in figure 4.

Each cylinder had a tank valve, two actuator valves, and a pressure relief valve, and pressure was measured in each cylinder. The tank line had two accumulators and was constructed with low pressure hoses to minimise pressure oscillation. Tank and both actuator line pressures and temperatures were measured from the valve blocks.

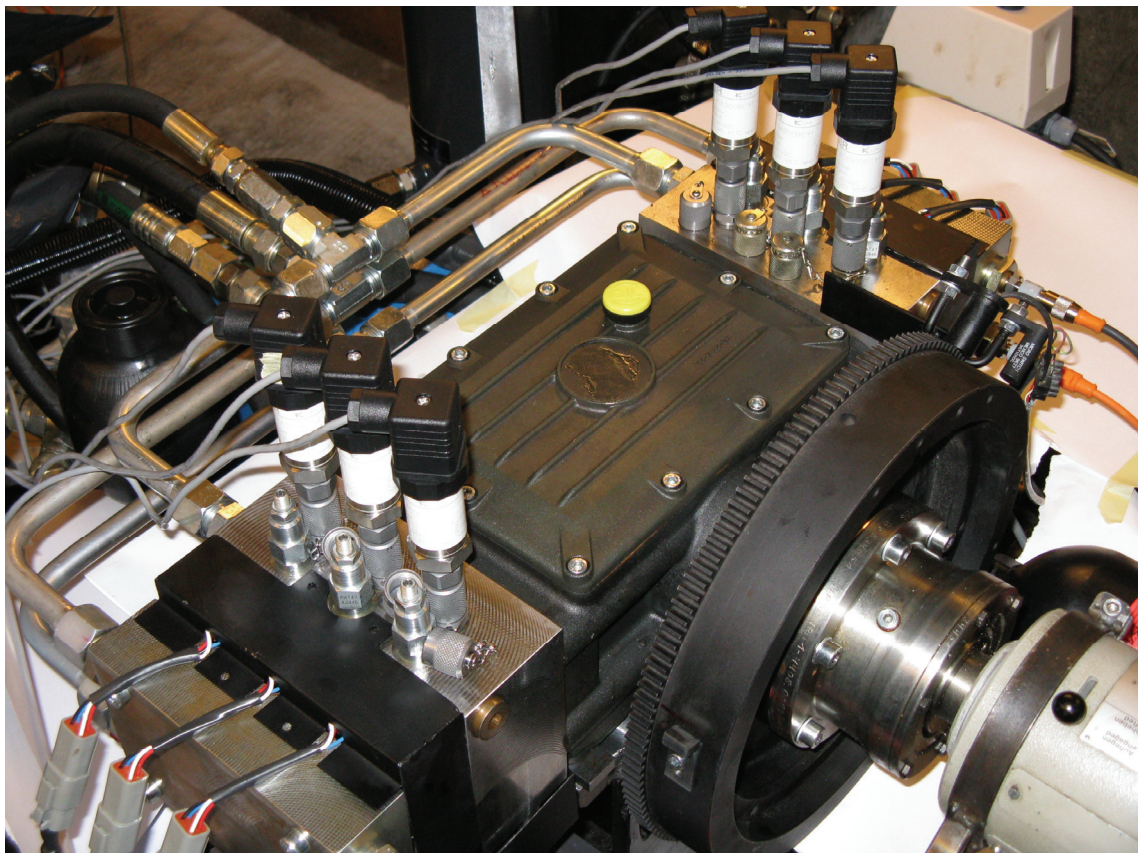

Figure 4. Modified pump unit (DHPMS)

3.2. Measurement system

Figure 5 shows the measurement system of the digital hydraulic power management system, marked with an oval next to the torque sensor. Both actuator lines (A and B) had flow and pressure sensors near the accumulators.

The flow in actuator line A was measured after the accumulator, whereas that in line B was measured before the accumulator. The accumulator in actuator line A was 0.75 litres and was used to smooth flow and pressure oscillations. Line B had a 4-litre accumulator, which was used for energy storage. Both accumulators could be switched off the circuit. Pressure responses were also measured using a 10-litre rigid volume in the circuit instead of 0.75-litre accumulator. Different loadings were realised using an electrically controlled proportional directional control valve in line A and a manual throttle valve in line B. For safety reasons, pressure relief valves were mounted on the actuator lines.

Because the flow capacity of the on/off valves was less than that of the original check valves, a pressurized tank line was used to avoid cavitation in the modified pump unit. Therefore, an auxiliary pump had to be used. The inlet pressure was about 10 bar and was controlled with a pressure relief valve.

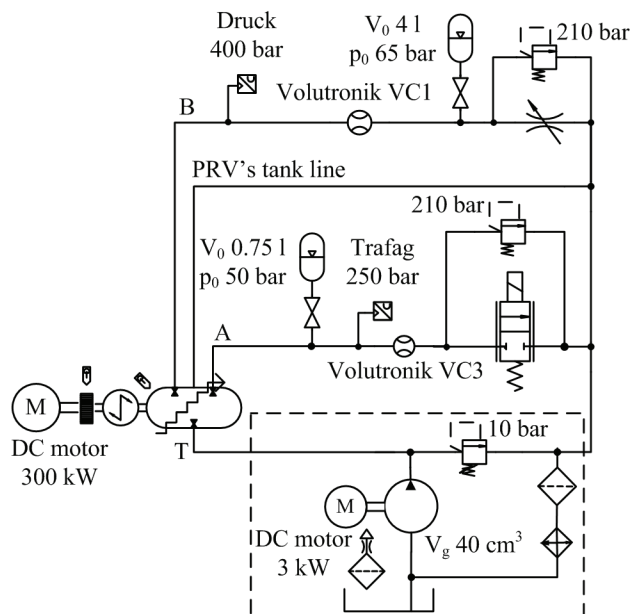

Figure 5. Measurement system of the DHPMS

4. EXPERIMENTAL RESULTS

4.1. Efficiency measurements

Pumping efficiency at full displacement was measured at 500, 750, and 1000 rpm angular velocities without the actuator line accumulator. The oil temperature was about 40 °C, and the pressure differences applied were 20 to 180 bar.

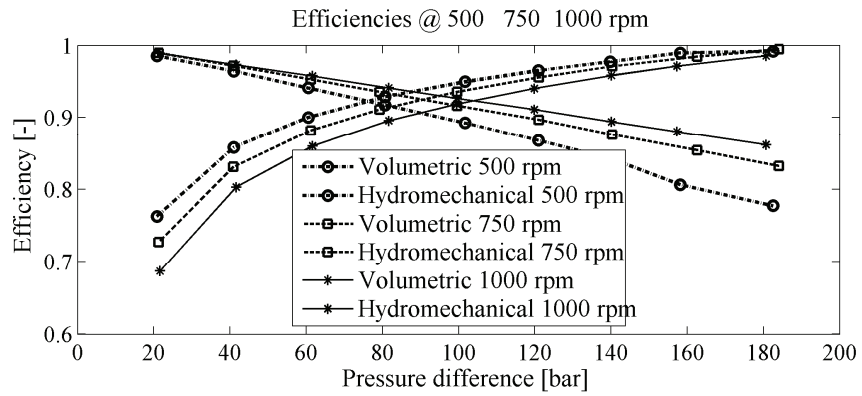

Figure 6. Volumetric and hydromechanical efficiencies of the DHPMS as pump at full displacement

Volumetric and hydromechanical efficiencies are shown in figure 6. The volumetric efficiency clearly dropped when the pressure difference was increased, mainly because of leaks in the on/off valves. Hence the volumetric efficiency increased along with the angular velocity.

The hydromechanical efficiency was high but dropped when the angular velocity was increased mainly because of the low flow capacity of the on-off valves. Increasing the pressure difference improved the hydromechanical efficiency.

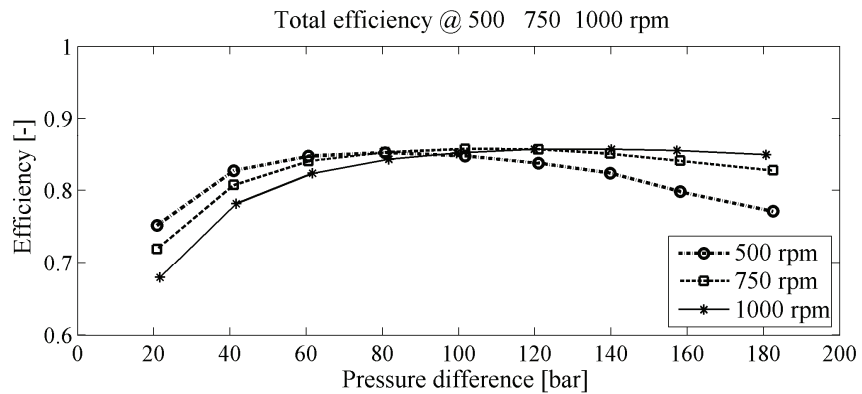

Figure 7. Total efficiencies of the DHPMS as pump at full displacement

Total efficiencies are shown in figure 7. The system's total efficiency was low at low pressures when the angular velocity was increased, whereas at high pressures it increased with increasing angular velocity. The total efficiency was 80 % over most of the measurement range.

Total efficiencies with partial displacements are shown in figure 8. An angular velocity of 500 rpm and an oil temperature of 30 °C were used. The actuator line accumulator was used to smooth the flow.

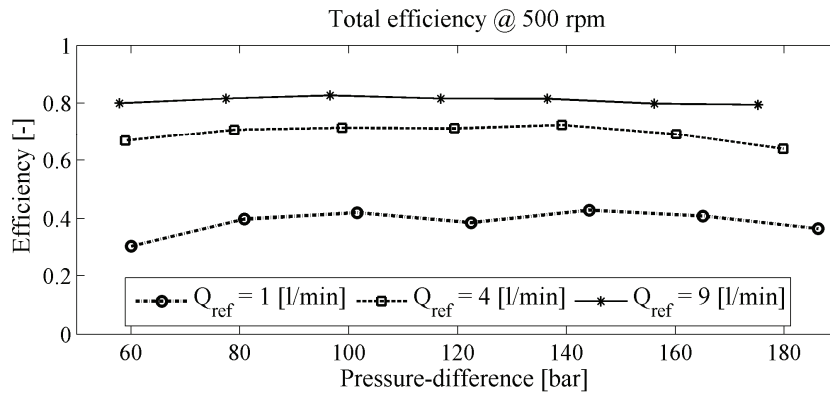

Figure 8. Total efficiencies of the DHPMS as pump at partial displacements

The total efficiency dropped when flow was decreased. At flows over 4 l/min, the efficiency was almost consistently above 70 %, whereas at small flow, it was poor owing to idle losses of the DHPMS.

The efficiencies of the digital hydraulic power management system were also measured as motor (figure 9). An angular velocity of 500 rpm and an oil temperature of 30 °C were used and the measurements were done on actuator line B with the accumulator engaged. The pressure in the accumulator was raised to its maximum, and the pressure reference then changed to 60 bar. Since the reference was lower than the measured pressure in the actuator line, motoring started. Efficiencies were calculated at designated times to obtain efficiency at a certain pressure difference. The accumulator pre-charge pressure was about 65 bar, yielding a minimum pressure difference of 60 bar. The maximum pressure difference measured 150 bar.

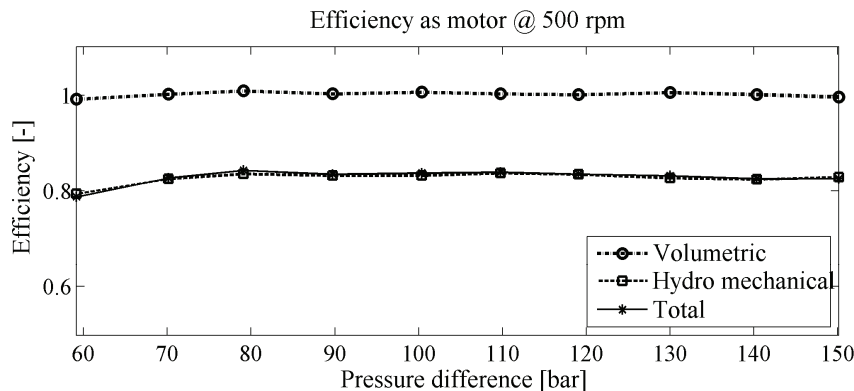

Figure 9. Efficiencies of the DHPMS as motor at full displacement

Because the volumetric efficiency was defined as the ratio of the motor geometrical volume and the measured flow into the motor multiplied by angular velocity, it was at best slightly over 100 %. At a motoring stroke, the pressure valve was closed before BDC (pressure release), and therefore the motor sucked oil from the actuator line less than the geometric volume. The hydromechanical efficiency was over 80 % over most of the pressure range. At some points (for instance 80 bar), the total efficiency was better than the hydromechanical efficiency, because the volumetric efficiency was over 100 %.

4.2. Idle losses

Idle losses signify the power the DHPMS consumed while idling, and they are shown at different angular velocities in figure 10. An inlet pressure of 10 bar and a temperature of 40 °C was used and idle losses at 200 to 1400 rpm angular velocity were measured.

Idle losses increased rapidly when the angular velocity was increased mainly because of increased pressure losses in the on/off valves. The idle losses fit well the third order fitting curve.

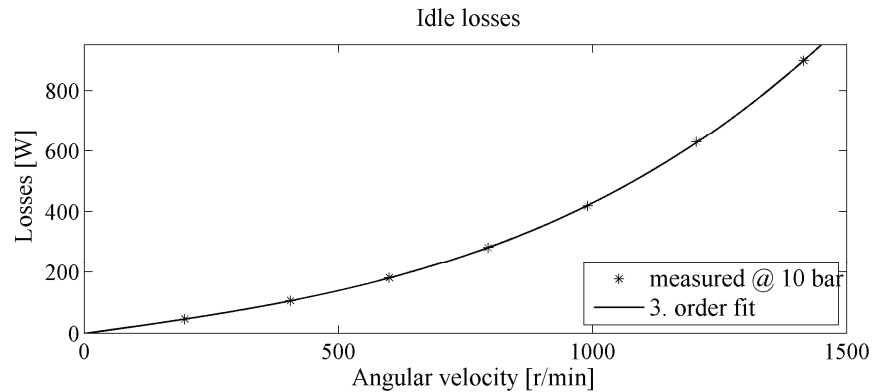

Figure 10. Idle losses of the DHPMS at different angular velocities

4.3. Pressure response

Pressure responses with different actuator flows are shown in figure 11. An angular velocity of 500 rpm, a temperature of 30 °C, and a step of 70 to 100 bar were used. Responses were measured on actuator line A with the accumulator engaged. The flow out of the accumulator was controlled with a proportional valve. Before a pressure step, flows were set at zero, 3 l/min, and 7 l/min.

When the flow out of the accumulator was increased, pressure rose more slowly. Because the start of the step was not fixed at any particular angle, initial pressures varied slightly at the step time. In addition, the system pressure dropped more rapidly with bigger flows.

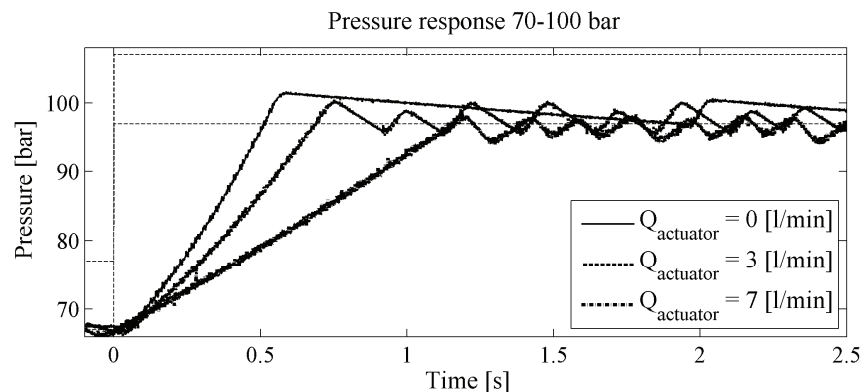

Figure 11. Pressure response with different actuator flows at an angular velocity of 500 rpm

The effect of the pressure level on the pressure step upwards with the accumulator engaged is shown in figure 12, while the pressure step downward is shown in figure 13. Various pressure steps were tested because of the non-linearity of the gas accumulator. An angular velocity of 500 rpm and a temperature of 30 °C were used. The proportional valve was kept closed.

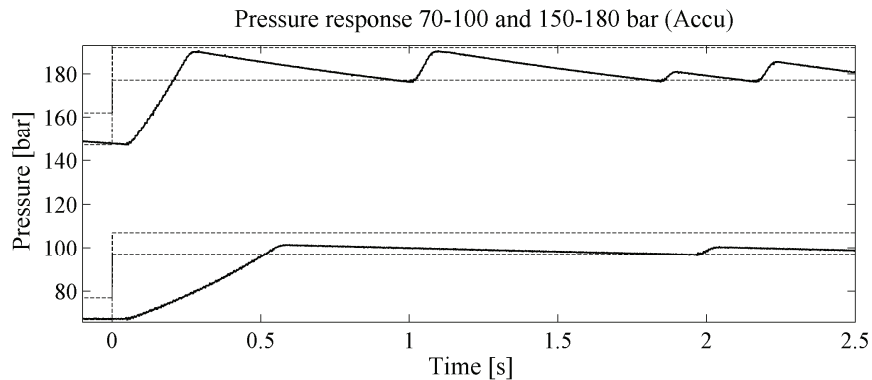

Figure 12. Pressure responses (step up) at different pressure levels at 500 rpm angular velocity when the accumulator is used

A pressure step of 30 bar from 70 and 150 bar is shown in figure 12. Because the pressure increased much faster at higher pressure, wider thresholds had to be used. The pressure also varied widely. Three different overshoots occurred in step response from 150 to 180 bar, as the controller engaged the pump each time the system pressure dropped below the lower reference limit. The controller could have used one, two, or three strokes depending on the measured system pressures. Moreover, pumping occurred more often at high pressure because of increased leakage and a smaller gas volume in the accumulator.

Lowering the pressure was executed by motoring. Pressure steps from 180 to 150 bar and 100 to 70 bar are shown in figure 13. The responses downward were slightly faster owing to leaks in on/off valves. Noteworthy is that at the higher pressure level leaks caused the actuator line pressure to decrease more rapidly, hence the controller had also decided to pump at the end of the measurement in order to keep the pressure within reference values.

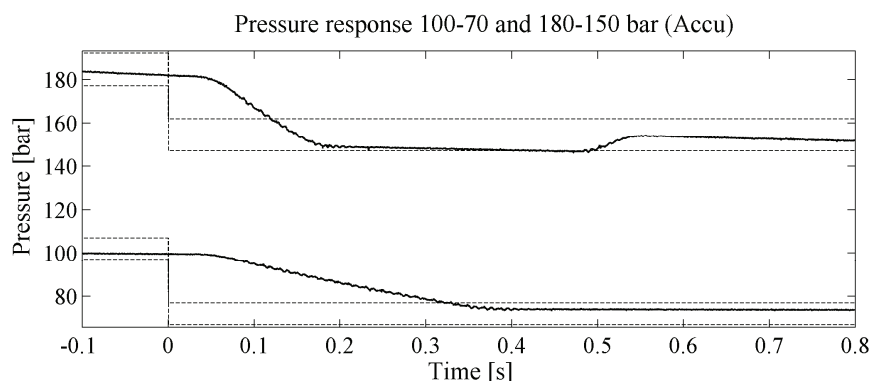

Figure 13. Pressure responses (step down) at different pressure levels at 500 rpm angular velocity when the accumulator is used

Figure 14 shows the pressure steps from 20 to 50 bar and 150 to 180 when the accumulator in the actuator line A was replaced with the 10-litre rigid volume. An angular velocity of 500 rpm and a temperature of 30 °C were used. The flow out of the volume was zero i.e. the proportional valve was closed. It is evident that the pressure raise was much more linear when compared to that in the case of the gas accumulator. The rigid volume can also be used in wider pressure range than the gas accumulator.

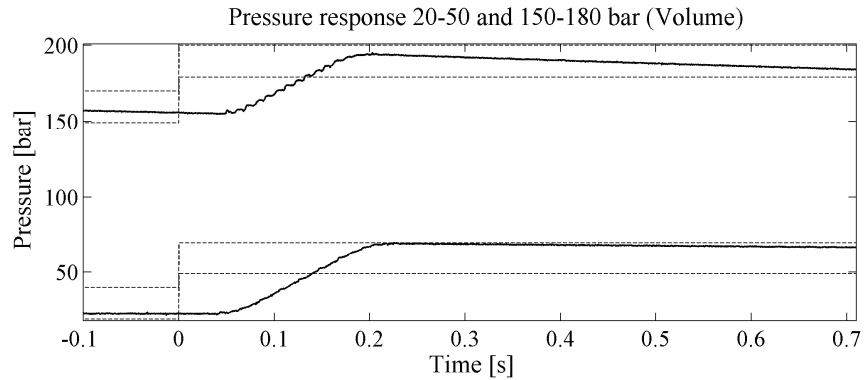

Figure 14. Pressure responses at different pressure levels at 500 rpm angular velocity when the rigid volume is used

4.4. Response to flow disturbance

Besides pressure response, also response to flow disturbance was measured. A disturbance was produced with a proportional valve in actuator line A, and the controller sought to maintain constant pressure. When the proportional valve opening was increased, flow out of the accumulator increased, simulating an actuator with increasing speed (response shown in figure 15). An angular velocity of 500 rpm, a temperature of 30 °C, and a 0.75-litre accumulator were used.

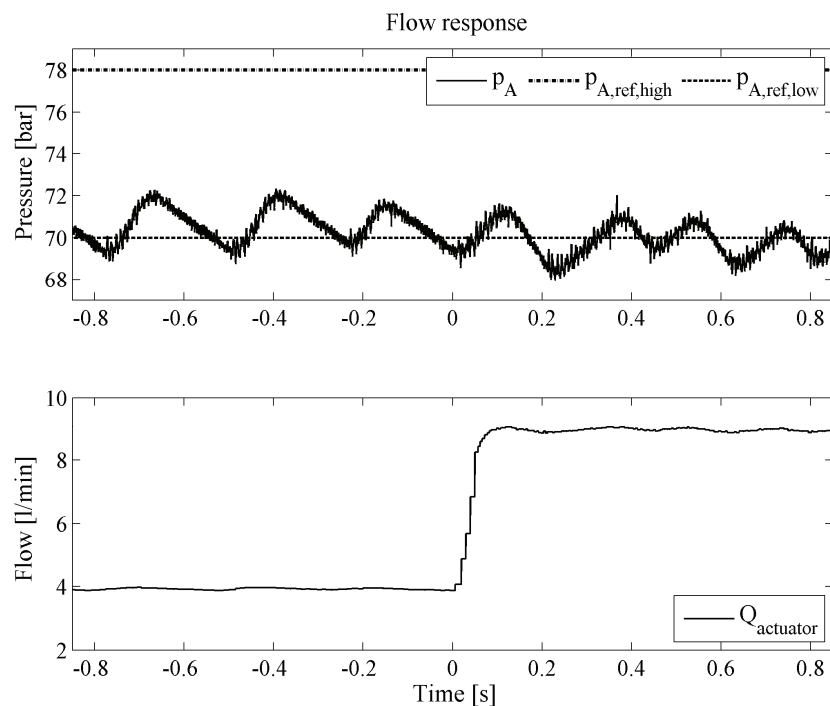

Figure 15. Response to flow disturbance

The flow out of the accumulator increased as the proportional valve opening was increased. Because of increased flow, pressure in the actuator line dropped rapidly, and pumping strokes became more frequent. However, the pressure did not significantly change even at changing flow.

4.5. Power transfer

Power transfer was studied with fluid being received from actuator line B and pumped to actuator line A, accomplished by charging the accumulator in line B to 150 bar and then applying reference steps. The reference for actuator line A was changed from 1 to 100 bar, while concurrently that for line B was changed from 150 to 70 bar.

The above power transfer is shown in figure 16 with actuator pressures in the upper part of the figure and below that flows in the actuator lines. An angular velocity of 500 rpm and a temperature of 30 °C were used. The proportional valve in actuator line A was open to maintain a pressure of less than 100 bar at full displacement. The throttle valve in actuator line B was closed.

After the steps, pumping strokes were executed in actuator line A and suction strokes from actuator line B; that is, fluid was received from line B and pumped into line A. It should be noted that pumping and motoring take place in parallel at full displacement. The hydraulic power taken from actuator line B was about 2.61 kW and that pumped into line A was 1.67 kW. In addition, the shaft power transferred to the electric motor was about 0.43 kW. Hence losses were about 0.51 kW (2.61-1.67-0.43) and the efficiency of power transfer 80 %. Powers were defined from 0.1 seconds to the end of the measurement, that is, at full displacement.

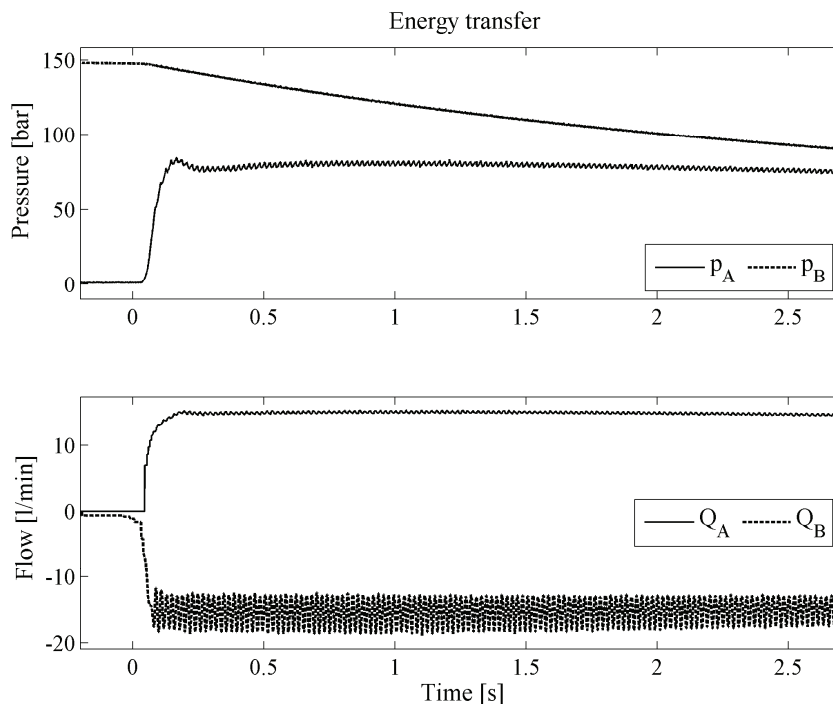

Figure 16. Power transfer between actuator lines

5. CONCLUSIONS

The results prove that the digital hydraulic power management system works both as pump and motor. Moreover, it is capable of transferring power between actuator lines. Because pressures can differ at outlets, the DHPMS executes a hydraulic transformer function as well. The power transfer efficiency of the system was 80 %. Consequently, its efficiency did not decrease in the transformer mode.

Total efficiencies were between 65 and 85 % when pumping at full displacement. At partial displacements, they were lower due to idle losses in the system. At full displacement motoring, total efficiencies were 80 to 85 %. At some points, the volumetric efficiency was even beyond 100 %, owing to the definition of the term. It would have been even better if the valves had leaked less.

Response measurements show that pressures in actuator lines could be controlled even if actuator flows changed. It took 0.25 to 0.5 seconds for pressure in the actuator line to rise 30 bar when the 0.75-litre accumulator was used, for pressurising time depends on pressure level. Lowering the pressure occurred a bit more rapidly.

For pressure control, nonlinearity is an undesirable feature in accumulators, and a rigid volume will be the better option. When the 10-litre volume was used it took about 0.15 seconds for pressure to raise 30 bar regardless of pressure level. However, more advanced control methods should be considered in order to achieve more accurate pressure control. For example, an accumulator model added to the controller would make for more accurate pressure control.

Electrical losses in valves were not included in this research because of the prototype valves used. However, the DHPMS should consume electrical power no more than a few percent of its maximum power, which is challenging for existing valve technology.

In summary, this first prototype digital hydraulic power management system was not as efficient as traditional machines mainly because of the prototype valves used in it. However, the results show that the fluid power system's efficiency can be significantly improved by using the DHPMS approach because of its extended functionality.

REFERENCES

- [1] Heikkilä, M., Tammisto, J., Huova, M., Huhtala, K., Linjama, M. Experimental Evaluation of a Piston-Type Digital Pump-Motor-Transformer with Two Independent Outlets. Bath/ASME Symposium on Fluid Power and Motion Control FPMC 2010, Bath, United Kingdom, 2010.
- [2] Ehsan, Md., Rampen, W., Salter, S. Modeling of Digital-Displacement Pump-Motors and Their Application as Hydraulic Drives for Nonuniform Loads. ASME Journal of Dynamic Systems, Measurement, and Control, March 2000, Vol. 122, pp. 210 – 215.

- [3] Tammisto, J., Huova, M., Heikkilä, M., Linjama, M., Huhtala, K. Measured Characteristics of an In-line Pump with Independently Controlled Pistons. The 7th International Fluid Power Conference, IFK'10, Aachen, Germany, 2010.
- [4] Linjama, M., Huhtala, K. Digital Pump-Motor with Independent Outlets. The 11th Scandinavian International Conference on Fluid Power, SICFP'09, Linköping, Sweden, 2009.
- [5] Linjama, M., Tammisto, J. New Alternative for Digital Pump-Motor-Transformer. The Second Workshop on Digital Fluid Power, DFP'09, Linz, Austria, 2009.