

**AMIR BALDARI**

**PRINTED RESISTIVE NFC SENSOR  
FOR ON SKIN APPLICATION**

**FACULTY OF ELECTRICAL COMMUNICATION AND ELECTRONIC  
MASTER THESIS  
SEPTEMBER 2019**

## ABSTRACT

Amir Baldari: MSc in Electrical Engineering  
Master thesis  
Tampere University  
Department of Electrical Communication and Electronic Engineering  
Examiners: Professor Matti Mäntysalo, Professor Donald Lupo  
September 2019

---

Modern advances in electronic circuit and device invention are rapidly organizing the foundations for health and human measuring body sensors monitoring technologies that have stretchable printed skin properties with availability of on-skin sensors. This field of technology can use Near Field Communication (NFC) standard with capability to transfer high data rate and harvesting energy. Comfortable and wearable sensing and measuring devices are required to permit continuously monitoring and logging of a person's health; furthermore, other important considerations that should be implemented in design of this kind of technology fabricates the cheap and flexible components.

Technically, magnetic field inductive coupling domain and near-field communication (NFC) schemes deliver energy to printable sensor and reading the actual values from the chip. However, most of the examples are emerging and existing classes of devices that require wired connections and batteries to enable reading data operation.

The principal purpose of this thesis is laying out, implementing and testing practical systems for NFC based sensor by capability of connect to external analogue input such as resistance with NFC readers like smartphones. It is presented, the multiple sensors monitoring with different physiological parameters such as resistive printed flexible on body sensor can be linked simultaneously to NHS3152 tag fabricated by NXP and availability to access last updated recorded value of sensors continuously from NFC readers. Subsequently, to program the chip with C programming language and written by NFC Data Exchange Format (NDEF) message, the LPCXpresso software has been used to connect the LPC-Link 2 debugger kit and transfer data from computer to NHS3152 chip and flash the chip by Flash magic program.

At the beginning of practical part and for testing the system, NHS3152 internal temperature sensor was programmed and the actual ambient temperature has been recorded in fully passive loop by NFC TagInfo and the result was satisfying with comparing to external existing temperature sensor.

Many ways have been tested to reach optimized point of resistance measurements and finally, the best result is depicted in Wheatstone bridge by reference voltage circuit that measured values are considerably accurate in linear region by sensitivity close to 0.26 and accuracy rate of 1.35% (for 10 k $\Omega$  device under test). At the end, the analysing of screen-printed stretchable carbon interconnects with designed resistance circuit by reference voltage (Wheatstone bridge) based on NFC NHS3152 is considered. The results show that the sensor by minimum length of 15-20 (4.5-6 k $\Omega$ ) could be measured by stretching to 20 k $\Omega$  dynamic range.

## **PREFACE**

This thesis is made as a completion of the master education in Electrical engineering department of Tampere University.

I would like to thank my examiners Professor Matti Mäntysalo and Professor Donald Lupo for being helpful and supportive during the implementation period of master thesis in Tampere University.

This work owes a lot to the cheerful appreciation of my family members to help me in all stage of life.

Tampere, September 2019

Amir Baldari

# CONTENT

1.INTRODUCTION .....	1
2.THEORETICAL BACKGROUND .....	4
2.1 NFC .....	4
2.2 NFC applications .....	5
2.3 NFC device energy harvesting .....	7
2.4 Link Budget for NFC .....	10
2.4.1. Forward Link .....	10
2.4.2. Reverse Link .....	11
2.5 Analogue to digital converter (ADC) .....	12
2.5.1. ADC definition .....	12
2.5.2. Resolution of ADC .....	13
2.6 Resistive sensor .....	14
3.IMPLEMENTATION (EXPERIMENT) .....	16
3.1 NFC sensor (NHS3152) .....	16
3.2 Temperature measurement .....	19
3.3 LPCXpresso board .....	22
3.4 Resistance measurement .....	23
3.5 NFC Data Exchange Format (NDEF) message .....	24
3.6 LPCXpresso C project programming .....	27
3.6.1. C programming procedure .....	27
3.6.2. Flashing procedure .....	31
4.RESULT AND ANALYSIS .....	34
4.1 Resistance measurement applied methods .....	34
4.1.1. Resistance measurements based on NHS3152 passive loop .....	34
4.1.2. Resistance measurements by voltage division .....	36
4.1.3. Resistance measurements by reference voltage (Wheatstone bridge) .....	39
4.2 Wheatstone bridge sensitivity .....	43
4.3 Analysing of screen-printed stretchable carbon interconnects .....	44
CONCLUSIONS .....	45
REFERENCES .....	46
APPENDIX A: WRITTEN C CODES IN LPCXPRESSO	

## LIST OF FIGURES

<b>Figure 1.</b>	<i>Block diagram of designed system.....</i>	<i>2</i>
<b>Figure 2.</b>	<i>NFC applications .....</i>	<i>7</i>
<b>Figure 3.</b>	<i>Induction between Tag and Reader in NFC/RFID .....</i>	<i>8</i>
<b>Figure 4.</b>	<i>Rectangular NFC antenna layouts .....</i>	<i>9</i>
<b>Figure 5.</b>	<i>Time-domain NFC modulated waveform (top) and idealized response of a second order system with quality factor Q (bottom).....</i>	<i>11</i>
<b>Figure 6.</b>	<i>NHS3152 ADC/DAC block diagram.....</i>	<i>13</i>
<b>Figure 7.</b>	<i>NHS3152 block diagram .....</i>	<i>16</i>
<b>Figure 8.</b>	<i>NHS3152 pad configuration .....</i>	<i>17</i>
<b>Figure 9.</b>	<i>NXP NHS3152 Therapy Adherences.....</i>	<i>19</i>
<b>Figure 10.</b>	<i>Measured ambient temperature in 24°C by NHS3152.....</i>	<i>20</i>
<b>Figure 11.</b>	<i>LPC-Link 2 Design overview .....</i>	<i>23</i>
<b>Figure 12.</b>	<i>Designed circuit of DUT to NHS3152 by I2D and ADC/DAC.....</i>	<i>24</i>
<b>Figure 13.</b>	<i>NXP TagInfo NDEF data recorded for resistance from NHS3152 chip .....</i>	<i>27</i>
<b>Figure 14.</b>	<i>C program execution diagrams .....</i>	<i>28</i>
<b>Figure 15.</b>	<i>LPCXpresso IDE software.....</i>	<i>29</i>
<b>Figure 16.</b>	<i>Flashing the NHS3152 by Flash Magic software .....</i>	<i>32</i>
<b>Figure 17.</b>	<i>Flashing procedure of NHS3152 by LPC Link2 board .....</i>	<i>33</i>
<b>Figure 18.</b>	<i>Resistance measurement based on NHS3152 passive loop.....</i>	<i>34</i>
<b>Figure 19.</b>	<i>Resistance measurements by voltage division .....</i>	<i>36</i>
<b>Figure 20.</b>	<i>Resistance measurements by reference voltage (Wheatstone bridge) .....</i>	<i>39</i>
<b>Figure 21.</b>	<i>Measured resistance values for 10 kΩ .....</i>	<i>40</i>
<b>Figure 22.</b>	<i>Measured resistance values for 50 kΩ potentiometer.....</i>	<i>41</i>
<b>Figure 23.</b>	<i>Measured resistance values for 50 kΩ potentiometer in linear region .....</i>	<i>41</i>
<b>Figure 24.</b>	<i>Wheatstone bridge sensitivity curve in linear region of designed circuit.....</i>	<i>43</i>
<b>Figure 25.</b>	<i>Screen-printed stretchable carbon interconnects.....</i>	<i>44</i>

## LIST OF TABLES

<b>Table 1.</b>	<i>NFC and RFID comparison .....</i>	<i>4</i>
<b>Table 2.</b>	<i>NFC tag types.....</i>	<i>5</i>
<b>Table 3.</b>	<i>NHS3152 pin description.....</i>	<i>18</i>
<b>Table 4.</b>	<i>Resistance measurement based on NHS3152 passive loop.....</i>	<i>36</i>
<b>Table 5.</b>	<i>Resistance measurements by voltage division .....</i>	<i>37</i>
<b>Table 6.</b>	<i>Resistance measurements by reference voltage (Wheatstone bridge) .....</i>	<i>40</i>

## LIST OF CHARTS AND PROGRAMS

<b>Chart 1.</b>	<i>NDEF structure.....</i>	<i>25</i>
<b>Chart 2.</b>	<i>Flowchart of implemented C program in LPCXpresso.....</i>	<i>30</i>
<b>Program 1.</b>	<i>C codes for temperature measurement.....</i>	<i>21</i>
<b>Program 2.</b>	<i>C codes for main section of project.....</i>	<i>31</i>
<b>Program 3.</b>	<i>C codes for resistance measurements by NHS3152 passive loop.....</i>	<i>35</i>
<b>Program 4.</b>	<i>C codes pin definition for resistance measurements by voltage division.....</i>	<i>38</i>
<b>Program 5.</b>	<i>C codes pin definition for resistance measurement by reference voltage.....</i>	<i>42</i>

## LIST OF ABBREVIATION

ADC	Analogue to Digital Converter
ASK	Amplitude Shift Key
BW	Band Width
CMOS	Complementary Metal Oxide Semiconductor
CNT	Carbon Nano Tube
CPU	Central Process Unit
DAC	Digital to Analogue Converter
DC	Direct Current
DUT	Device under Test
DB	Decibel
ECG	Electrocardiogram
EEPROM	Electrically Erasable Programmable Read-Only Memory
EH	Energy Harvesting
FSR	Full Scale Range
GPIO	General Purpose Input Output
GUI	Graphic User Interface
IC	Integrated Circuits
IE	Inverse Effect
IEC	International Electrotechnical Commission
iOS	iPhone Operating System
IoT	Internet of Things
ISM	Industrial, Scientific and Medical
ISO	International Organization for Standardization
LSB	Least Significant Bit
NDEF	NFC Data Exchange Format

NFC	Near Field Communication
NRZ	Non-Return-to-Zero
NVM	Non-Volatile Memory
NVIC	Nested Vectored Interrupt Controller
PMU	Power Management Unit
POR	Power-On Reset
RFID	Radio Frequency Identification
RF	Radio Frequency
RAM	Random Access Memory
SNR	Signal to Noise Ratio
SRAM	Static random-access memory
SWD	Serial Wire Debug
WDT	Watchdog Timer
URI	Uniform Resource Identifier



# 1. INTRODUCTION

In communication field, Near-Field Communication (NFC) is known as a short and adjoining range wireless communication protocol within the branch of Radio Frequency Identification Systems (RFID) which enables bidirectional and exchangeable communication between two devices in short distance from each other. NFC becomes massively integrated with smartphones mainly to utilize them as data logger, payment and banking assistant systems to be replaced by classical credit cards [1][2].

To avoid cut-off and third parties to interrupt the data transaction, the short distance should be communicated the devices contributes an extra level of security. However, this proximity between the NFC tag and readers also brings other useful and practical properties to NFC. Presumably, one of the most useful and interesting features is the probability to energize and power up the designed receiver from the magnetic field which generated and powered by the NFC reader, and in the electronic market is known to energy harvesting (EH) [3][4].

Nowadays, by combination communication and electronic technology together, it is feasible to access and discover several fabricated integrated circuits (IC) from the paramount NFC manufacturers with energy harvesting capabilities in the market [5][6]. These chips use and applicate Power Management Unit (PMU) for adaptable control of power consumption and regulator to provide a constantly stable voltage at the output of the received over range magnetic field more than an acknowledged threshold. So, it brings the design of passive designed tags with electrical components that consume a few current less than milliamperes. Furthermore, supporting an external analogue input is another important feature of some chips which could be implemented to add additional sensors to be worked in NFC field by taking advantage of digital to analogue converter (DAC), analogue to digital converter (ADC) and the Current-to-Digital (I2D) converter based on a 16-bit current to voltage frequency (I/F) converter with optimized integration time. The assigned input analogue signal is selected and configured from any input bus via multiplexer and subsequently transfers through an input scaler circuit as per Figure1 [7][8][9].

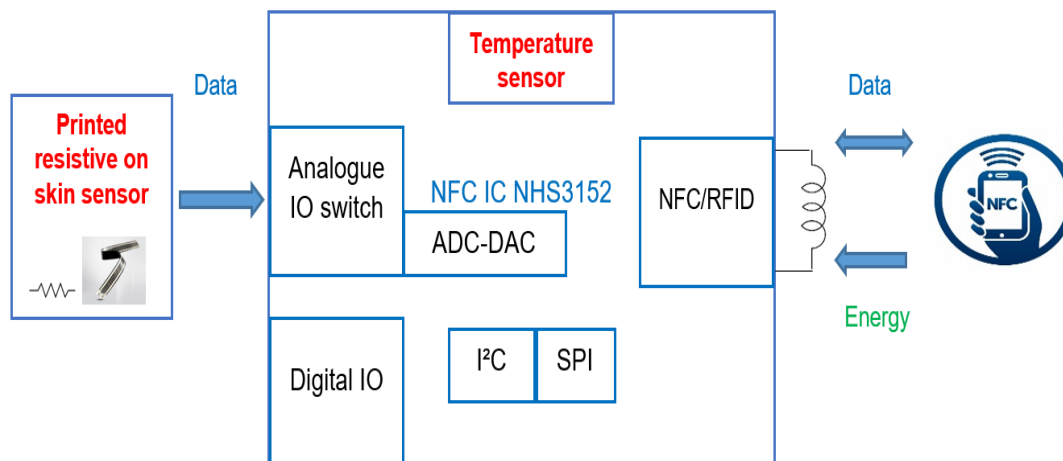

**Figure 1 Block diagram of designed system**

The NXP NHS3152 is an integrated circuit (IC) selected especially for therapy adherence logging and monitoring. As shown in Figure 1, it is an embedded NFC based interface, a resistive network, an internal sensitive temperature sensor, sensing analogue and digital interface, and a direct 3V battery connection.

All collection of existing characteristics supports an operative flexible system solution with a single layer foil implementation for pill usage monitoring and minimal number of external components. The NHS3152 functions either active (battery-powered) or passive (NFC - powered).

The high speed and embedded ARM Cortex-M0+ provides flexibility and wide range of capability to the users and engineers of this IC to reach their own practical and dedicated solution. The main features of NHS3152 are multiple power modes (active, sleep, deep sleep and deep power down) and a selectable/switchable central process unit (CPU) frequency of up to 8 MHz, for power consumption of ultra-low chip [10][11].

Clearly, it is depicted that energy is conducted from NFC reader device to receiver in one direction and data can be transferred subsequently between both reader and tag. In addition, the data transfer is shown from resistive sensor to tag which it will be recorded continuously as the magnetic field energizes the system from NFC reader.

Resistive monitoring printed sensor is vital for healthcare (therapy adherence monitoring and logging), security and other industrial in order to control the force, temperature and movement of different parts of human body or other machineries. For example, in strain sensor, whenever a piece of electrically conductive metal is forced under flatten compressive low pressure (without deformation), it will be trimmed and broadened. If these stresses are maintained within the flexible elastic limit of the metal strip (in the way that this metal strip does not permanently buckle), it can be utilized as a measuring practical element for physical force, by measuring its resistance the amount of applied force. Another usage is thermistor which works on the principle that resistance of some special materials changes

with the exchanging in their temperature. Whenever the temperature of the under-test material changes, subsequently the resistance will be changed and can be measured simply, calibrated and adjusted against the input variation. Furthermore, it is quite useful for other practical purposes related to civil and construction engineering [11].

The main aim of this research proposes an NFC base tag (NHS3152) consisting of an external printed flexible and stretchable resistive sensor that are used in wearable mobile applications to detect and monitor physical sensing platform of human body by taking advantage of energy harvesting of electromagnetic wave.

Corresponding to it, growing in the criteria and requirements for the effective and development implementation of such sensors is explained here. In addition, it is tried to design a user-friendly application for smartphones by measuring an internal temperature sensor of NHS3152.

General purpose of this system is proceeding the comfortable protocol to access and log the last updated data which has been transferred by NFC based sensors and ability to harvest the energy frequently, without using any computer connections and software that occupies extra space and expert user to work with them. In addition, it has great capabilities of linking this project to existing smart home, industrial and healthcare internet of things (IoT) accomplished technologies which are developed nowadays.

This thesis explanation will be started in chapter 2 with the description of the Near Field Communication (NFC) and its energy harvesting feature which was developed consequently and the overall knowledge about NFC technology. Afterthought, the analogue to digital converters (ADC) principle in electronic circuits with description about resolution of it, will be explained briefly. During the thesis practical parts in chapter 3, the NFC implemented sensors (NXP NHS3152) in this project will be described in details and the technical aspects of the technologies such as NFC Data Exchange Format (NDEF) message, NXP TagInfo application, LPCXpresso link and IDE software, C programming, flashing procedure by Flash Magic and etc. will be covered completely. In the main part of this thesis (chapter 4), the resistance measurement of connected analogue input to NXP NHS3152 NFC IC will be analysed and discussed altogether step by step with explaining about programming and designing the circuits by examining screen-printed stretchable carbon interconnects value. Finally, the thesis will be summarized as a conclusion of this work with the capability to develop and progress in future.

## 2. THEORETICAL BACKGROUND

Developing the NFC technology in different industrial areas is the main purpose to explain the most important NFC characteristic in this section by focusing on the variety of applications and energy harvesting features.

### 2.1 NFC

In telecommunication and electronic, Near-field communication (NFC) is defined as a high frequency (HF) radio-frequency identification system (RFID) that enables the fast and reliable communication up to 424 Kbit/s between devices over a short range less than 22 cm using the 13.56 MHz RFID band which operate based on ISO-14443 and Felica standards [12].

The comparison between RFID and NFC protocols are described shortly in Table1 to demonstrate similarities and differences of this two briefly.

**Table 1.** NFC and RFID comparison

Parameters	RFID	NFC
Network type	Point to Point	Point to Point
Communication	Unidirectional	Bidirectional
Power consumption	Varies with frequency	<15 mA
Range	Up to 100m	<0.22m
Frequency	LF/HF/UHF/Microwave	13.56 MHz
Bit rate	Varies with frequency	>424 kbit/s
Security	Hardware and protocol level	Hardware and protocol level
Setup time	<0.1 s	<0.1 s
Continuous sampling	No	Yes

In general point of views, NFC device can be operated as:

- NFC card emulation by empowering NFC -enabled devices such as NFC readers and smartphones to act like reliable and intelligent cards, allowing all kind of users to do transactions.

- NFC reader or writer by enabling NFC -based devices to access the data which has been stored on tags.
- NFC peer-to-peer by empowering two NFC -based devices such as smartphone to connect and communicate together for exchanging data [12].

The NFC tags can be classified into active, semi-passive and passive based on the availability of a power supply. An active tag is energized from external power supply such as a battery, however passive tag is based on energy harvesting from NFC enabled device such as smartphone without utilizing any external power supply. Generally, there are four types of tags that defined by the NFC forum, all based on the RFID control protocols. Also, there is a fifth which is compatible, however, not strictly part of the NFC specification. Types 1, 2, and 4 are operating based on ISO-14443A, and type 3 is operating based on ISO-18092 [13][14]. Tag details are categorized as per Table2.

**Table 2.** NFC tag types

Tag type	Standard	Communication Speed	Protocol	Memory	Example
Type 1	ISO 14443A	106 Kbit/s	NFC A	96-2K Byte	Innovation Topaz
Type 2	ISO 14443A	106 Kbit/s	NFC A	96-2K Byte	NXP Mifare Ultralight
Type 3	ISO-18092 and JIS-X-6319-4	212 or 424Kbps	NFC F	>1Mbyte	Sony FeliCa
Type 4	ISO 14443A-B	106, 212, or 424Kbps.	NFC A-B	2, 4, or 8KByte	NXP DESFire
Type 5	ISO 14443A-B	106Kbps	NFC A-B	192, 768, or 3,584 Byte	NXP Mifare Classic 1K

Other characteristics that differentiate between one tag and others could be related to hardware complexity, security and encryption.

## 2.2 NFC applications

As already discussed, the applications developed by the new short-range NFC technology is quickly expanded to catch some of the important application, it could be interesting to mention to some of them that it shows a better sight of comprehending to this technology in real life (Figure 2).

- Payment

In every situation, banking service is one of the most critical subjects that many NFC applications in payment, provides different users to do the fast purchasing in a shortest time and secure way. This application enables anyone to go shopping with electronic money and furthermore buy, save and use electronic tickets such as theatre, cinema, public transportation tickets and many other purposes.

- Identification

Instead of using Identification (ID) Cards or piece of official paper for example passports, NFC gives the possibility of utilizing mobile phones for person's identification. For example, in many countries, it is possible to store students Identification Cards on the smart phones. By this way the students can book the searching room, register to the courses, open the locked campus doors, buy food from the university canteen, borrow books from the library and totally where ever the student ID is required, they are able to use their mobile smart phones.

- Sharing Information

For downloading data from digital gadget and devices which have a capability to save the data like smart phones and cameras is made possible to utilize NFC technology. The data that is saved and exist on any tagged object can be accessed using easily an NFC equipped smartphone in order to download different information.

- Electronic keys

The key technology makes it possible to utilize NFC instead of mechanical classic keys for the offices, houses or cars.

Many other existing applications are developed such as, lock on personal computers, parking meters, vending machines, etc. utilized NFC to be accessible straightforwardly.

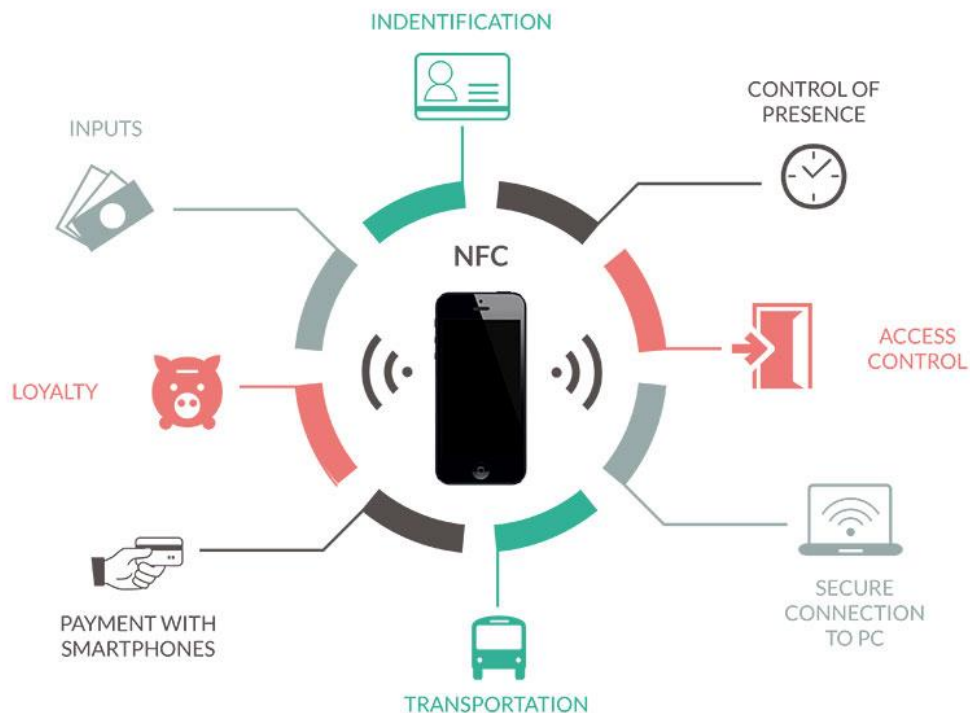

**Figure 2 NFC applications [28]**

### 2.3 NFC device energy harvesting

Typically, in passive or battery less mode, the tag is fully powered from radio frequency (RF) field. In this designed mode, the NFC -enabled sensor saves and utilizes energy from inductive RF emissions from a reader such as android smartphone to energize the NFC sensor interface and RF transmissions.

In semi-passive or battery-assisted mode, the NFC-enabled sensor can be operated stand-alone in applications which required independent and continuous monitoring as data loggers. The actual lifetime of a sensor tag depends on operation in both modes: in semi-passive mode until the battery will be empty, and subsequently, in passive mode. Functionally, data is completely stored in non-volatile memory (NVM) and retained when the device power is disconnected [15][16].

Generally, in existing NFC sensor tags the Power Management Unit (PMU) is responsible to control and regulate the switching between available external battery or NFC field power sources which can be optimized in a completely active mode, whenever the chip is accessible and enabled, power and clocks to selected in peripheral connection for power consumption or in sleep mode which clock of processor is disabled.

NFC lays on stable electromagnetic induction filed between two coupling loop tag and reader sides' antennas (Figure 3). It conducts within the globally common and free access unlicensed radio frequency (RF) industrial, scientific and medical (ISM) band of 13.56 MHz on the ISO/IEC 18000-3 air interface in communication rate ranging from 106 to 424 Kbit/s.

The receiver antenna is connected to the internal tag rectifier, by ability to take energy from the RF field that is used to power up the tag electronics.

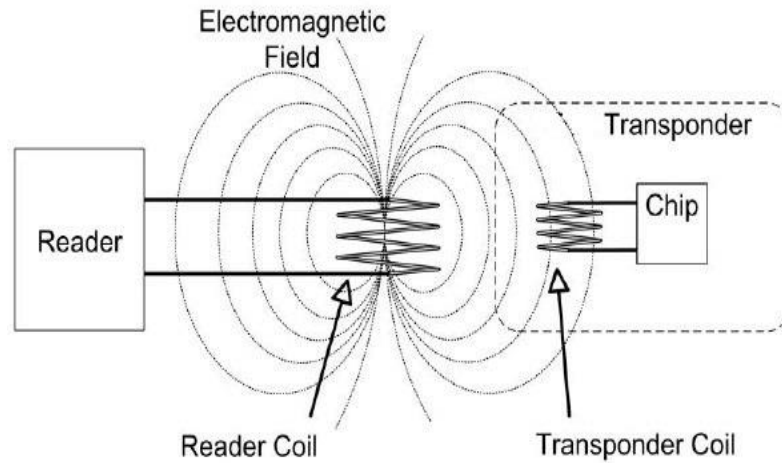

**Figure 3 Induction between Tag and Reader in NFC /RFID**

Besides, the internal designed logic demodulates the amplitude shift key (ASK) message from the reader. So, practically the tag transponder, which is assumed to be completely passive, responds, utilizing the passive evaluated load modulation technique, by implementing the change of antenna impedance for designed NFC tag.

In addition, the passive evaluated load modulation spectrum including the radio frequency (RF) carrier, fluctuating in two sidebands between 12.712 MHz and 14.408 MHz, and modulated sidebands on these two specific subcarrier signals. All the transmitted data are carried in the two sidebands. The 13.56-MHz RF carrier, therefore, does not have to be transmitted by the transponder [14][17].

According to the Magnetic flux density around the NFC reader coil is defined as in equation (1):

$$B = \frac{\mu_0 N I a^2}{2r^3} \text{ Weber/meter,} \quad (1)$$

Where:

$I$  is the current through the NFC reader coil

$N$  is the number of windings in the NFC reader coil

$a$  is its radius

$\mu_0$  is the permeability of free space ( $4\pi \times 10^{-7} \text{ H/m}$ )

$r$  is the perpendicular distance from the NFC reader coil centre to the point of observation.

The NFC tag coil will try to capture as much as possible of this magnetic flux and transfer it in to current/voltage according to Faraday laws in equation (2)(3)(4)[14][16]:

$$V = N \times d\phi, \quad (2)$$

$$\phi = \int B \cdot dS, \quad (3)$$

$$V = 2 \pi f N_{TAG} QBS \cos \alpha, \quad (4)$$

Where:

$S$ , is the area of the tag coil

$N_{TAG}$  is the number of windings in the NFC tag coil

$f$ , is the frequency of the wave

$\alpha$ , is the alignment angle between the centres of the two coils

$Q$ , is the quality factor of the resonant circuit and can be defined as equation (5):

$$Q = 1 / \left( \frac{R_{COIL}}{2\pi f L_{TAG}} + \frac{2\pi f L_{ANT}}{R_{TAG}} \right), \quad (5)$$

Where:

$R_{TAG}$  is the equivalent resistance of the whole tag

$R_{COIL}$  is the resistance of the NFC tag coil

$L_{TAG}$  is the inductance of the NFC tag coil and it depends on the shape of the coil, radius of the coil, number of the windings, thickness of the windings, length of the coil.

For a square shape coil, as the one shown in Figure 4, L antenna is given by equation (6):

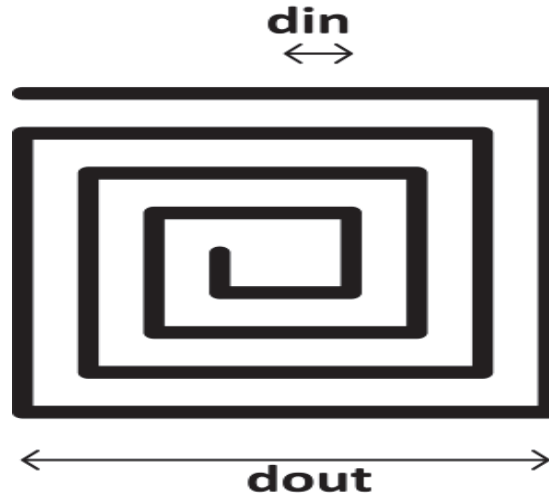

**Figure 4 Rectangular NFC antenna layouts [14]**

$$L_{ANT} = K_1 \mu_0 N \frac{d}{1+K_2 P}, \quad (6)$$

Where:

$d$  is the mean coil diameter  $\frac{(dout+din)}{2}$

$$P = \frac{(dout - din)}{(dout + din)}$$

$N$  is the number of windings

$K_1$  and  $K_2$  depends on the shape and in this specific case, they are 2.34 and 2.75 consecutively [14].

## 2.4 Link Budget for NFC

### 2.4.1. Forward Link

In practice establishing stable communication between the NFC reader such as smartphone and the tag (forward link) and ensuring that enough electromagnetic power for the radio frequency (RF) to direct current (DC) conversion to energize the electronic circuitry, is the aim to reach the maximum power transfer from the reader to the tag. For this purpose, the delivered power to the tag IC ( $P_d$ ) should be above a threshold power ( $P_{TH}$ )[19]:

$$P_d = P_S G_T (f_c) > P_{TH}, \quad (7)$$

Where:

$P_S$  is the power transmitted at the reader side,

$G_T$  is the available gain at the centre frequency,  $f_c$ .

To this end, efficiency should be maximized. The maximum available efficiency is obtained from the optimized gain in corresponding conditions,  $G_{T\_max}$ . This efficiency is capable of measuring especially from the S-parameter (Scattering parameter which explained the electrical performance in linear electrical designed networks in experiencing various steady state stimuli condition by electrical signals) measurements and expressed as a function of each parameter by equation (8)[19]:

$$\chi = k^2 Q_1 Q_2, \quad (8)$$

Where:

$k$  is the magnetic coupling between the reader and tag coils ( $k = M/\sqrt{L_1 L_2}$ )

$Q_1$  and  $Q_2$  are the quality factors of the reader and tag coils, respectively.

$$\frac{P_{d-max}}{P_S} = \eta_{max} = G_{T\_max} = \frac{\chi}{(1+\sqrt{1+\chi})^2}, \quad (9)$$

In addition, power transfer could be maximized by levelling up the quality factor of the antennas or improving the coil coupling that is a function of the distance between the both side's antennas. However, a high Q factor would effect on bandwidth and long-time constants, creating the worst distortion in the transferred, modulated signal.

For confirming that the communication do its function appropriately, the maximum value of the Q factor of the initiator antenna have to be such that the bandwidth BW (-3 dB), which is equal to  $f_c/Q$ , is at least able to channel all the frequencies that contained in the spectrum of the signal modulating the carrier frequency. The bandwidth of the forward link is the same as the modulation sidebands of the carrier and is dependent on the modulation scheme as per the reader side. In the worst case condition (in compare with the maximum value,  $Q_{1\_max}$ , of the initiator antenna circuit), the fundamental bit rate of the square wave signals (50% cyclic ratio in non-return-to-zero (NRZ) bit coding) of that digital data stream must be not less than half of the bandwidth BW of the tuned circuit. The result is that  $Q_{1\_max}$  is limited to  $f_c/(2 \times \text{bit rate})$ .

Unfortunately, for NFC uplink ISO 18092 and ISO 14443, type A, in order to ensure maximum energy transference, the carrier is modulated using ASK (100% the modulation index) and modified Miller coding. As per modified Miller bit coding, a pause on the carrier frequency of duration,  $T_p$ , is made. This pause,  $T_p$ , is equivalent to the transmission of a frequency in time period of  $2T_p$ , which is an equivalent bit rate of  $(1/2T_p)$ . Another interpretation is defined in time domain. Figure 5 indicates, the amplitude envelope that decreases exponentially with time constant,  $\tau = Q/(\pi f_c)$ . If the envelope will be vanished in short time constants, the reader Q factor will be limited by equation (10) [18][19].

$$Q_{1_{max}} = T_p f_c, \quad (10)$$

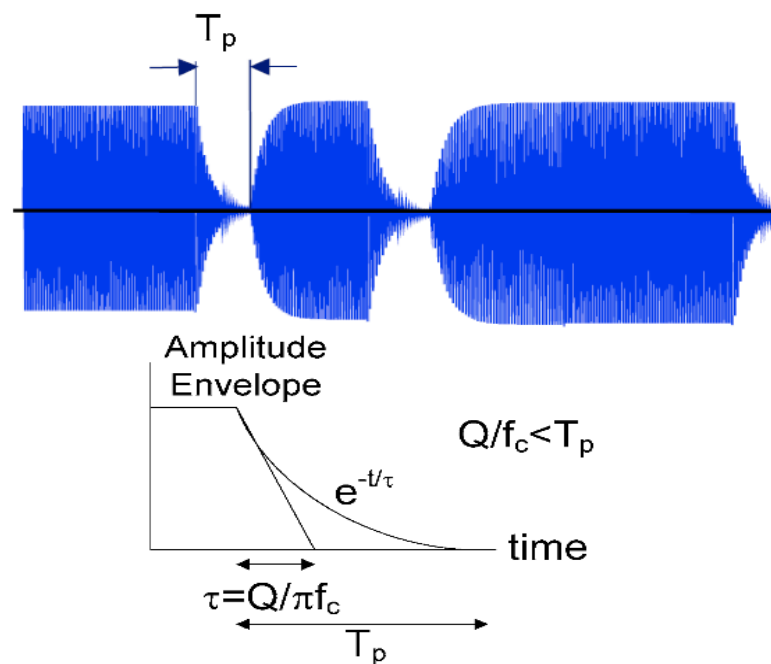

**Figure 5 Time-domain NFC modulated waveform (top) and idealized response of a second order system with quality factor Q (bottom) [19]**

Generally, based on NFC forum standard ISO 14443, the maximum defined quality factor is 40 (highest design tolerances around 35) at 106 kbit/s. Practically for applications which utilize NFC IP2–ISO 21481 with the license to use NFC–V and ISO 15693 targets, in any bit rate, by the shortest time present in the communication protocol for the uplink is defined as a “pause” lasting  $T_p = 9.44 \mu\text{s}$ . In this case,  $Q_{1_{max}} = 128$ , which generally can be reduced to  $Q_{1_{max}} \text{ usable} = 100$ , by considering the design tolerances. Normally,  $Q_{1_{max}}$  values are feedforwarded to obtain and applicable to reduce utilizing serial resistors [19].

## 2.4.2. Reverse Link

As, the Q factor will be increased, bandwidth decreased, and attenuation levelled up at the subcarrier frequencies. Subsequently, the return signal will be weaker because of higher

attenuation. So, the return signal power ( $P_b$ ) is lower than the reader sensitivity ( $S_{\min,reader}$ ) and the reader cannot decode the load modulation.

This condition in the reverse link can be mathematically expressed as equation (11):

$$P_{bs} = P_m G_T (f_{sub}) > S_{\min,reader} \quad (11)$$

Where:

$G_T (f_{sub})$  is defined as a system transducer gain at the subcarrier frequency

$P_m$  is the modulating power as per this formula ( $P_m = m^2 / 4 P_d$ ) which depends on the modulating factor (m).

Typically, sensitivity of reader is 110 dB lower than average level of transmitted carrier signal ( $S_{\min,reader} = -110$  dBc).

The read range is able to be limited by the forward link and the reverse link.

Furthermore, in both cases, transducer gain is based on the coupling coefficient between the reader and tag antennas, k [18][19].

## 2.5 Analogue to digital converter (ADC)

### 2.5.1 ADC definition

One of the most significant features of semiconductor capability in the sensing subsystem is the ADC which converts an analogue sensor actual reading values into a digital value. The most important item that should be considered here is the power consumption of an ADC that depends on the data conversion speed and the resolution of the ADC.

In electronic field, many circuits have been designed to convert an analogue signal with same power and correct data. The selection of the ADC for a specific application is usually defined by the requirements; if speed is main criteria, a fast ADC to be implemented; if precision is main criteria, an accurate ADC to be used and if space is main criteria, a compact ADC to be designed.

All analogue to digital converters function under the same principle. Converting a signal to a certain number of bits N is an important key of working principle for ADCs. Generally, the sequence of bits demonstrates the number and each bit has the double of the weight of the following one by starting from the Most Significant Bit (MSB) up to the Least Significant Bit (LSB). At the end, it was tried to find the sequence of bits  $b_{n-1}, b_{n-2}, \dots, b_0$  that represents the analogue value  $V_{in}$  as equation (12).

$$V_{in} = \sum_{k=0}^{n-1} b_{in} 2^k \frac{V_{ref}}{2^n}, \quad (12)$$

The MSB contains weight  $V_{ref}/2$ , subsequently  $V_{ref}/4$  and so on... it is clear that the LSB weight is  $V_{ref}/2N$ . After that, more converted bits guide to more precision in the digital

representation. In designing aspect there are many types of ADC circuits such as Integrating or Dual-slope, Flash Pipelined, Sigma Delta ( $\Sigma\Delta$ ), Successive Approximations Register (SAR). In NHS3152 NXP chip (used chip in this thesis), there is a fundamental limit on the speed resolution product per unit for example, 12-bit ADC operation at 80 kSample /s, power consumption of ADCs in NHS3152 NFC tag of NXP Company [11].

The ADC and DAC peripheral are according to a 12-bit approximation successive charger distribution analogue to digital converter. However, the peripheral acts as either an analogue to digital converter or a digital to analogue converter, is relating to which start bit is defined to the control Clock Register as per Figure 6. Furthermore, the input port of ADC and output port of DAC output are connected to the analogue buses and on-chip transducers via an analogue multiplexer [11].

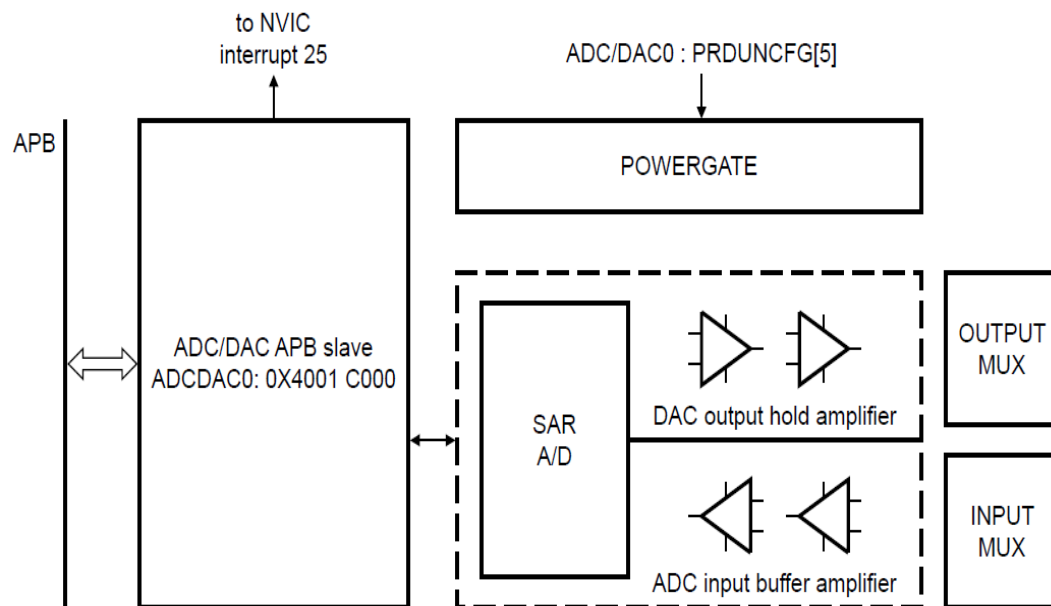

**Figure 6 NHS3152 ADC/DAC block diagram [11]**

## 2.5.2 Resolution of ADC

It is the number of bits that an analogue to digital converter (ADC) uses to represent its analogue input and it can be improved by reducing the reference input. Together with the dynamic range of the sensed parameter, it defines the smallest step we can detect, and consequently the resolution of the ADC. For example, in 140  $\mu\text{A}$  current to digital (I2D) current, resolution bit for NHS3152 NFC tag maximum Resistance is 5.0 then ADC will give  $2^5 = 32$  [11].

The resolution rate of ADC in microprocessors determines and calculates the magnitude of the major error of quantization and subsequently estimates the maximum reachable average signal to noise ratio (SNR) for an ideal ADC by neglecting oversampling. Normally, the values of SNRs are stored electronically in binary (digital) form, so the resolution is usually demonstrated as the audio bit depth.

Resolution could also be defined electrically and easily expressed in voltage. The variation of voltage required to guarantee a fluctuation in the output code level which defined as the least significant bit (LSB) voltage. The resolution  $Q$  of the ADC is equal to the LSB voltage. The voltage resolution of an ADC as per below equation is equal to its overall voltage measurement range which divided by the number of intervals [20]:

$$Q = \frac{E_{FSR}}{2^M}, \quad (13)$$

Where:

$M$  is the ADC's resolution in bits

$E_{FSR} = V_{RefHi} - V_{RefLow}$  is span or full scale voltage range and  $V_{RefHi}$  and  $V_{RefLow}$  are the upper and lower extremes, respectively, of the voltages that can be coded.

Generally, the number of voltage intervals is given by equation (14) [20]:

$$N = 2^M, \quad (14)$$

## 2.6 Resistive sensor

The printed electronic sensor on flexible and stretchable substrates enables conformable sensitive electronic systems such as electronic on skin which could be wrapped and attached to different part of the body. Necessity to monitor of a human's body data, like temperature of body, heart pumping rate and blood pressure, could help and assist medical healthcare suppliers in diagnosis of dangerous adverse diseases or conditions and quickly prediction, allowing every patient to be treated more effectively and in the best time, thereby decreasing number of patient and costs of medical in the future. To reach this goal, health monitoring wearable sensors should be alert and worn by people during daily activities (even during sleep), to collation of essential body data continuously. In this respect, comfort is one of the important considerations in designing of this device. Mechanically stretchable and flexible devices could be an ideal candidate for flexible health care printed stretchable sensors and progressed to the great extent. Many types of material structures and platforms have been presented for health care monitoring equipment, for example heartbeat sensors, temperature sensors, chemical sensors, electrocardiogram (ECG) sensors, emergency drug delivery systems; especially multifunctional sensing has been used for diverse applications in addition to healthcare field. In spite of the fact that monitoring health conditions is critical issue, simultaneous monitoring the critical physical activity could make available some considerably needed important context to the data, considering an especial vital signs, such as skin force, temperature, clearly relies on activity and that real-time human health tag information itself is not entirely sufficient for the prediction and diagnosis of disease a full analysis of the wearable devices [21][22].

By this definition about different type of sensor, let's explain briefly about resistive sensor. The resistance of any kind of material relies on important four factors: Composition, Temperature length (L) and Cross-Sectional Area (A) as per equation (15).

$$R = \rho l / A, \quad (15)$$

Where  $\rho$  is resistivity of material.

To change the resistance of all materials, at least one of the above factors should be changed accordingly. Whenever the length is modified and material is stretched, it directly effects on resistance value. However, if the cross-sectional area is modified the change in resistance has an inverse effect (IE)  $r = k/A$ . In addition, Changes in material composition, specification and temperature do not affect the resistivity of a material in such a direct way.

Generally, common definition of resistive sensor is a carbon resistor that will be changed based on many physical pressures change in its material environment. The potentiometer or variable resistor which the resistance value varies with physical movement, photo resistor, the photon of lights varies the resistance value of material, thermistor that heat effects on material and resistance will change subsequently, strain gauge, the resistance varies with stress and compression and force-dependent resistor which resistance changes with applied pressure are the most common example of resistance sensors.

### 3. IMPLEMENTATION (EXPERIMENT)

The measuring and demonstration of important vital signs for personalized human body is emerging substantial interest from ambient assisted living elucidation. NFC provides a user-friendly connection and interface that is comfortable for patients. It could be used by the latency from touching the accessible readers such as smartphones and displaying the result typically less than one second. The main and important features of NFC sensors are low-cost, wearable, green and completely isolated to avoid epidemic effect and contamination between different patients.

NFC technology facilitates the professional integration with cloud services via smartphones because the user application that is used for reading and recording data from sensor can upload and download it to be connected to internet. A frequent and constant monitoring of medical parameters helps improving the diagnosis and follow-up of several privileged diseases by shortening personal attention. In the long term, in societies with aging populations, incorporating NFC sensors reduces the cost of elderly's healthcare cost.

#### 3.1 NFC sensor (NHS3152)

The NXP NHS3152 is one the NFC integrated circuit (IC) optimized and fabricated for therapy adherence monitoring and logging. By consideration about electronic circuit and design of different NFC sensors here it is tried to show he block diagram of NHS3152 is shown in Figure 7 and go through details of its features moreover [11].

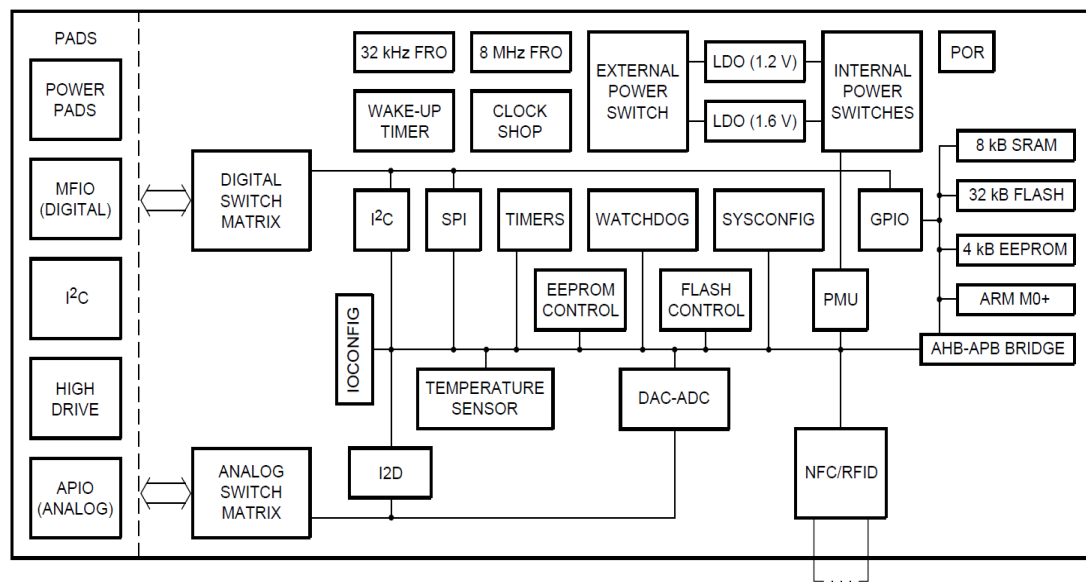
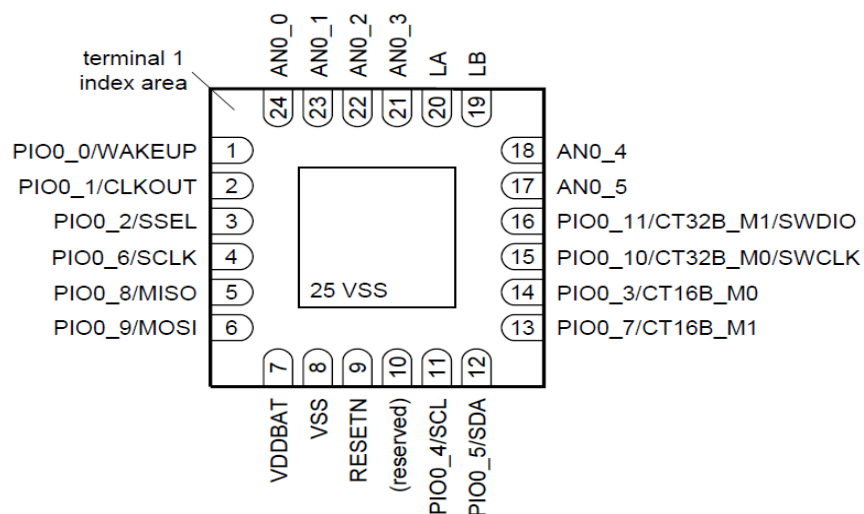

Figure 7 NHS3152 block diagram [11]

- Power management: Supporting 1.72 V to 3.6 V the external DC voltages and the NHS3152 able to be energized from the NFC field, easily activated by NFC possible, accomplishing integrated Power Management Unit (PMU) for control of power consumption, four assigned minimized power modes for ARM Cortex-

M0+: Sleep, Deep-sleep, Deep power down and Battery-off, power enabled gating for each analogue peripheral for ultra-low power operation, < 50 nA IC current consumption in Battery-off mode at 3.0 V, Power-On Reset (POR)

- Process system: the main CPU is Cortex-M0+ processor manufactured by ARM which running at frequencies of up to 8 MHz and designed based on Nested Vectored Interrupt Controller (NVIC)
- Internal memory: 32 kB on-chip flash programmable and erasable programming memory, 4 kB on-chip electrically fabricated erasable programmable read-only memory (EEPROM) of which 320 bytes are write-protected and 8 kB Static random-access memory (SRAM)
- Communication field interface: NF\_C/RFID ISO 14443 type A interface; I2C-bus interface supporting full I2C-bus specification, NFC forum type 2 compatible, I2C-bus interface and Fast-mode with a data rate of 400 kbit/s, with multiple-address recognitions and Monitor mode
- Digital peripheral: Configurable General Purpose Input Output (GPIO) around 12 pins with repeater mode and pull up and down resistors, GPIO pins with ability to be utilized as edge and level sensitive interrupt sources, High-current drivers (sink only; 20 mA) on four GPIO pins, High-current drivers (sink only; 20 mA) on two I2C-bus pins, Programmable Watchdog Timer (WDT)
- Analogue peripheral: Temperature sensor with  $\pm 0.3$  °C absolute temperature range of accuracy between 0 °C and 40 °C and  $\pm 0.5$  °C in the range -40 °C and +85 °C, support Digital-to-Analog Converter (DAC), Analog-to-Digital Converter (ADC), Current-to-Digital Converter (CDC), 6 distinguished analogue I/O pins, adjustable analogue on chip switch
- Clock generation: RC oscillator 8 MHz internal, trimmed accuracy to 2 %, that can access the system Clock, Timer oscillator operating at 32 kHz linked to the RTC timer unit [11].



**Figure 8 NHS3152 pad configuration [11]**

In Figure 8 and Table 3, the pad and pinning configured positions and descriptions of NXP NHS 3152 the HVQFN24 package (It is used in this thesis) is shown to be more familiar with general layout.

**Table 3.** NHS3152 pin description

Pin	Pin name	Description
1	PIO0_0/Wake up	GPIO Deep power-down mode wake-up
2	PIO0_1/Clock out	GPIO Clock output
3	PIO0_2/SSEL	GPIO SPI/SSP serial select line
4	PIO0_6/SCLK	GPIO SPI/SSP serial clock line
5	PIO0_8/MISO	GPIO SPI/SSP master-in slave-out line
6	PIO0_9/MOSI	GPIO SPI/SSP master-out slave-in line
7	VDDBAT	positive supply voltage
8	VSS	ground
9	RESETN	external reset input
10	Reserved	
11	PIO0_4/SCL	GPIO I2C-bus SCL clock line
12	PIO0_5/SDA	GPIO I2C-bus SDA data line
13	PIO0_7/CT16B_M1	GPIO 16-bit timer match output 1
14	PIO0_3/CT16B_M0	GPIO 16-bit timer match output 0
15	PIO0_10/CT32B_M0/SWCLK	GPIO 32-bit timer match output 0 ARM SWD clock
16	PIO0_11/CT32B_M0/SWDIO	GPIO 32-bit timer match output 1 ARM SWD I/O
17	AN0_5	to AN0_BUS5
18	AN0_4	to AN0_BUS4
19	LB	NFC antenna/coil terminal B
20	LA	NFC antenna/coil terminal A
21	AN0_3	to AN0_BUS3
22	AN0_2	to AN0_BUS2
23	AN0_1	to AN0_BUS1
24	AN0_0	to AN0_BUS0

The NHS3152 therapy Adherence chip is an IC optimized for temperature monitoring, supporting external input or output and logging. The embedded NFC interface with LPC-LINK2 interface module by using LPCXpresso allows us fully NF\_C-forum standards-compliant communication, external I/O (6 analogue pins and thirteen switches), an internal temperature sensing and direct battery connection. Thanks to computer and USB port which supports a functional system result with a minimum amount of any other external components (Figure 9).

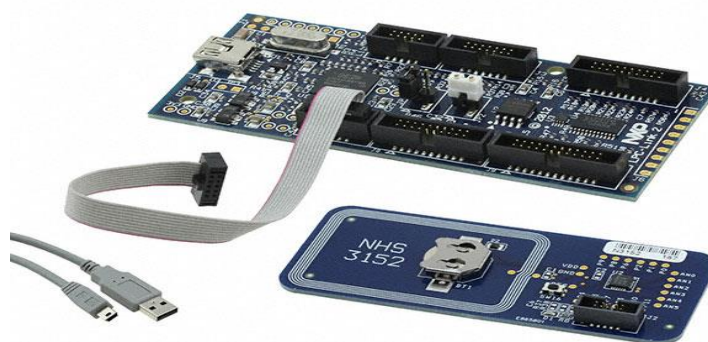

**Figure 9 NXP NHS3152 Therapy Adherences [24]**

### 3.2 Temperature measurement

The cheap and user-friendly monitoring systems are required for therapy control on body applications. A battery less, low budget cost and NFC field powered component able for measuring resistance and temperature straightforwardly. The data are depicted on smartphone android or iPhone Operating System (iOS) application or could be uploaded to the cloud for storage and sharing. The temperature of devices is measured with accurate, high precision, zoom analogue to digital converter. The analogue part can measure a highly temperature-dependent in equation (16) [11].

$$X = V_{be} / \Delta V_{be}, \quad (16)$$

In this formula,  $V_{be}$  is the bipolar transistor base-emitter voltage value. By dropping voltage over a diode formed in the base-emitter junction of a bipolar transistor the temperature value is measured by correspondent sensor. It compares the  $V_{be}$  value at different flowing current levels which chased the  $\Delta V_{be}$ .

Furthermore, this reference depicts that conventional actual low power resistive sensors could be practically integrated within the NFC tag for developing the new generation of internet of things (IoT) devices [2][11].

Here the use of the temperature sensing feature of the NXP NHS3152 internal temperature sensor node ICs is described. The temperature sensor is integrated into the NXP chip and can measure temperatures over a wide range accurately. The temperature sensor block measures the temperature of the die and outputs a calibrated value in Kelvin. It measures  $\pm 0.3$  °C absolute temperature accuracy between 0 °C and 40 °C, and  $\pm 0.5$  °C between -40 °C to +85 °C.

The temperature sensor calibration values are determined during manufacturing. The user can provide custom parameters A, B, and alpha to increase the accuracy. For calibration, the raw value X is needed, and high accuracy measurement is recommended. Internally, the following equation (17) is used to obtain the calibrated temperature output [11]:

$$T = A \frac{\alpha}{(\alpha + X)} + B , \quad (17)$$

Which the calibration values A, B, and alpha for the default resolution settings are determined during the calibration phase of the manufacturing process and stored in EEPROM with Register base address of the temperature sensor block (0x4006 0000) and high-precision zoom-ADC.

For testing NHS3152, the internal temperature sensor is programmed (main part is shown in program 1) and the actual ambient temperature has been recorded in fully passive loop by NFC TagInfo. In conclusion, the result was satisfying by comparing to external existing temperature sensors as per Figure 10 in 24°C ambient temperature in compare with google current weather website.

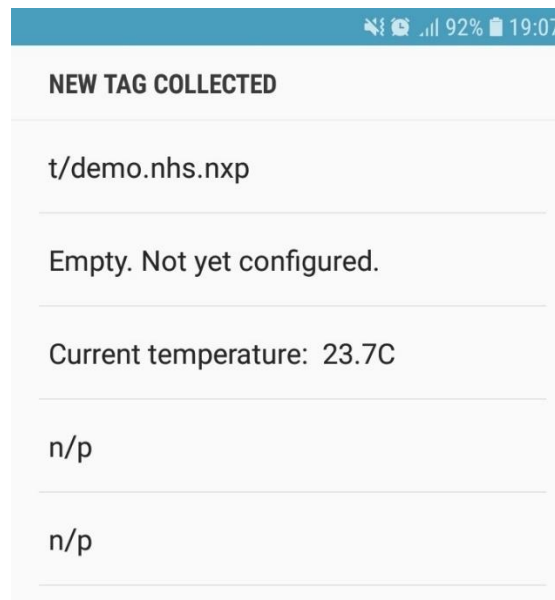

**Figure 10 Measured ambient temperature in 24°C by NHS3152**

```

static volatile bool sMeasurementInProgress = false;
#if defined(TMEAS_CB)
static volatile TMEAS_FORMAT_T sFormat;
static volatile uint32_t sContext;
#endif

#if defined(TMEAS_CB)
void TSEN_IRQHandler(void)
{
    /* If interrupt is reached, we can safely deduct that the RDY bit was set and
    therefore the
    * TSEN_STATUS_MEASUREMENT_SUCCESS status bit is set. The
    remaining (RANGE) status bits, even when set, should not
    * invalidate the temperature measurement,
    * Hence we can always assume that, at this moment, the value present in
    the TSEN Value register is always valid.
    */
    /* Measurement ready. Read the data (thereby also clearing the interrupt). */
    int value = Chip_TSen_GetValue(NSS_TSEN);
    int output = Convert(sFormat, value);
    NVIC_DisableIRQ(TSEN_IRQn);
    Chip_TSen_DeInit(NSS_TSEN);
    {
        extern void TMEAS_CB(TSEN_RESOLUTION_T resolution,
        TMEAS_FORMAT_T format, int value, uint32_t context);
        TMEAS_CB(Chip_TSen_GetResolution(NSS_TSEN), sFormat, output,
        sContext);
    }
    sMeasurementInProgress = false;
}

```

**Program 1.** C codes for temperature measurement [24]

### 3.3 LPCXpresso board

The debugging platform LPCXpresso which have been employed in this project to programming and connecting to the NXP3152 chip pioneered by NXP company and Embedded Artists. In general, the LPCXpresso development platform includes low-cost LPCXpresso target boards to get it up and running this hardware quickly. Designed for rapid prototyping, simple, and evaluation, LPCXpresso development boards work with the MCUXpresso (Developer Software and Tools for Arm® Cortex®-M cores) or industry-leading partner toolchains with an LPC target MCUA connector for an external debug probe, Arduino Uno (the microcontroller board which it is an open board and based on the Microchip ATmega328P) and Pmod (communicating module with system boards using 6, 8, or 12-pin connectors that can carry multiple digital control signals, including SPI and other serial protocols) shield connections. This feature facilitate for access to more off-the-shelf platform expansion hardware such as MAX, V2 and V3, mbed (operating system and platform for internet-connected devices based on 32-bit ARM Cortex-M microcontrollers) support MAX, V2 boards and easy upgrade with hardware expansion baseboards, Arduino shields and Pmod boards [24].

The main purpose portion of LPCXpresso boards is ability to be connected to expansion boards such as LPC Link-2 to provide a variety of interfaces and input or output modules. The onboard debug probe can be utilized to debug other targets.

The onboard debugger LPC-Link and Link2, JTAG/SWD debug probe portion of an LPCXpresso board is referred to as LPC-Link or Link2 on later boards. In early LPC-Link boards, the traces between the LPC-link and the target can be cut to use the LPC-Link as a standalone JTAG debugger. In Figure 11 the design overview of LPC Link2 board compacted by LPC 4370 IOs which it was utilized in this project, is depicted [24].

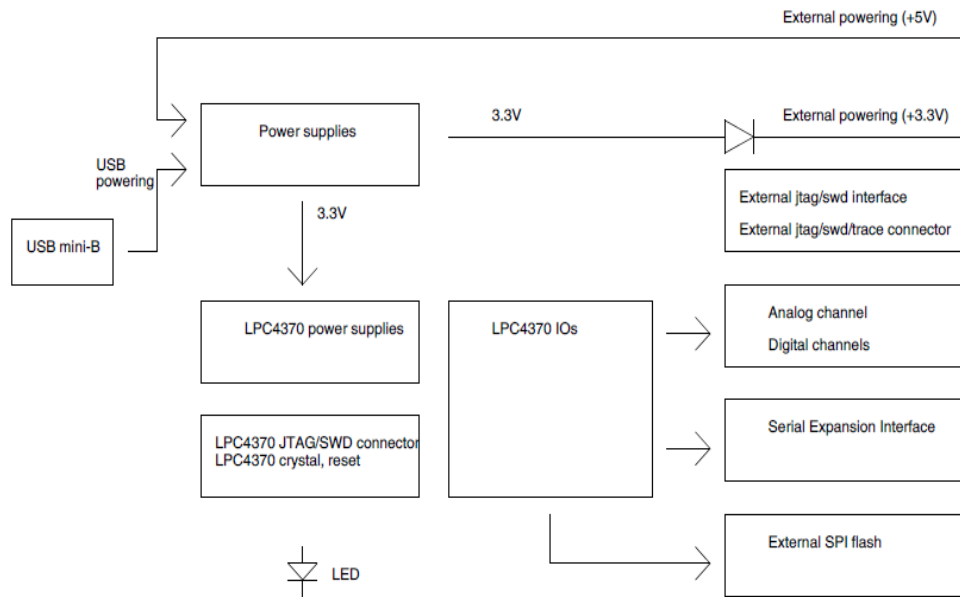

**Figure 11 LPC-Link 2 Design overview [24]**

On later LPCXpresso boards this can be accomplished with a simple jumper setting, enabling the LPCXpresso board to be easily connected to an external target such as NFC NHS chips and used to develop for a wide variety of NXP's Cortex-M0, Cortex-M3, and Cortex-M4 based applications. LPC-Link can also support Arm7™/ Arm9™ based applications. LPCXpresso MAX boards have an onboard debug probe that implements the CMSIS-DAP protocol to enable their use with MCUXpresso, mbed and a range of third-party tools. Link2 debug probes can be programmed to support CMSIS-DAP or evaluation versions of SEGGER J-Link using the LPCscrypt DFU utility [24].

The firmware residing on the FLASH memory in an NHS3152 chip, whether it is the Onetime NFC program downloader, one of the demo firmware images from the SDK, or any other firmware image can be replaced using a wired connection. With the proper setup, a program running on your PC can take control of the flash controller via the debug interface of the chip, erase the FLASH memory, and reprogram it with your new firmware. There are different options, but the focus in this thesis is on the Graphical User Interface (GUI) of Flash Magic.

### 3.4 Resistance measurement

For measuring the resistance by NHS3152, the two pins of device under test (DUT) can be configured and connected to any of the defined external analogue input pins of chip. The ADC/DAC and current to digital (I2D) are routed two analogue input by configuring the assigned input multiplexer registers of the ADC/DAC and I2D. The ADC/DAC and I2D pattern circuit is shown in Figure 12.

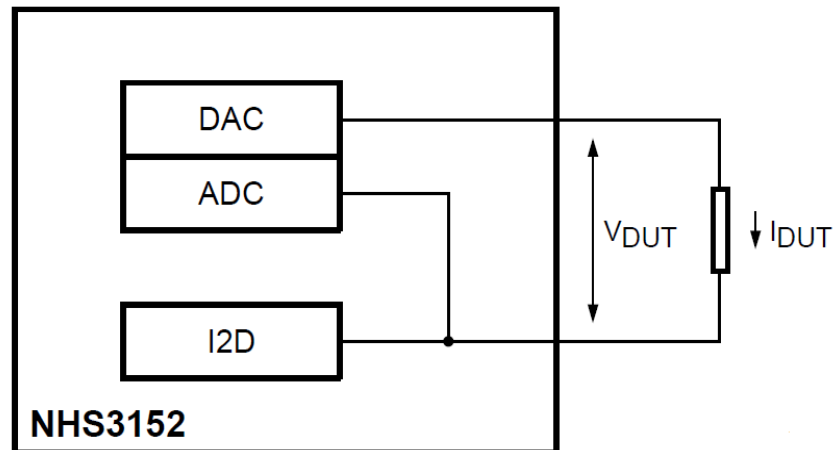

**Figure 12** Designed circuit of DUT to NHS3152 by I2D and ADC/DAC

By applying the adjusted high bias voltage to the first terminal, and sequentially measures the current and voltage on the second terminal. The DUT Resistance value is measured easily by dividing the actual measured dropped voltage with the measured passing current through the DUT. The effective calculated measurement resolution of the DUT resistance value relied on the adjusted input range of the I2D. In low resistance value or high currents relative to the adjusted range, the resolution is limited by the analogue to digital converter (ADC) or digital to analogue converter (DAC). The I2D is limiting for high resistances or low currents [11].

### 3.5 NFC Data Exchange Format (NDEF) message

The main programming procedure of the NFC chip NHS3152 is done by NFC Data Exchange Format (NDEF) that it is a standardized data format compatible with ISO/IEC 14443-2 and ISO/IEC 14443-2 type A, which can be utilized to transfer and exchange data between any NFC reader and compatible NFC devices that are compatible with this protocol. The format of NDEF data is classified according to Messages and Records. The standard is established by the NFC Forum that is freely available for consultation but for requires must take a permission for downloading license[23]. The NFC Data Exchange Format (NDEF) format commonly is used to store and exchange data such as uniform resource identifier (URI), plain text, etc., utilizing a frequently known format. NFC chip like NHS3152 therapy adherence monitoring is configured as NDEF chips, and data registered to them by one LPC-Link 2 NFC device (NDEF Records) can be readable and classified by any other NDEF configured device. Obviously, in "peer-to-peer" mode, NDEF messages could also be utilized to exchange data between two compatible active NFC devices. So, practically by attaching to the NDEF data exchange format during the communication, devices that could have

common language or configured together are able to share and exchange data in an interactively method.

The messages of NDEF are defined as a basic transmission method for NDEF records that every message is consist of some NDEF Records. More specifically, NDEF Records consist of a special payload, and have the mentioned categorized structure that depicts the actual size and contents of the record as per chart 1:

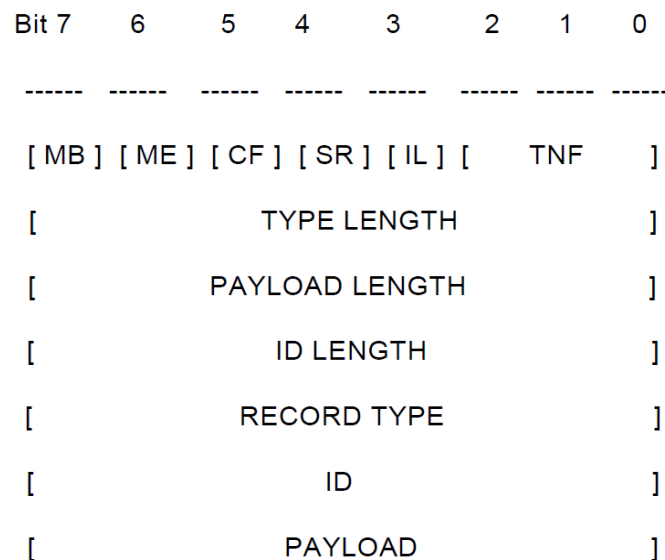

**Chart 1.** NDEF structure [23]

- TNF: Type Name Format Field or TNF Field of an NFC Data Exchange Format (NDEF) record is a 3-bit value by ability to explain the record type and adjust the expectation for the content and structure of the rest of the record.
- IL: ID length Field flag presented if the ID Length Field is shows or not. Generally, if this is set to 0, subsequently the ID Length Field is omitted in the record.
- SR: Short Record Bit flag is adjusted as 1 if the PAYLOAD LENGTH field is 1 byte or in some cases less. It is allowed extremely higher compact records.
- CF: Chunk Flag indicates the first record chunk is transmitted or it is an average record chunk.
- ME: Message End flag explains the last record is transmitted in the message or not.
- MB: Message Begin flag explains the start of an NDEF message transmitted or not.
- Type Length: Demonstrate the length in bytes of the Record Type field. Normally, this value is consistently 0 for specific types of records corresponding to the TNF Field.

- Payload Length: Shows the length in bytes of the record payload. In other word, if the SR field is adjusted to 1 in the record header, the value is one byte long (for a payload length from 0-255 bytes). If the SR field is adjusted to 0, this value will be a 32-bit value involving 4 bytes.
- ID Length: Specifies the length in bytes of the ID field. This field is depicted only if the IL flag (already explained) is set to 1 in the record header.
- Record Type: Generally, this value explains the 'type' of record that follows. The values of the type field must correspond to the value entered in the TNF bits of the record header.
- Record ID: The value of the ID field when an ID is considered, in the other word the IL bit in the record header is set to 1. When the IL bit is set to 0, this field is deleted.
- Payload: The record payload that is the number of bytes which described in the Payload Length field before [23].

In Figure 13 the sample of recorded measurement for resistance from NHS3152 NFC chip by android phone and NXP TagInfo application is shown.

The short description of application NDEF icon's titles are explained as per below:

- The NFC data set tag information clarifies message size and data set access to read and write the messages.
- The text record depicts encoding format of device and payload data by current values of measured resistance by android device.
- The NFC Data Exchange Format (NDEF) binary message format, was categorized to exchange application defined payloads of reader and chip between NFC devices.
- The NDEF capability container shows mapping version and maximum data size which was transmitted between devices. And finally, all messages are recorded in memory [25].

IC INFO	NDEF	EXTRA	FULL SCAN	IC INFO	NDEF	EXTRA	FULL SCAN
<b>NFC data set information</b> NDEF message containing 1 record Current message size: 36 bytes Maximum message size: 518 bytes NFC data set access: Read & Write Can be made Read-Only				<b>Technologies supported</b> ISO/IEC 14443-3 (Type A) compatible ISO/IEC 14443-2 (Type A) compatible			
<b>Record #1: Text record</b> Type Name Format: NFC Forum well-known type Short Record type: "T" encoding: UTF-8 lang: "en" text: "Current resistance: 380.52" Payload length: 32 bytes Payload data: [00] 02 65 6E 43 75 72 72 65   .enCurre  [08] 6E 74 20 72 65 73 69 73   nt resis  [10] 74 61 6E 63 65 3A 20 33   tance: 3  [18] 38 30 2E 35 32 00 00 00   80.52...				<b>Android technology information</b> Tag description: ▶ TAG: Tech [android.nfc.tech.NfcA, android.nfc.tech.MifareUltralight, android.nfc.tech.Ndef] ▶ Maximum transceive length: 253 bytes ▶ Default maximum transceive time-out: 618 ms			
<b>NDEF message</b> [00] D1 01 20 54 02 65 6E 43   .. T·enC  [08] 75 72 72 65 6E 74 20 72   urrent r  [10] 65 73 69 73 74 61 6E 63   esistanc  [18] 65 3A 20 33 38 30 2E 35   e: 380.5  [20] 32 00 00 00   2...				<b>Detailed protocol information</b> ID: 04:0D:74:00:12:28:03 ATQA: 0x4400 SAK: 0x00			
<b>NDEF Capability Container (CC)</b> Mapping version: 1.1 Maximum NDEF data size: 528 bytes				<b>Memory content</b> [00] * 04:0D:74 F5 (UID0-UID2, BCC0) [01] * 00:12:28:03 (UID3-UID6) [02] * 39 48 07 00 (BCC1, INT, LOCK0-LOCK1) [03] + E1:11:42:00 (OTP0-OTP3) [04] + 01 03 E8 0E   ....   [05] + 46 FD 01 00   F...   [06] + 03 24 D1 01   .\$. . .   [07] + 20 54 02 65   T·e   [08] + 6E 43 75 72   nCur   [09] + 72 65 6E 74   rent   [0A] + 20 72 65 73   res   [0B] + 69 73 74 61   ista   [0C] + 6E 63 65 3A   nce:   rrrr + 70 33 38 30   380			

Figure 13 NXP TagInfo NDEF data recorded for Resistance from NHS3152 chip

## 3.6 LPCXpresso C project

### 3.6.1 C programming procedure

C is a general progressed programming language which is popular, user-friendly and flexible. C language is machine-independent and structured programming language that is utilized extensively in various applications. It supports the full various operating systems (OS) and hardware platforms. Many different compilers such as Turbo C, are available for executing programs written in C language. A compiler is a special tool that could compile the program and makes it machine learner by converting it into the object file. After completing of the compilation process, the linker will mix different object files and generates a single executable file to run the main part as per Figure 14 for execution diagram of C program.

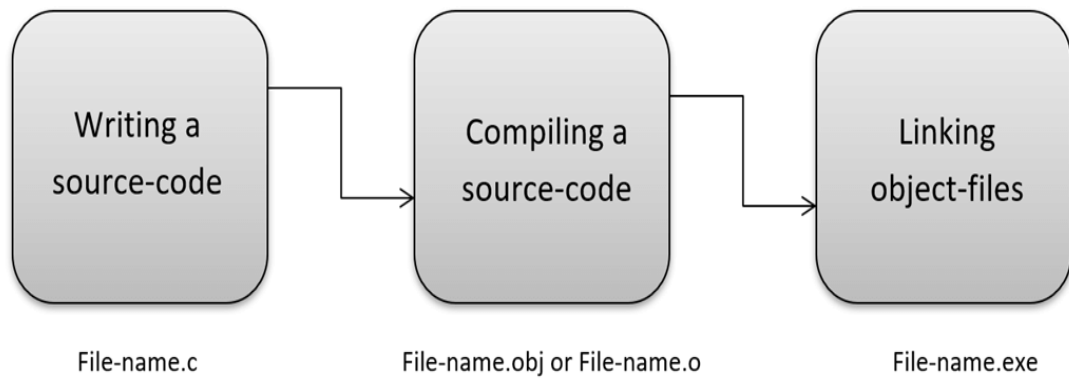

**Figure 14 C program execution diagrams**

In LPCXpresso IDE software by building a new project in NHS3152 chip and creating C platform to write and debug the written codes, the process of programming the chip is executed (Figure 15). An LPCXpresso IDE workspace is simply a directory which is utilized to save the projects that are currently working on them. Each Workspace is able to contain multiple sub projects, and it is possible to have multiple workplaces on personal computer. The LPCXpresso IDE could only have access to a single workplace at a same time; however, it is possible to run multiple illustrations in parallel with each one accessing a variety of workspaces. In general layout of the existing main LPCXpresso IDE window is known as a Perspective. Inside each Perspective, there are many sub-windows, called Views. The View shows a set of data in the LPCXpresso IDE environment. For example, this data may be source hex dumps, code, disassembly, or some time memory contents. Views can be opened, moved, loaded, and closed, and the layout of the currently depicted Views can be saved and restored. The major components of the LPCXpresso IDE Develop Perspective are Project Explorer / Peripherals / Registers Views, Editors, Console / Problems / Trace Views / Power Measurement, Quickstart / Variables / Breakpoints / Outlines / Expressions Views and debug view [24].

The sequence of creating new project is select the new project in Start Here menu, select C project of LPC437x, browse the library and select the desired NXP NHS3152 chip to perform programming on this platform.

After completing the programming procedure and building the new project, debugging the performed project is built the new Debug folder which contains the functional files to be flashed and used in different formats such as HEX, map etc.

```

mainresistance_read.c | @ adconv | @ adconvh | @ nsec
/** See system clock to NDEF, amount to suggest prints to terminal. */
83 Chip_Clock_System_SetClockFreq(4000000);
84
85 /** Board initialization. */
86 Board_Init();
87
88 /** Initialize NFC HW block. */
89 Chip_NFC_Init(NSS_NFC);
90
91 NDEF2T_Init();
92
93 /** To enable external readers to recognize the tag, NDEF formatting of the tag is required at start-up. */
94 if (false == CreateAndCommitEmptyMessage()) {
95 }
96
97
98
99 /**
100 * Function for NFC interrupt handling.
101 */
102 static void HandleNFC(void)
103 {
104     bool status = false;
105     if (RFFieldPresent()) { /** RF field present */
106         if (sMsgReady) {
107             sMsgReady = false;
108             status = ParseNDEFMessage();
109             if (status == false) {
110                 if (currentUseCase == USECASE_ADCVAL) {
111                     // Put Resistance Value into payload Text
112                     resval = get_ADConv();
113                     sprintf((char *)payloadText, "Current resistance: %4.2f", (float) resval);
114                     if (false == CreateAndCommitADConvMessage()) {}
115                 }
116             }
117         }
118     }
119 }
120 }
121
122 /**
123 * Function to create and commit an empty NDEF message for NDEF formatting.
124 * Return Propagates the return value of the NDEF2T_CommitMessage() from Ref MODS_NSS_NDEF2T "NDEF2T mod".
125 */

```

**Figure 15 LPCpresso IDE software**

The written C project program flow chart for measuring connected external resistance in LPCXpresso by NHS 3152 is categorized as per below and it is depicted in Chart 2 [11][26][27]:

1. Initiate NF\_C
2. Initiate Board
3. Initiate NDEF Type 2 Tag
4. Initiate ADC
5. Get resistance value
6. While loop:
  - a. Staying react NFC event.
    - i. If NFC present
      - 1) Put resistance value into 'payload Text'
      - 2) Prepare NDEF Message
      - 3) Commit it into shared memory

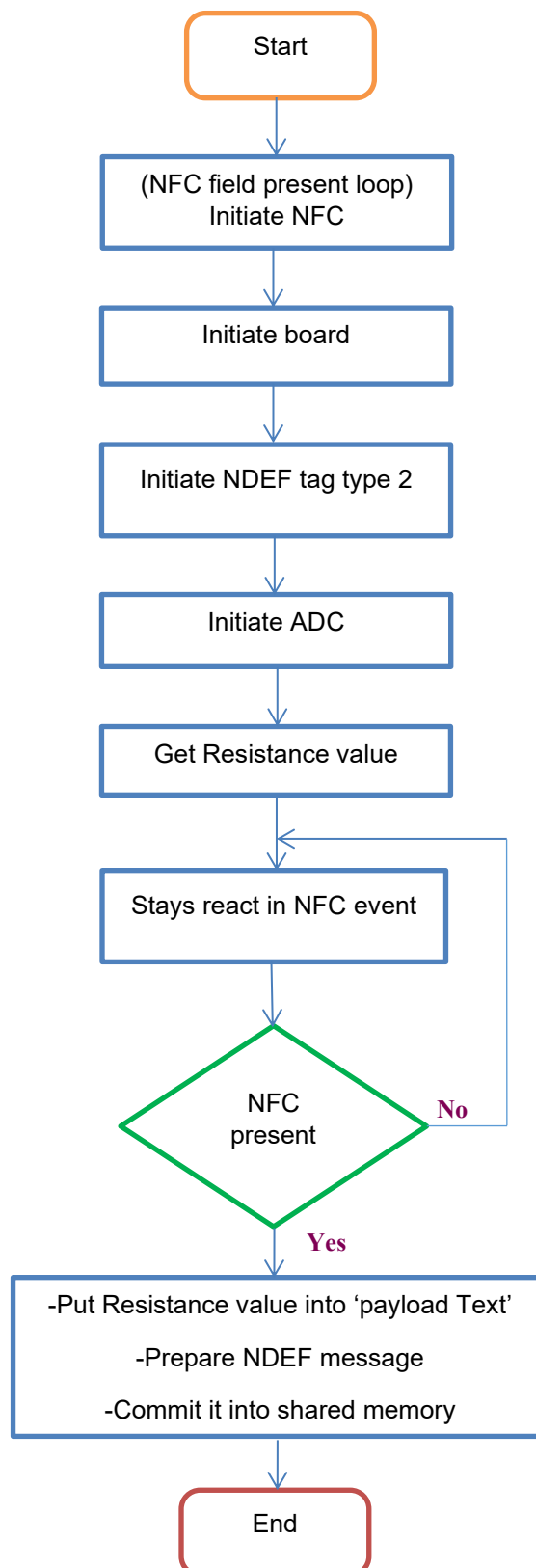

**Chart 2.** Flowchart of implemented C program in LPCXpresso

In addition, the main section of written program for this project is mentioned in Program 2.

```

/** Main **/
int main(void)
{
    Applnit();
    //Initiate ADC
    ADCconv_Init();
    //Get resistance

//    resval = get_ADCconv_I2D();
    while (true) {
        HandleNF_C();
    }
    * Function for driver and board initialization.
    */
void Applnit(void)
{
    /** Set system clock to 4MHz. needed to support prints to terminal. */
    Chip_Clock_System_SetClockFreq(4000000);

    /** Board initialization. */
    Board_Init();

    /** Initialize NFC HW block. */
    Chip_NF_C_Init(NSS_NF_C);

    NDEFT2T_Init();

    /** to enable external readers to recognize the tag, NDEF formatting of the tag is
    required at start-up. */
    if (false == CreateAndCommitEmptyMessage()) {
    }
}

```

**Program 2.** C codes for main section of project

### 3.6.2 Flashing procedure

The programming of NHS3152 to read and measure the Resistance on NFC field from LPC-link2 by creating LPCxpresso C project is implemented, built, debugged and hex format of data flashed to NHS3152 NXP by Flash Magic software (Figure 16).

It is PC software for programming flash-based microcontrollers by user friendly icons from NXP designed a serial or Ethernet protocol while in the target hardware.

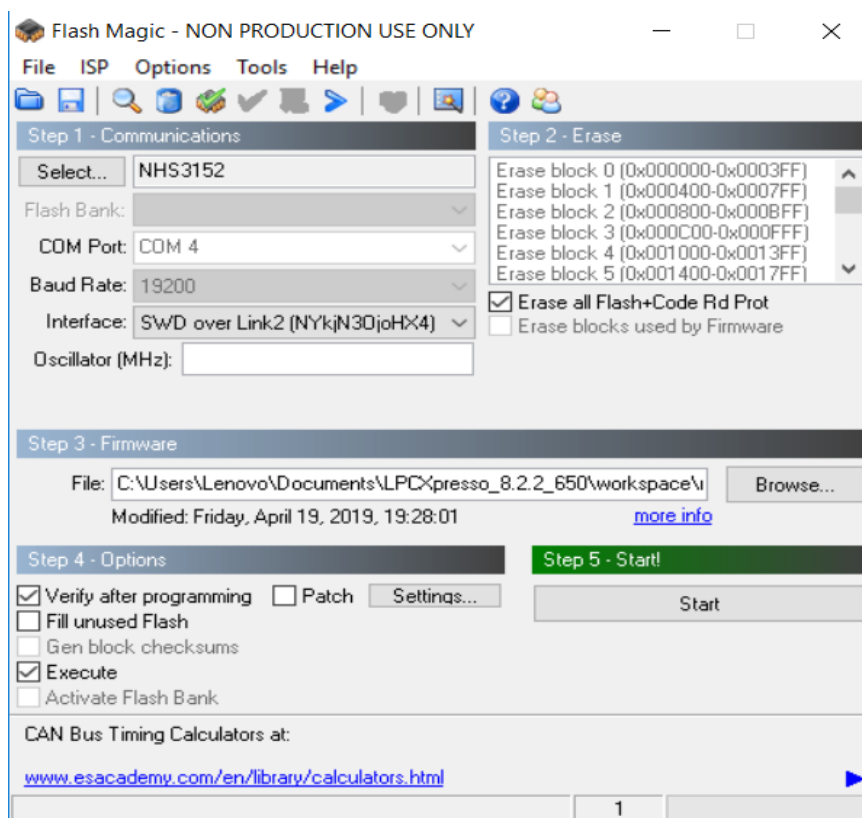

**Figure 16 Flashing the NHS3152 by Flash Magic software**

In Cortex-M, Serial Wire Debug (SWD) Interface is used by ARM for debug connections however; JTAG (hardware interface which provides the computer with a way to communicate directly with the chips on the electronic boards) is the classical mechanism for ARM7 or ARM9 parts. SWD over Link2 is the interface between the computer and NHS3152 chip from defined communication ports.

It is necessary that before launching Flash Magic, be sure the hardware of LPC-link2 is correctly connected as marked in Figure 17 and the following sequences should be done consequently:

1. Open the jumper over JP1.
2. A jumper must be closed and placed over JP2.
3. Connecting the LPC-Link2 board with PC using a mini-USB cable.

4. Connecting the demo PCB with the LPC-Link2 board using a JTAG cable.

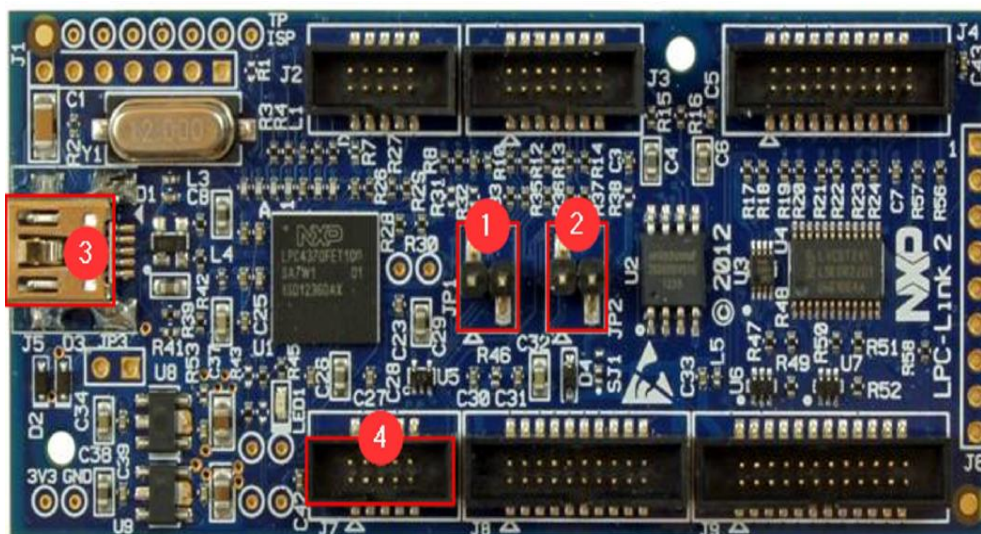

**Figure 17 Flashing procedure of NHS3152 by LPC Link2 board**

In software side, Graphical User Interface (GUI) Settings are implemented as per below procedure in Flash Magic software in Figure 16 and setting was done each time before trying to flash.

1. NHS3152 chip to program is selected.
2. The SWD over Link2 Interface is selected. Other non-important settings in the communications step are ignored.
3. Erase all Flash and codes sectors are selected.
4. Intel HEX format of files is selected from Browse section and the image scan with LPCXpresso file be obtained.
5. With the Execute checkbox ticked, the NHS3152 chip resets and starts executing the new firmware immediately after programming were done.
6. At the end, all settings are checked and clicked Start to carry out the requested operations [24].

## 4. RESULT AND ANALYSIS

In this chapter many circuits have been designed to reach the most trustable and equalized system to read resistance values. So, the result of them is analyzed by referring to written C program and circuit diagrams.

### 4.1 Resistance measurement applied methods

For measuring resistance values that are connected to analogue input pins of NHS3152, three methods are implemented in passive and active loop (battery free or with battery) to read the correct values in NXP TagInfo application by NDEF message from designed circuits.

#### 4.1.1 Resistance measurements based on NHS3152 passive loop

At the beginning it was tried to read Resistance values in fully passive ways by recommended circuit in NHS3152 data sheet. The connection is depicted as Figure 18 which AN0\_0 is defined as digital to analogue (DAC) pin and AN0\_3 set for current to digital or analogue to digital (I2D/ADC) one.

The device under test value is measured by dividing the actual measured dropped voltage with the measured passing current through the DUT.

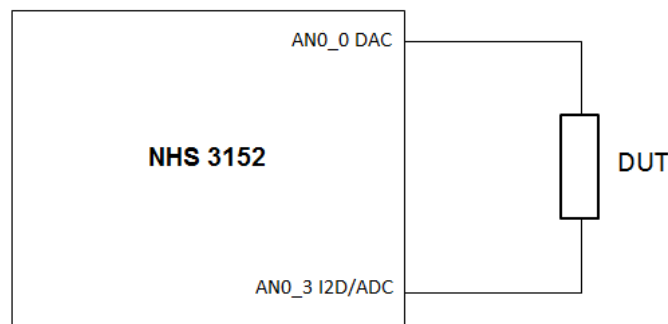

**Figure 18 Resistance measurement based on NHS3152 passive loop**

$$R_{DUT} = V_{ADC} / I_{I2D}, \quad (17)$$

For reading resistance correctly the pins are configured in LPCXpresso C programming language and written codes have been flashed correctly to NHS3152 chip. However, the DAC shows unstable results, and cannot drive output as configured. The definition and configuration of pins in LPCXpresso is depicted partly in Program 3.

```

/DAC output/
Chip_IOCON_SetPinConfig(NSS_IOCON, IOCON_ANA0_0, IOCON_FUNC_1);
/* Set pin function to analog */
Chip_ADCDAC_Init(NSS_ADCDAC0);
Chip_ADCDAC_SetMuxDAC(NSS_ADCDAC0, ADCDAC_IO_ANA0_0);
Chip_ADCDAC_SetModeDAC(NSS_ADCDAC0, ADCDAC_CONTINUOUS);
Chip_ADCDAC_WriteOutputDAC(NSS_ADCDAC0, 0XFFF);
Chip_ADCDAC_StartDAC(NSS_ADCDAC0);
IOCON_FUNC_0);
/* Set pin function to analog */

ADC_Init();
I2D_Init();

return true;
}

static void ADC_Init(){
    ADC Single-shot
    Chip_IOCON_SetPinConfig(NSS_IOCON, IOCON_ANA0_3,
IOCON_FUNC_1);
/* Set pin function to analog */
    Chip_ADCDAC_Init(NSS_ADCDAC0);
    Chip_ADCDAC_SetMuxADC(NSS_ADCDAC0, AN3);
Chip_ADCDAC_SetInputRangeADC(NSS_ADCDAC0, ADCDAC_INPUTRANGE_WIDE);
Chip_ADCDAC_SetModeADC(NSS_ADCDAC0, ADCDAC_SINGLE_SHOT);
}

static void I2D_Init(){
Chip_IOCON_SetPinConfig(NSS_IOCON, IOCON_ANA0_3, IOCON_FUNC_1);
/* Set pin function to analog */
Chip_I2D_Init(NSS_I2D);
Chip_I2D_Setup(NSS_I2D, I2D_SINGLE_SHOT, I2D_SCALER_GAIN_100_1,
I2D_CONVERTER_GAIN_LOW , 100);
Chip_I2D_SetMuxInput(NSS_I2D, I2D_INPUT_ANA0_3);
}

```

**Program 3.** C codes for resistance measurements by NHS3152 passive loop

For these reasons many modifications such as changing the analogue input pin and programming flowchart schedule have been done without any positive approaches. Therefore, I2D always read wrong value and completely out of range as per Table 4.

**Table 4.** Resistance measurement based on NHS3152 passive loop

CYCLE/DUT	DUT 10K OHM	DUT 1K OHM	DUT 400 OHM
1	8550	389	89
2	4001	442	2
3	5050	352	0
4	1005	330	0
5	4470	102	0
6	3580	211	43
7	2222	80	55
8	0	23	44
9	3456	0	23
10	1020	0	3

#### 4.1.2 Resistance measurements by voltage division

After implementing the passive loop (battery free) without any correct measuring values, the active loop is functioned for stabilizing the AN0\_3, I2D/ADC voltage. For this reason, the external VDDBAT (3 V dc, battery) voltage was powered the designed NHS3152 circuit as per Figure 19.

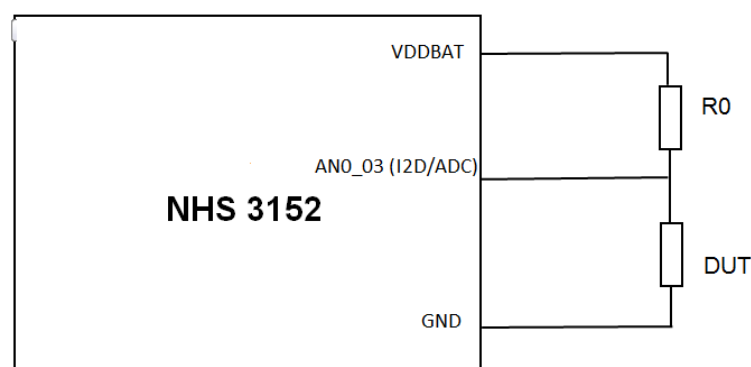

**Figure 19** Resistance measurements by voltage division

Voltage division method is used here to supply constant voltage over the device under test resistance as shown in equation 18;

$$R_{DUT} = \frac{V_{ADC} * R_0}{V_{DDBAT} - V_{ADC}} \quad , \quad (18)$$

Here R0 is adjusted resistance to implement voltage division circuit.

This shows more realistic, but the result is not stable because of voltage variation on device under test (DUT) that cannot drive the resistance continuously as per Table 5 (R0 is set by 3.9 k $\Omega$ ).

**Table 5.** Resistance measurements by voltage division

CYCLE\DUT	DUT 10K OHM	DUT 1K OHM	DUT 400 OHM
1	9805	705	130
2	7090	452	99
3	13090	290	53
4	3405	555	25
5	5520	386	45
6	3300	343	76
7	4909	434	40
8	2222	567	23
9	1020	760	12
10	988	223	0

In Program 4 the pins designation and description of them for voltage division designed circuit in LPCXpresso is depicted for AN0\_3 as analogue to digital converter (ADC) or current to digital (I2D).

The VDDBAT is assigned close to 3 V dc to be energized during the existent of NFC filed around NHS3152 chip immediately.

By reviewing NDEF message characteristic, the measurements are taken in single shot mode and discrete time. For this reason, the smartphone and tag should be close together during measurements of resistance. Enough time to configuration is passed and data transmission between tag and reader is completed.

```

static void ADC_Init(){
    //ADC Single-shot
    Chip_IOCON_SetPinConfig(NSS_IOCON, IOCON_ANA0_3,
    IOCON_FUNC_1); /* Set pin function to analog */
    Chip_ADCDAC_Init(NSS_ADCDAC0);
    Chip_ADCDAC_SetMuxADC(NSS_ADCDAC0, AN3);
    Chip_ADCDAC_SetInputRangeADC(NSS_ADCDAC0,
    ADCDAC_INPUTRANGE_WIDE);
    Chip_ADCDAC_SetModeADC(NSS_ADCDAC0,
    ADCDAC_SINGLE_SHOT);
}
static void I2D_Init(){
    Chip_IOCON_SetPinConfig(NSS_IOCON, IOCON_ANA0_3,
    IOCON_FUNC_1); /* Set pin function to analog */
    Chip_I2D_Init(NSS_I2D);
    Chip_I2D_Setup(NSS_I2D, I2D_SINGLE_SHOT,
    I2D_SCALER_GAIN_100_1, I2D_CONVERTER_GAIN_LOW , 100);
    Chip_I2D_SetMuxInput(NSS_I2D, I2D_INPUT_ANA0_3);
}

float get_ADCconv(){

    float res;
    int VDD_input = 3000; //Input voltage
    int r_0 = 3900; //Pull-up Resistor
    Chip_ADCDAC_StartADC(NSS_ADCDAC0);
    while (!(Chip_ADCDAC_ReadStatus(NSS_ADCDAC0) &
    ADCDAC_STATUS_ADC_DONE)) {
        ; /* Wait until measurement completes. For single-shot mode only! /
    }
    adclnput = ((float)Chip_ADCDAC_GetValueADC(NSS_ADCDAC0) *
    1600) / 4096;
    Chip_ADCDAC_DeInit(NSS_ADCDAC0);
    res = ((float)r_0 * adclnput) / ((float)VDD_input - adclnput);

    return res;
}

```

**Program 4.** C codes for pin definition of resistance measurements by voltage division

### 4.1.3 Resistance measurements by reference voltage

#### (Wheatstone bridge)

A Wheatstone bridge is a popular circuit utilized to measure an unknown electrical resistance by balancing two configured pin of a bridge circuit, one side of it includes the unknown component. The most benefit of this circuit is extremely high accurate measurement results.

As it is clear in Figure 20, for reaching the optimized and logical resistance measured values the  $ref\_r\_0$ ,  $ref\_r\_1$  and  $r\_0\_kohm$  (pull up resistance) are added to design Wheatstone bridge circuit as variables to stabilize the device under test voltage. AN0\_2 is defined as function pin and AN0\_3 for I2D/ADC to measure the resistance value accurately.

After calculating the voltages over  $ref\_r\_1$  and DUT, it is figured out that the reference constant and stable voltage drives those resistances every time as per equations (19) and (20).

$$V_{AN0\_2} = \frac{ref\_r\_1}{ref\_r\_1 + ref\_r\_0} V_{DDBAT} > 0, \quad (19)$$

$$V_{AN0\_3} = \frac{R_{DUT}}{ref\_0\_kohm + R_{DUT}} V_{DDBAT} > 0, \quad (20)$$

In more details,  $ref\_r\_0$ ,  $ref\_r\_1$  were set for getting reference voltage, because the input voltage is not stable at 3.0 Vdc.  $r\_0\_kohm$  is defined to divide voltage, because the ADC maximum range is 0-1.8 Vdc.

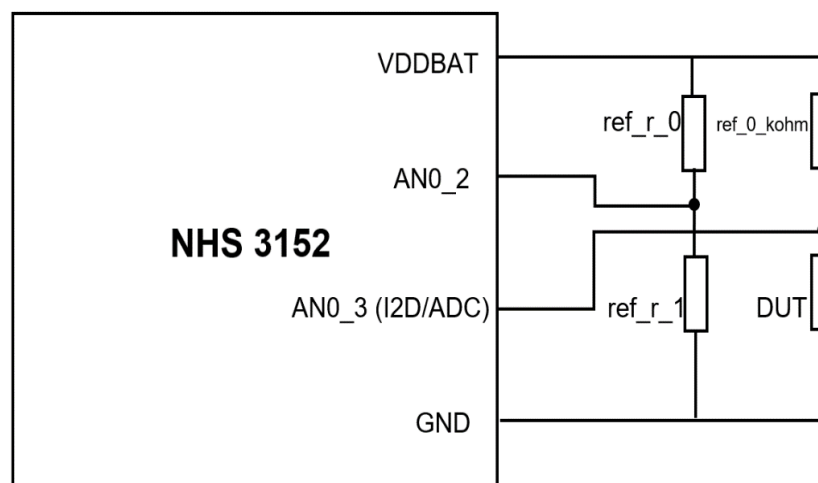

**Figure 20 Resistance measurements by reference voltage (Wheatstone bridge)**

In Table 6, the measured values by changing all parameters of circuit are depicted. As it is clear, the most correct measured Resistance for DUT 10 k $\Omega$  (9980 $\Omega$  real carbon resistance) for  $ref\_r\_0$ ,  $ref\_r\_1$  and  $r\_0\_kohm$  in 10 k $\Omega$ . In Figure 21 the histogram of 10 k $\Omega$  resistance measurements is depicted. It is depicted that, 60% of the values are 10236  $\Omega$  approximately

close to actual value (9980), 20% around 11018  $\Omega$  and others show different results. Furthermore, the average and accuracy values are calculated here by equation (21):

$$\text{Accuracy rate: } \frac{\Delta R(\text{real}-\text{average})}{R_{AVG}} = 1.35\%, \quad (21)$$

Average value ( $R_{AVG}$ ) = 10115.5 $\Omega$

**Table 6** Resistance measurements by reference voltage (Wheatstone bridge)

ref_r_0	ref_r_1	r_0_kohm	DUT 400	DUT 1K	DUT 10K
10K	10K	10K	103	986	9830
10K	10K	1K	412	96	2020
1K	10K	1K	812	360	-4090
1K	10K	10K	133	459	-1022

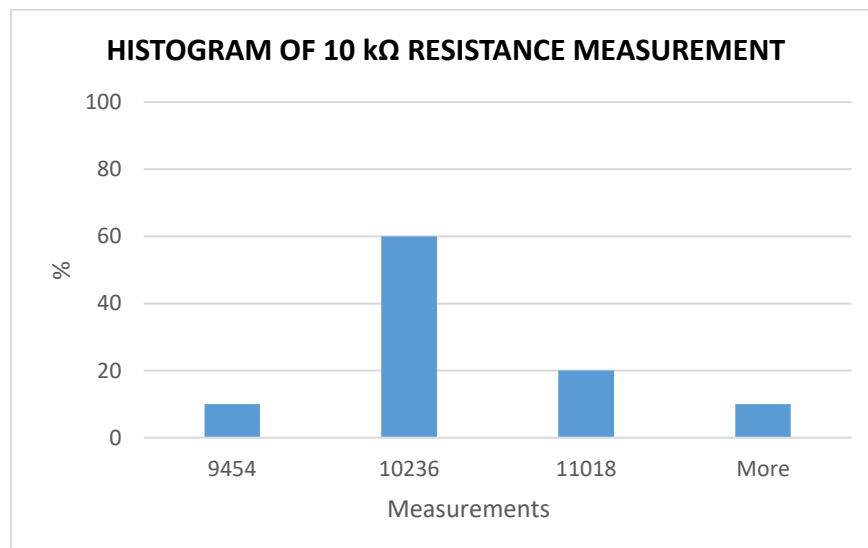

**Figure 21** Measured Resistance values for 10 k $\Omega$

For more explanations the Root Mean Square Error (RMSE) that measures how much error there is between two data sets is calculated. In other words, it compares a predicted value and an observed (equation (22)) [29].

$$\text{RMSE} = \sqrt{\frac{\sum_{i=1}^N (P_i - O_i)^2}{N}}, \quad (22)$$

Where,

$P_i$  is Predicted resistance value

$O_i$  is Observed resistance value

N, number of measurements,

After calculation RMSE value for measured 10 k $\Omega$  resistance values, the result is:

RMSE= 597.41.

Furthermore, for DUT 50 k $\Omega$  (variable resistor) by ref\_r\_0, ref\_r\_1 and r\_0\_kohm in 10 k $\Omega$ , three times separated measurements were taken as per Figure 22.

The values were recorded continuously by increasing potentiometer resistance from zero to maximum. In Figure 23, it is shown that the circuit is acting approximately linear between 4k $\Omega$  to 20 k $\Omega$  (linear region).

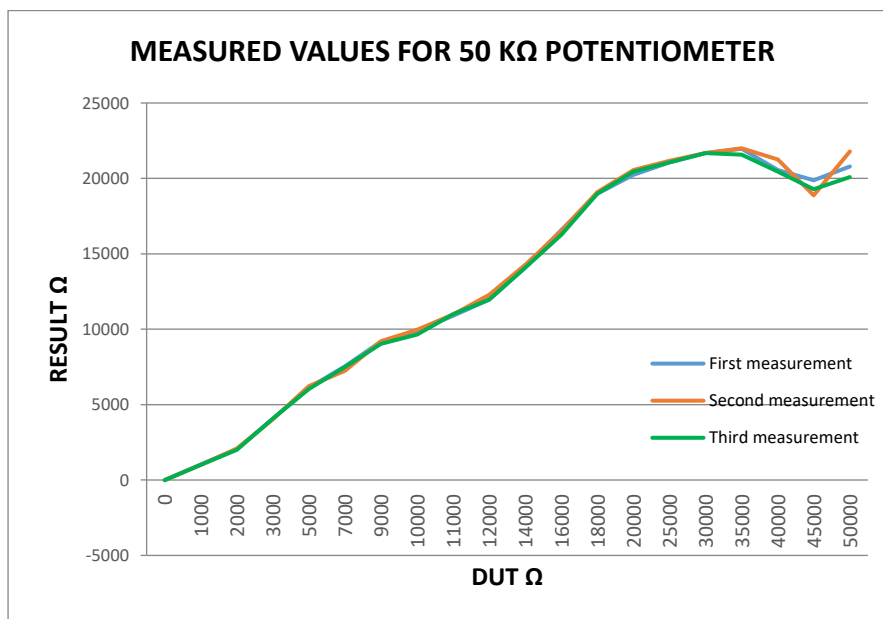

**Figure 22 Measured Resistance values for 50 k $\Omega$  potentiometer**

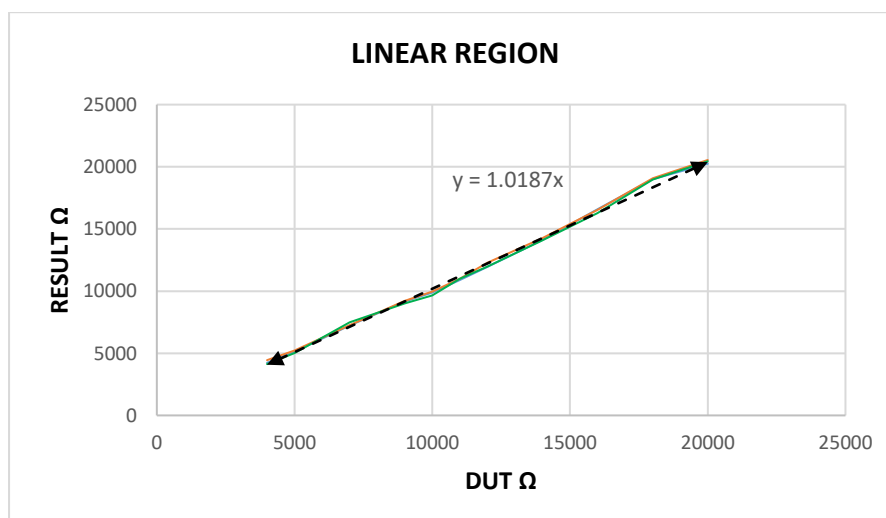

**Figure 23 Measured Resistance values for 50 k $\Omega$  potentiometer in linear region**

Program 5 is given below shows the pin configuration of resistance measurements by reference voltage (Wheatstone bridge) which has been explained completely to be specialized system by pinning layout. Clearly, AN0\_2 is defined as function pin and AN0\_3 for I2D/ADC to measure the resistance value accurately.

```

static void ADC_Init(){
    //ADC Single-shot
    Chip_IOCON_SetPinConfig(NSS_IOCON, IOCON_ANA0_3,
    IOCON_FUNC_1);
    /* Set pin function to analogue */
    Chip_ADCDAC_Init(NSS_ADCDAC0);
    Chip_ADCDAC_SetMuxADC(NSS_ADCDAC0, AN3);
    Chip_ADCDAC_SetInputRangeADC(NSS_ADCDAC0,
    ADCDAC_INPUTRANGE_WIDE);
    Chip_ADCDAC_SetModeADC(NSS_ADCDAC0,
    ADCDAC_SINGLE_SHOT);
}
static void ADC_REF_Init(){
    //ADC Single-shot
    Chip_IOCON_SetPinConfig(NSS_IOCON, IOCON_ANA0_2,
    IOCON_FUNC_1);
    /* Set pin function to analogue */
    Chip_ADCDAC_Init(NSS_ADCDAC0);
    Chip_ADCDAC_SetMuxADC(NSS_ADCDAC0, AN2);
    Chip_ADCDAC_SetInputRangeADC(NSS_ADCDAC0,
    ADCDAC_INPUTRANGE_WIDE);
    Chip_ADCDAC_SetModeADC(NSS_ADCDAC0,
    ADCDAC_SINGLE_SHOT);
}
static void I2D_Init(){
    //Chip_IOCON_SetPinConfig(NSS_IOCON, IOCON_ANA0_3, IOCON_FUNC_1); /*
    Set pin function to analogue */
    Chip_I2D_Init(NSS_I2D);
    Chip_I2D_Setup(NSS_I2D, I2D_SINGLE_SHOT,
    I2D_SCALER_GAIN_100_1, I2D_CONVERTER_GAIN_LOW , 100);
    Chip_I2D_SetMuxInput(NSS_I2D, I2D_INPUT_ANA0_3);
}

```

**Program 5.** C codes pin definition for resistance measurement by reference voltage

## 4.2 Wheatstone bridge sensitivity

The sensitivity can be expressed as output voltage  $\Delta E_{AN23}$  in relation with change of resistance in one of bridge arms with compare to DUT as per below equation (23) [30]:

$$\frac{\Delta E_{AN23}}{\Delta R_{DUT}} = \frac{V_{DDBAT} \text{ ref\_r\_1}}{(ref_{r_1} + R_{DUT})^2} , \quad (23)$$

So, for DUT 50 k $\Omega$  (variable resistor) by ref\_r\_0, ref\_r\_1 and r\_0\_kohm ( pull up resistance) in 10 k $\Omega$  the measurements was taken in linear region between 4 to 20 k $\Omega$  and the sensitivity curve is plotted as per Figure 24.

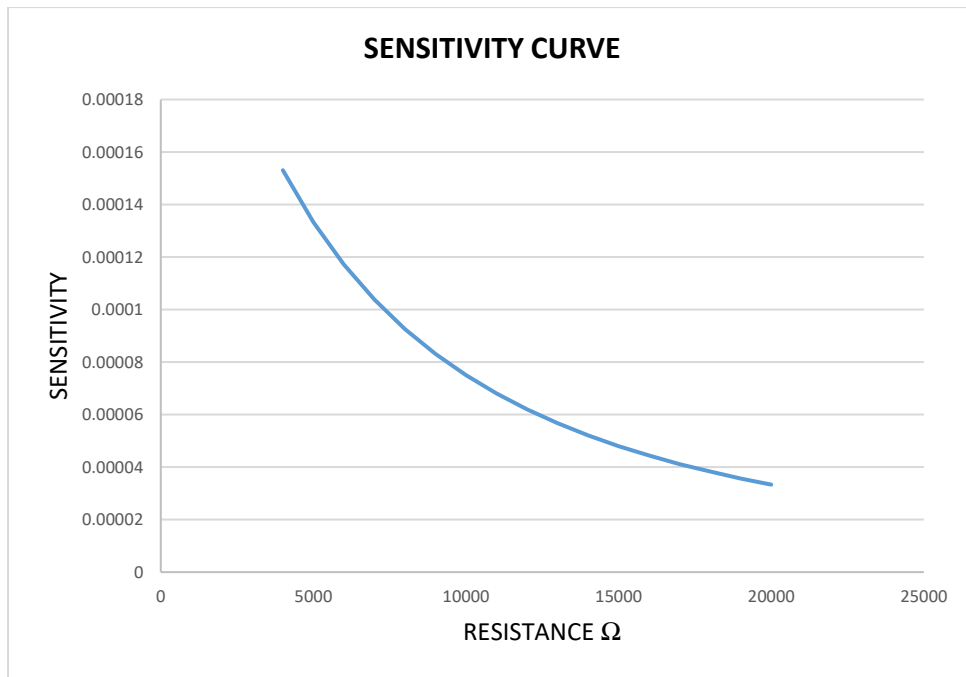

**Figure 24 Wheatstone bridge sensitivity curve in linear region of designed circuit**

For  $R_{DUT}$  equal to ref\_r\_1, the equation (23) could be written as below by equation (24) and expressed as change in resistance value per DUT resistance [30][31]:

$$\frac{\Delta R_{DUT}}{R_{DUT}} = \frac{4 E_{AN23}}{V_{DDBAT}} , \quad (24)$$

By considering the above equation, it is simple to calculate the sensitivity value for 10 k $\Omega$  resistance as per below:

$$R_{DUT} = 10 \text{ k}\Omega \rightarrow E_{AN23} = 200 \text{ mV} , \quad \frac{\Delta R_{DUT}}{R_{DUT}} = \frac{4 E_{AN23}}{V_{DDBAT}} = 0.26$$

### 4.3 Analysing of screen-printed stretchable carbon interconnects

Regarding to high development of the wearable electronic applications especially in healthcare components that high stretchable potential, flexibility and conductivity of materials is key point to fabricate a new device, the stretchable interconnects using deformable materials was fabricated in form of carbon ink and thermoplastic polyurethane by Finnseri Oy as per Figure 25. The static resistance of interconnects were on average  $296 \Omega/\text{square}$ , and half of the samples withstood single strain up to 108 % elongation which it defines as the amount of extension in materials under stress, that usually expressed as some percentage of the original length and the resistance change is more or less linear up to 50% (linear region) of large deformation for skin [32].

The matching of screen-printed stretchable carbon interconnects with designed resistance circuit by reference voltage (Wheatstone bridge) in section 4.1 of this thesis based on NFC NHS3152 is done subsequently.

The results show that the sensor by minimum length of 15-20 (4.5-6 k $\Omega$ ) could be measured by stretching to 20 k $\Omega$  dynamic range.

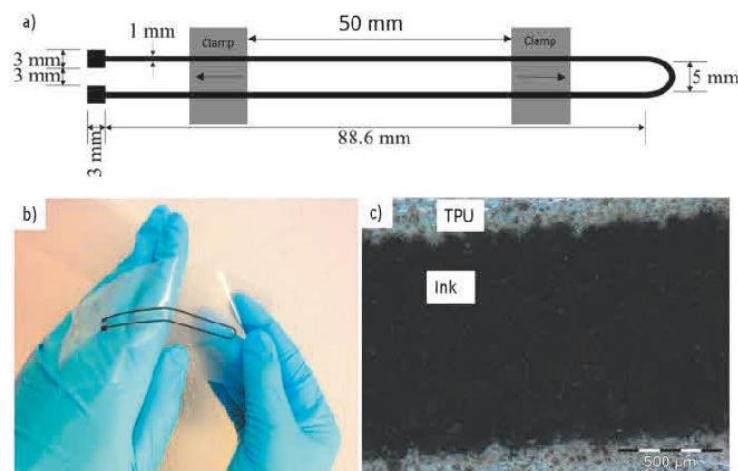

**Figure 25 Screen-printed stretchable carbon interconnects [32]**

## 5. CONCLUSIONS

In this project had been tried to use NFC energy harvesting properties to connect, measure and evaluate an external resistance sensor in analogue input such as printed on skin sensor that could be completely practical device under test to be used in different field of technology. The NFC based chip was applied and programmed here is NHS3152 NXP manufactured therapy adherence with starter kit LPC-Link 2 that connected the personal computer to NFC chip to implement written program on chip. LPCXpresso and Flash Magic are the main software to program, build, debug and flash the NFC NXP chip by usage of C programming language and NFC data exchange format (NDEF) message to read the tag by android smartphones.

The NFC TagInfo application has been utilized to measure and log the actual values of device under test which were connected to device by applying NDEF message and by android smart phones.

In experiments, NHS3152 internal temperature sensor was programmed and the actual ambient temperature has been recorded in fully passive loop by NFC TagInfo and the result was satisfying by comparing to external existing temperature sensor.

The main part of thesis was recording an external resistance such as flexible printed resistance sensor by NHS3152. The device under test has been set in many different circuits to measure the most accurate values by android smartphone. By putting DUT in resistance measurements based on NHS3152 passive loop (by referring to NHS3152 data sheet) the result was not stable and measured values were fluctuating in passive circuit during taking many discrete measurements. For this reason, other circuits such as voltage division by external battery, were designed to reach the best results and finally by using external battery and in Wheatstone bridge by reference voltage circuit the measured values were considerably accurate in linear region by sensitivity close to 0.26 and accuracy rate of 1.35% (for 10 k $\Omega$  device under test).

It is clear that, this field of technology would be progressed a lot in future where day by day the new component and gadget for human body, healthcare and other Internet of Things (IoT) applications especially wearable/ flexible ones are invented and the electronic companies try to satisfy their customers by publishing new technologies.

There could be established many projects to use the NFC chip for measuring and logging analogue values of different type of on skin sensors by implementing energy harvesting and it is more user friendly to electronic industrial field by reaching the most practical gadgets especially to help doctors to be aware of their patients critical signs of body easily and constantly.

## REFERENCES

- [1] P. Escobedo, M. M. Erenas, N. Lopez-Ruiz, M. A. Carvajal, S. Gonzalez- Chocano, I. de Orbe-Paya, L. F. Capitan-Valley, A. J. Palma, and A. Martinez-Olmos "Flexible Passive near Field Communication Tag for Multigas Sensing", *Analytical Chemistry*, Vol.89, no.3, pp.1697-170,2017.
- [2] Dobriyal, Pariva, Ashi Qureshi, Ruchi Badola, and Syed Ainul Hussain."A review of the methods available for estimating soil moisture and its implications for water resource management", *Journal of Hydrology*, Vol. 458, pp 110-117, 2012.
- [3] ST Application note AN2866, "How to design a 13.56 MHz customized tag antenna", Revision 1, January 2009.
- [4] Zargham, M.; Gulak, P.G. Maximum Achievable Efficiency in Near-Field Coupled Power-Transfer Systems. *IEEE Trans. Biomed. Circ. Syst.* 2012, 6, 228–245
- [5] M. Gebhart, S. Bimstingl, J. Bruckbauer, E. Merlin, "Properties of a test bench to verify standard compliance of proximity transponders", 2008 6th International Symposium on Communication Systems Networks and Digital Signal Processing, pp. 306-310, 2008
- [6] Dehennis, Andrew David, Marko Mailand, David Grice, Stefan Getzlaff, and Arthur E. Colvin. "A near-field-communication (NF\_C) enabled wireless fluorimeter for fully implantable biosensing applications." In *Solid-State Circuits Conference Digest of Technical Papers (ISSCC)*, 2013 IEEE International, pp. 298-299. IEEE, 2013.
- [7] P. Escobedo, M. M. Erenas, N. López-Ruiz, M. A. Carvajal, S. Gonzalez-Chocano, I. de Orbe-Paya, L. F. Capitán-Valley, A. J. Palma, A. Martínez-Olmos, "Flexible Passive near Field Communication Tag for Multigas Sensing", *Analytical Chemistry*, vol. 89, no. 3, pp. 1697-170, 2017
- [8] Kassal, Petter, Ivanka Murkovic and Matthew D. Steinberg potentiometric input for ultra-low-power chemical sensing." *Sensors and Actuators B: Chemical* 184 (2013): 254-259.
- [9] "Principle of data acquisition and converter" Texas Instrument. April 2015, retrieved 2016-10-18
- [10] <https://www.jtag.com/>
- [11] <https://www.nxp.com/docs/en/data-sheet/NHS3152.pdf>
- [12] Paret, D. *Design Constraints for NFC Devices*; John Wiley & Sons Inc.: Hoboken, NJ, USA, 2016; ISBN 9781848218840.
- [13] Finkenzeller, Klaus. "Physical principles of RFID systems." *RFID Handbook: Fundamentals and Applications in Contactless Smart Cards, Radio Frequency Identification and near-Field Communication*, Third Edition (2010): 61-154.
- [14] ST Application note AN2866, "How to design a 13.56 MHz customized tag antenna", Revision 1, January 2009.

- [15] Zargham, M.; Gulak, P.G. Maximum Achievable Efficiency in Near-Field Coupled Power-Transfer Systems. *IEEE Trans. Biomed. Circ. Syst.* 2012, 6, 228–245.
- [16] Finkenzeller, K.; Müller, D. *RFID Handbook: Fundamentals and Applications in Contactless Smart Cards, Radio*
- [17] Yeager, Daniel, Fan Zhang, Azin Zarrasvand, Nicole T. George, Thomas Daniel, and Brian P.Otis. "A 9 a, addressable gen2 sensor tag for biosignal acquisition." *Solid-State Circuits, IEEE Journal of* 45, no. 10 (2010): 2198-2209.
- [18] Finkenzeller, Klaus. "Physical principles of RFID systems." *RFID Handbook: Fundamentals and Applications in Contactless Smart Cards, Radio Frequency Identification and near-Field Communication, Third Edition* (2010): 61-154.
- [19] Antonio Lazaro, Ramon Villarino and David Girbau, A Survey of NFC Sensors Based on Energy Harvesting for IoT Applications, Department of Electronic, Electric and Automatic Control Engineering, Universitat Rovira i Virgili, 2018
- [20] *Beginning NFC* by Brian Jepson, Don Coleman, Tom Igoe, O'Reilly Media, Inc, 2017
- [21] K. Takei, W. Honda, S. Harada, T. Arie, S. Akita, toward flexible and wearable human-interactive health-monitoring devices. *Adv. Healthcare Mater.* 4, 487–500 (2015).
- [22] T. Yokota, Y. Inoue, Y. Terakawa, J. Reeder, M. Kaltenbrunner, T. Ware, K. Yang, K. Mabuchi, T. Murakawa, M. Sekino, W. Voit, T. Sekitani, T. Someya, Ultraflexible, large-area, physiological temperature sensors for multipoint measurements. *Proc. Natl. Acad. Sci. U.S.A.* 112, 14533–14538 (2015).
- [23] [https://learn.adafruit.com/adafruit-pn532-rfid-nf\\_c/ndef](https://learn.adafruit.com/adafruit-pn532-rfid-nf_c/ndef)
- [24] The LPCXpresso IDE and the Arm Cortex M0, <https://www.nxp.com/>
- [25] [https://learn.adafruit.com/adafruit-pn532-rfid-nf\\_c/ndef](https://learn.adafruit.com/adafruit-pn532-rfid-nf_c/ndef)
- [26] *C Programming Language, 2nd Edition* 2nd Edition, by Brian W. Kernighan, Dennis M. Ritchie, Prentice Hall; 2 edition (April 1, 1988)
- [27] *Programming in C (3rd Edition)* 3rd Edition by Stephen G. Kochan, Sams Publishing; 3 edition (July 18, 2004)
- [28] [https://www.asiarfid.com/rfid-journal/nf\\_c-facts-and-applications-that-will-broaden-your-mind.html](https://www.asiarfid.com/rfid-journal/nf_c-facts-and-applications-that-will-broaden-your-mind.html)
- [29] <https://gisgeography.com/root-mean-square-error-rmse-gis/>
- [30] John W. Mcwane, Wheatstone bridge - Brown University Wiki, 1981
- [31] *Wheatstone Bridge*, Jesse Russell, Ronald Cohn, Book on Demand, 2012
- [32] Mahmoud Mosallaei, Behnam Khorramdel, Mari Honkanen, Pekka Iso-Ketola, Jukka Vanhala, Matti Mäntysalo, *Fabrication and Characterization of Screen-Printed Stretchable Carbon Interconnects*, 2017

## APPENDIX A: WRITTEN C CODES IN LPCXPRESSO

```

#include <string.h>
#include <stdlib.h>
#include <stdio.h>
#include "board.h"
#include "ndeft2t/ndeft2t.h"

#include "./adconv/adconv.h"
/*
 * adconv.h
 *
 */

#ifndef ADCCONV_ADCCONV_H_
#define ADCCONV_ADCCONV_H_

#include "chip.h"

#define AN0  ADCDAC_IO_ANA0_0
#define AN1  ADCDAC_IO_ANA0_1
#define AN2  ADCDAC_IO_ANA0_2
#define AN3  ADCDAC_IO_ANA0_3
#define AN4  ADCDAC_IO_ANA0_4
#define AN5  ADCDAC_IO_ANA0_5

bool ADCconv_Init();
float get_ADCconv();
float get_ADCconv_I2D();

#endif /* ADCCONV_ADCCONV_H_ */

const uint8_t locale[] = "en"; /** TEXT record locale. */
uint8_t payloadText[30]; /** TEXT record payload. */

//Store Resistance value
volatile float resval = -1;

/** Data structure for the NDEFT2T mode */

```

```

uint8_t instanceBuffer[NDEFT2T_INSTANCE_SIZE];
/** Instance buffer shared for NDEF read and write operation */
uint8_t messageBuffer[NF_C_SHARED_MEM_BYTE_SIZE];
/** Message buffer for NDEF */

/** Variables used for Case management */
typedef enum USECASE {
    USECASE_ADCVAL
} USECASE_T;

static USECASE_T currentUseCase = USECASE_ADCVAL;
/** indicates the current use case */
/** Variables used for tracking interrupts. */
static volatile bool RFFieldPresent = false;
/** Flag indicating presence of the RF field */
static volatile bool sMsgReady = false;
/** Flag indicating a valid NDEF message in shared memory */

/** Function for driver and board initialization. */
static void Applnit(void);

/** Function for NFC interrupt handling. */
static void HandleNF_C(void);

/** Function to create and commit an empty NDEF message for NDEF formatting. */
static bool CreateAndCommitEmptyMessage(void);

/** Function to combine all steps for NDEF message (with TEXT and MIME records) creation
and commit. */
static bool CreateAndCommitADCMIMEMessage(void);

/** Function to handle all steps for NDEF Message parsing from shared memory. */
static bool ParseNDEFMessage(void);

/** define NDEFT2T Call back */
/** Call back from NDEFT2T MOD. Refer #NDEFT2T_FIELD_STATUS_CB. */
void NDEFT2T_FieldStatus_Cb(bool status)
{
    RFFieldPresent = status;
}

```

```

/** Call back from NDEFT2T MOD. Refer #NDEFT2T_MSG_AVAILABLE_CB. */
void NDEFT2T_MsgAvailable_Cb(void)
{
    sMsgReady = true;
}

/** Main **/
int main(void)
{
    ApplInit();
    //Initiate ADC
    ADCconv_Init();
    //Get resistance

//    resval = get_ADCconv_I2D();
    while (true) {
        HandleNF_C();
    }

    return 0;
}

/*****
* Private functions
*****/

/**
* Function for driver and board initialization.
*/
void ApplInit(void)
{
    /** Set system clock to 4MHz. needed to support prints to terminal. */
    Chip_Clock_System_SetClockFreq(4000000);

    /** Board initialization. */
    Board_Init();

    /** Initialize NFC HW block. */
    Chip_NF_C_Init(NSS_NF_C);

```

```

NDEFT2T_Init();

/** to enable external readers to recognize the tag, NDEF formatting of the tag is required
at start-up. */
    if (false == CreateAndCommitEmptyMessage()) {
    }
}

/** Function for NFC interrupt handling.*/
static void HandleNF_C(void)
{
    bool status = false;
    if (RFFieldPresent) { /** RF field present */
        if (sMsgReady) {
            sMsgReady = false;
            status = ParseNDEFMessage();
            if (status == false) {
            }
        }
    }
    if(currentUseCase == USECASE_ADCVAL){
        // Put Resistance Value into payload Text
        resval = get_ADCconv();
        sprintf((char *)payloadText, "Current resistance: %4.2f", (float)(resval));
        if (false == CreateAndCommitADCMIMEMessage()) {
        }
    }
}
}

/**
 * Function to create and commit an empty NDEF message for NDEF formatting.
 * @return Propagates the return value of the NDEFT2T_Commit Message () from @ref
MODS_NSS_NDEFT2T "NDEDT2T mod".
 * @note Refer to @ref MODS_NSS_NDEFT2T.NDEFT2T_CommitMessage for additional
tag information.
 */
static bool CreateAndCommitEmptyMessage(void)
{
    /** creates an NDEF message */

```

```

NDEFT2T_CreateMessage((void*)instanceBuffer,messageBuffer,
NF_C_SHARED_MEM_BYTE_SIZE, true);

/** Finish the NDEF processing and commit generated message to shared memory. */
return NDEFT2T_CommitMessage((void*)instanceBuffer);
}

/**
 * Function to combine all steps for NDEF message (with TEXT and MIME records) creation
and commit.
 * @return Propagates the return value of the NDEFT2T_Commit Message () from @ref
MODS_NSS_NDEFT2T "NDEFT2T mod".
 * @note Refer to @ref MODS_NSS_NDEFT2T.NDEFT2T_CommitMessage for additional
tag information.
 */
static bool CreateAndCommitADCMIMEMessage(void)
{
    NDEFT2T_CREATE_RECORD_TAGINFO_T recordTagInfo;
    bool status;

    (void) status;
    /* suppresses unused warning in release build (due to ASSERT statements which are
removed) */
    /** creates an NDEF message */
    NDEFT2T_CreateMessage((void*)instanceBuffer, messageBuffer,
NF_C_SHARED_MEM_BYTE_SIZE, true);

    /** create a Text record */
    recordTagInfo.shortRecord = true; /** Enable Short Record. */
    recordTagInfo.pString = (uint8_t *)locale; /** Assign language code. */
    status = NDEFT2T_CreateTextRecord((void*)instanceBuffer, &recordTagInfo);
    ASSERT(status);

    /** NULL terminator excluded for size parameter */
    status = NDEFT2T_WriteRecordPayload((void*)instanceBuffer, (void *)payloadText,
(sizeof(payloadText) - 1));
    ASSERT(status);
    NDEFT2T_CommitRecord((void*)instanceBuffer);

    /** Finish the NDEF processing and commit generated message to shared memory. */

```



```

        break;
    case NDEFT2T_RECORD_TYPE_EMPTY:
        /** Print EMPTY record. */

        break;
    default:
        /** do nothing. */

        break;
    }
}
}
return status;
}

/*
 * adconv.c
 * Set pins function */
*/

#include <string.h>
#include <stdlib.h>

#include "board.h"
#include "adconv.h"

static void ADC_Init();
static void I2D_Init();

bool isReady = false;
float adcInput;

static void ADC_Init(){
    //ADC Single-shot
    Chip_IOCON_SetPinConfig(NSS_IOCON, IOCON_ANA0_3,
    IOCON_FUNC_1);
    /** Set pin function to analogue */

```

```

    Chip_ADCDAC_Init(NSS_ADCDAC0);
    Chip_ADCDAC_SetMuxADC(NSS_ADCDAC0, AN3);
    Chip_ADCDAC_SetInputRangeADC(NSS_ADCDAC0,
ADCDAC_INPUTRANGE_WIDE);
    Chip_ADCDAC_SetModeADC(NSS_ADCDAC0, ADCDAC_SINGLE_SHOT);
}

```

```

static void ADC_REF_Init(){
    //ADC Single-shot
    Chip_IOCON_SetPinConfig(NSS_IOCON, IOCON_ANA0_2,
    IOCON_FUNC_1);
    /* Set pin function to analogue */
    Chip_ADCDAC_Init(NSS_ADCDAC0);
    Chip_ADCDAC_SetMuxADC(NSS_ADCDAC0, AN2);
    Chip_ADCDAC_SetInputRangeADC(NSS_ADCDAC0,
ADCDAC_INPUTRANGE_WIDE);
    Chip_ADCDAC_SetModeADC(NSS_ADCDAC0, ADCDAC_SINGLE_SHOT);
}

```

```

static void I2D_Init(){
    //Chip_IOCON_SetPinConfig(NSS_IOCON, IOCON_ANA0_3, IOCON_FUNC_1); /* Set pin
    function to analogue */
    Chip_I2D_Init(NSS_I2D);
    Chip_I2D_Setup(NSS_I2D, I2D_SINGLE_SHOT,
I2D_SCALER_GAIN_100_1, I2D_CONVERTER_GAIN_LOW, 100);
    Chip_I2D_SetMuxInput(NSS_I2D, I2D_INPUT_ANA0_3);
}

```

```

float get_ADCconv(){

    float res;
    float vss_input = 3300;

    //Input voltage
    /** output in  $\mu\text{V}$  = ((native value - native offset) * internal operating voltage / steps per  $\mu\text{V}$ ) +
    offset
    * native offset = 2048
    * internal voltage = 1.2V
    * gain (steps per  $\mu\text{V}$ ) = 2730
    * offset = 0.9V **/

```

```

float r_0_kohm = 10000; //Pull-up Resistor
int ref_r_0 = 10000;
int ref_r_1 = 10000;

// calibrate Voltage reference
ADC_REF_Init();
Chip_ADCDAC_StartADC(NSS_ADCDAC0);
while      (!(Chip_ADCDAC_ReadStatus(NSS_ADCDAC0)      &
ADCDAC_STATUS_ADC_DONE)) {
    ; /* Wait until measurement completes. For single-shot mode only! */
}
adclnput  = (((float)(Chip_ADCDAC_GetValueADC(NSS_ADCDAC0) -
2048))*1.2) / 2730 + 0.9);
vss_input = ((float)(ref_r_1 + ref_r_0)/(float)(ref_r_1)) * adclnput;

ADC_Init();
Chip_ADCDAC_StartADC(NSS_ADCDAC0);
while      (!(Chip_ADCDAC_ReadStatus(NSS_ADCDAC0)      &
ADCDAC_STATUS_ADC_DONE)) {
    ; /* Wait until measurement completes. For single-shot mode only! */
}
adclnput  = (((float)(Chip_ADCDAC_GetValueADC(NSS_ADCDAC0) -
2048))*1.2) / 2730 + 0.9);
res = ((float)r_0_kohm * adclnput)/ ((float)vss_input - adclnput);

return res;
}

```

```

float get_ADCconv_I2D(){

    int i2dValue;
    int i2dNativeValue;
    float res;

//      Chip_ADCDAC_StartDAC(NSS_ADCDAC0);

    Chip_ADCDAC_StartADC(NSS_ADCDAC0);
    while      (!(Chip_ADCDAC_ReadStatus(NSS_ADCDAC0)      &
ADCDAC_STATUS_ADC_DONE)) {
        ; /* Wait until measurement completes. For single-shot mode only! */
    }
}

```

```
    }
    adcInput = ((float)Chip_ADCDAC_GetValueADC(NSS_ADCDAC0) * 1600) /
4096;
    Chip_ADCDAC_DeInit(NSS_ADCDAC0);

    Chip_I2D_Start(NSS_I2D);
    while (!(Chip_I2D_ReadStatus(NSS_I2D) & I2D_STATUS_CONVERSION_DONE)) {
        ; /* wait */
    }

    i2dNativeValue = Chip_I2D_GetValue(NSS_I2D);
    i2dValue = Chip_I2D_NativeToPicoAmpere(i2dNativeValue, I2D_SCALER_GAIN_100_1,
I2D_CONVERTER_GAIN_LOW, 100);

    // Chip_ADCDAC_StopDAC(NSS_ADCDAC0);
    // Chip_ADCDAC_DeInit(NSS_ADCDAC0);
    // Chip_I2D_DeInit(NSS_I2D);
    res = (adcInput / (float)i2dValue) * 1000000000;
    return res;
}
```