

Textile in Architecture

Master's Thesis

Terhi Kristiina Kuusisto

Tampere University of Technology

Master's Degree Programme in Architecture



Terhi Kristiina Kuusisto

Textile in Architecture
Arkkitehtuurin tekstiilit

Master's Thesis

Advisor: Kari Salonen, professor, TUT

Faculty of Built Environment: School of Architecture

Department of Architectural Design: Building Construction

06062007 / 07042010

Abstract

TAMPERE UNIVERSITY OF TECHNOLOGY

Master's Degree Programme In Architecture

KUUSISTO, TERHI KRISTIINA:

Textile in Architecture

Master's Thesis

Pages: 100

Appendixes: 2

26052010

Architectural Design: Building Construction

Advisor: professor Kari Salonen, TUT

Key words: architextiles, fabric, fabric architecture, light weight, tensile, textile architecture, textile

The use of textile in architecture has become increasingly popular in the recent years. Therefore there is a growing demand for texts introducing this exciting topic. The aim of this thesis is to have a look at the possibilities related to textile architecture from the architectural point of view and also, from the point of view of textile design, and to combine these fields into a horizontal study. The aim is to provide an information package suitable for specialists of different, but related fields. Also, we look at the possibilities brought about by the study and picture a concept for the use of textile in architecture. In this thesis, we discuss the main lines of the development of textile architecture in three sections: Textile in Architecture, Textile for Architecture and Textile and Architecture. The study also introduces realized applications of textile architecture and architectural textiles and fabrics.

The section "Textile in Architecture" discusses the roots of textile architecture. We begin by discussing the tents of the early nomad cultures in world history, starting from prehistory and continuing to our days. We have a look at other similar early applications related to the matter as well. We continue by investigating at the development of textile architecture in the western history of architecture of the early industrialization period. After this, we study innovations of the 20th century on the global scale. In particular, we discuss structures belonging to the three main technical categories of textile-based architectural structures: tensile fabric membrane and cable net structures, large-span applications and (especially) air-structures, and finally fabric facades.

The section "Textile for Architecture" is a general study of technical textiles and the most common textile structures for the purposes of architecture. The use of fabrics in architecture brings together the possibilities offered by both textile and construction industries. We also discuss the technicalities related to textile industry, with the focus on the properties of technical textiles designed especially for the use of architecture. We first have a look at composite fabrics, and then discuss the future generation of materials for textile architecture - the intelligent materials. We then provide detailed a study of a selection of fabric manufacture related techniques.

Finally, we conclude the study by a suggested application of textile architecture. The section "Textile and Architecture" brings together the ideas and further suggestions brought about by the study. The result is a concept for a project "Textile market", an ephemeral event for architextiles for the World Design Capital Helsinki 2010.

This thesis was written as part of the Master's Degree Programme in Architecture of Tampere University of Technology. The related work was conducted as an independent project.

Tiivistelmä

TAMPEREEN TEKNILLINEN YLIOPISTO

Arkkitehtuurin koulutusohjelma

KUUSISTO, TERHI KRISTIINA:

Arkkitehtuurin tekstiilit

Diplomityö

Sivuja: 100

Liitteitä: 2

26052010

Rakennussuunnittelu: Rakennusoppi

Tarkastaja: professori Kari Salonen, TTY

Avainsanat: kangas, kevyet rakenteet, tekstiili, tekstiiliarkkitehtuuri, vedetyt rakenteet

Tekstiiliarkkitehtuurin suosio on tämänhetkinen ilmiö. Tarve tätä mielenkiintoista aihetta käsitteleville teksteille on ajankohtainen. Diplomityöni tarkoitus on tarkastella tekstiiliarkkitehtuurin mahdollisuuksia sekä arkkitehtuurin että tekstiilisuunnittelun näkökulmasta ja yhdistää tieto horisontaalisti. Tavoitteena on usean sisältöön liittyvän alan osaamista tukevan tietopakedin kerääminen. Lisäksi työssä yhdistetään karttunut tieto ja luonnostellaan tekstiilimateriaalin hyödyntämismahdollisuuksia arkkitehtuurissa. Diplomityössä kuvataan tekstiiliarkkitehtuurin kehitystä kolmen pääotsikon alla: Tekstiiliarkkitehtuuri, Arkkitehtuurin tekstiilit sekä Tekstiili ja arkkitehtuuri. Aihe on rajattu sisältämään toteutettuja sovelluksia.

Tekstiiliä on käytetty osana arkkitehtuuria ja arkkitehtonisena materiaalina jo muinaiskulttuureissa. "Tekstiiliarkkitehtuuri"-osiossa kuvataan tekstiiliarkkitehtuurin juuria ja kehitystä. Aluksi kuvataan ensimmäisiä tekstiilimateriaalia hyödyntäviä asumuksia, nomadien telttoja, alkaen esihistorialliselta ajalta. Materiaali esiintyy rakentamisen ohella myös muun teknologian kehityksessä. Aiheen käsittelyä jatkavat muutamat säilyneet esimerkit varhaishistorian ja länsimaisen arkkitehtuurihistorian alkuajoilta. Tämän jälkeen tarkastellaan teollisen vallankumouksen vaikutusta rakennusmateriaalien ja -tekniikoiden sekä tekstiilin käytön kehitykseen arkkitehtuurissa. Lopuksi tutustutaan 1900-luvun esimerkkeihin maailmanlaajuisessa perspektiivissä. Arkkitehtoniset ratkaisut on jaettu kolmeen yleiseen kategoriaan: vedettyihin kalvo- ja köysirakenteisiin, pitkien jänneväliden rakenteisiin (erityisesti pneumaattisiin rakenteisiin) sekä kangasjulkisivuihin.

Tekstiiliarkkitehtuuri yhdistää tekstiili- ja rakennusteollisuuden osaamisen. "Arkkitehtuurin tekstiilit" -osiossa käydään yleisesti läpi arkkitehtonisiin tarkoituksiin soveltuvat tekniset tekstiilit. Tämän lisäksi luodaan katsaus tekstiiliteollisuuden kehitykseen. Komposiittitekstiilien lisäksi käydään lyhyesti läpi tulevaisuuden tekstiilimateriaaleja, funktionaalisia tekstiilejä ja älymateriaaleja. Lopuksi tutustutaan tavallisimpiin tekstiilirakenteisiin, kudottuihin, neulottuihin ja nonwoven -rakenteisiin sekä niiden valmistustekniikoihin. Tekstiiliarkkitehtuurissa materiaalivalintaan vaikuttavat olennaiset tekijät käydään läpi yhdessä eurooppalaisilta tekstiilivalmistajilta vastaanotettujen materiaaliesimerkkien esittelyn rinnalla.

Työn päättää "Tekstiili ja arkkitehtuuri" -osio ja selvityksessä opitun tiedon yhdistävä tekstiiliarkkitehtuurikonsepti, "Tekstiilitori". Konsepti on väliaikainen tapahtuma vuoden 2012 maailman designpääkaupunkiin Helsinkiin. Osio yhdistää työn kuluessa nousseet ideat ja etsii tekstiiliarkkitehtuurin uusia mahdollisuuksia.

Tämä diplomityö on tehty Tampereen teknillisen yliopiston arkkitehtuurin koulutusohjelman arkkitehdin tutkinnon opinnäytetyöksi. Työ on kirjoitettu itsenäisenä työnä.

Preface

Gottfried Semper, the German theorist from the 19th century, is widely cited architect in the textile architecture related bibliography. According to him, textile art is a primordial art. It originates from itself and from concepts analogous to structures of nature. All other arts, including architecture, borrow their archetypes from textile art. (Semper 1830–1879)

In the 1990's, architecture found new ways of expression thanks to computer-aided design. It enabled complicated forms to be studied with precision. Architect Greg Lynn innovated the term blob architecture in 1995. Frank Gehry designed the much discussed Guggenheim Museum in Bilbao in 1997. This was the time for new, uncanny forms, blobs and freeform surfaces. Coordinates were skewed. Materials became ethereal. Surfaces veiled the structure like clothes veil a person. Architectural exhibitions offered applications of textile and fabrics, but textile materials were still widely unrecognised in the industry. Textile was still rare in architecture. This was when I became interested in this material, absent from architecture, and applied and got accepted to the Department of Textile Art and Design in Helsinki University of Art and Design. My aim was to combine the two media and my dream was to see more textile in exterior architecture.

My study for the Master of Science in Architecture was a brilliant possibility to thrive for my ideal. To discuss my idea, I contacted Kari Salonen, professor of Building Construction in the Department of Architectural Design of Tampere University of Technology. He was extremely supportive of my idea. Also, I learnt that he had participated in the design of the summer theatre fabric roof of Pyynikki, in Tampere. This made him suitable for advising my work. I requested him to be my advisor and he agreed. During the course of my work, our discussions encouraged me further. He gave me many new and fertile viewpoints to think about the matter and suggested interesting contacts to check. The study was realised as an independent piece of work.

My understanding of the subject became increasingly concrete during my work. At first my ideas were rather general and my list of topics only a draft. The material available conducted my work and challenged my early thoughts. The study became quite different from what I expected as I became more familiar with the material. In the beginning of my work in 2007, not much information was available on the subject. I depended on a few handbooks with somewhat obsolete information, but still offering a solid basis for the subject. I studied the history of architecture and the history of textiles. I read about material technology and design as well as textile manufacturing sources. A lot of the information was on the internet and in journals and magazines. I found theses tangential to my subject. Some of the few fabric manufacturers in Europe provided me with practical information and sample materials. An important source of information was ebrary with its scientific articles from all over the world. Without it, much of the information in this thesis would be absent. Discussions with colleagues and other specialists helped me to shape my work. I delved into the perspectives of the commissioner, the designer, the engineer, the fabric manufacturer, the different constructors and the end-user. When finishing my work in 2010, I observed that the amount of material written about textile architecture – journal articles, websites and books – had multiplied. This was a delightful observation.

This study, "Textile in Architecture", is divided into three main sections. The first one deals with the roots of "Textile in Architecture". The second one concentrates on "Textile for Architecture", i.e., fabric materials (flexible engineered materials) for architecture. The third and the last part concludes the discussed material by introducing an application of "Textile and Architecture" – a concept "Textile Market" for the World Design Capital Helsinki 2010.

The work could not have been completed without the help of others. I want to thank my advisor Kari Salonen for the encouragement and the very open attitude towards architecture and my subject. The support and the discussions with my family, friends and colleagues at work was extremely important to me. Especially, I want to thank Antti Kuusisto, Paula Kuusisto, Jaana Woll, Markku Pietilä and Mia Puranen for their support. Thank you all who helped me; family, friends and colleagues. Thank you for dressing up my architecture!

Contents

Introduction Johdanto

I ARCHITECTURE – FROM VERNACULAR TO HIGH-TECH Textile in Architecture

I Textile in Architecture of Unknown Builders	21
1.1 Tents	21
1.11 The Black Tent	22
1.12 The Yurt	24
1.13 The Tipi	25
2 From Tents to the 20th Century	27
2.1 Early Examples	27
2.11 Velaria over the Colosseum	27
2.12 Royal Court Tents	28
2.2 Industrialism and New Possibilities	29
2.21 The Circus Tent	30
3 The 20th Century Maturation	33
3.1 Fabric Membrane and Cablenet Structures	34
3.11 Music Pavilion, Kassel	35
3.12 Tanzbrunnen, Cologne	35
3.13 German Pavilion for Expo '67, Montreal	36
3.3 Large Span Gridshell and Air-structures	39
3.31 Mannheim Multihalle Gridshell Dome	42
3.32 American Pavilion Air-supported Structure, Osaka	43
3.33 Fuji Company Pavilion Air-infilled Structure, Osaka	44
3.4 Fabric Facades	45
3.41 British Pavilion for Expo 92', Seville	45
4 Textile and Fabric Structures	46
4.1 The Design of Textile and Fabric Structures	46
5 A Case Study	48
5.1 Contemporary Fabric Architecture	49
5.11 Haj Terminal of King Abdul Aziz International Airport, Jeddah	49
5.12 Schlumberger Cambridge Research Centre, Cambridge	51
5.13 Curtain Wall House, Tokyo	53
5.14 Millenium Dome (O ₂), London	54
5.15 Eden Project, St. Austell	56
5.16 Spiky Pod, London	57

II TEXTILE – ARCHITEXTILE BASICS Textile for Architecture

6 Architextiles	61
6.1 Textile, Fabric, Fibre	62

6.2 Technical Textiles	63
6.21 Coated and Laminated Textile Fabric Composites	64
6.3 Intelligent (Smart) Textiles and Materials	64
6.31 Chromic materials	65
6.32 Conductive Materials	66
6.33 Electricity Generating Materials	66
6.34 Phase Change Materials (PCMs)	67
6.35 Shape Memory Materials (SMMs)	67
7 Fabric Manufacturing	68
7.1 Fibres	68
7.2 Textile and Fabric Manufacture	69
7.21 Woven Structures and Weaving	69
7.22 Knitted Structures and Knitting	70
7.23 Nonwoven Structures and Nonwovens	71
7.3 Fabric Finishing, Coating and Lamination	73
7.4 Coloration of Fabrics	74
8 Choosing the Fabric	75
8.1 The Essential Fabric Properties	75
8.11 Tensile Strength and Tear Strength	75
8.12 Resistance to Buckling and Mechanical Wear	75
8.13 Weight	76
8.14 Durability	76
8.15 Weather and Temperature	76
8.16 Resistance to Chemicals	76
8.17 Properties Concerning Light	76
8.18 Colour	77
8.19 Acoustic and Thermal Properties	77
8.20 Properties Related to Fire	77
8.21 Cleaning and Maintenance Properties	77
8.2 Cost-Related Issues	78
8.3 Ecological Issues	78
8.4 Fabric Quality and Assembly	78
8.5 Common Fabrics for Architecture	79
8.51 PVC Coated Polyester	79
8.52 PTFE Coated Fibreglass	79
8.6 A Sample List	81

III CONCEPT - TEXTILE MARKET Textile and Architecture

9 Conclusions	85
10 Concept: Textile Market	87
Bibliography	95
Illustration Credits	98
Appendices	99

Introduction

The driving force behind this work came from the absence of textile material in Finnish architecture. The goal of this thesis is to bring together the information on architecture and textile and put together a package of information to support the use of architextiles in architecture. The study concentrates on the matter on a general level. The information is meant to serve several fields of specialists related to this matter. A concept for a textile architecture event concludes the learnt material.

The Background

Leafing through the architecture and design magazines at the beginning of my architecture studies in Tampere University of Technology, textile and fashion started to appear side by side with architecture. Shapes were borrowed from the construction and vehicle industries, from structures, cars, boats, even from aeroplanes. Metal and wood were used as construction materials for clothing. One of the pioneering fashion designers was Hussein Chalayan with his veneer skirt and the airplane dress. Also textile material was used innovatively and combined with techniques familiar to scale modelling, using tapes, small nails, staples and wire. Handcraft became a central source of inspiration. The era seemed to start the horizontal approach to architecture and design, but not for the first time in the course of history. Different fields approached other fields to find new insights and to expand their vocabulary.

Textile architecture employs a wide spectrum of flexible engineered materials. Also called architextiles, these materials are designed to serve their specific purpose. Since the word "textile" has such strong connotations in the minds of people, it is widely accepted in the field of architecture to describe the phenomenon of architecture employing flexible engineered materials in its structures. From the point of view of material science, the more accurate term concerning the scope of materials in textile architecture would be "fabric". A new hybrid term, released in an issue of Architectural Design -journal in 2006, is "architextiles". This term is also worth mentioning, as it describes these materials in a suitably fuzzy way.

Textile is the fifth material of architecture among timber, stone, metal and glass. Several articles in professional journals and magazines of the past ten years describe projects benefiting from the advantages of using textile side by side with traditional construction materials. In some solutions, textile is even replacing them. The internet is full of information, manufacturers, designers, engineers, constructors, even new fields of education. When a few years ago the source materials discussing the topic were scarce. The situation has changed drastically. This is a fine point in history to familiarize oneself with the concepts related to textile in architecture.



I Hussein Chalayan's veneer skirt. The dress can be turned into a table with four legs. It is from Hussein Chalayan's autumn/winter collection 2000, see the top figure on the left. (www.husseinchalayan.com)

II Hussein Chalayan's airplane dress from the spring/summer 2000 collection uses forms and material normally associated with aviation, see the middle figure on the left. (www.metmuseum.org)

III "BMW GINA light visionary model concept car", launched in 2008, has a textile cover over its frame, see the bottom figure on the left. (www.tekniikkatalous.fi)

Significant museums in the world have curated exhibitions on textiles and architecture. In 2005, the American National Design Museum Cooper-Hewitt in New York, pioneered the first grand exposition on technical textiles called "Extreme Textiles". In the following year 2006, the architectural journal AD, Architectural Design by John Wiley & Sons, published an edition on textile architecture, called "Architextiles". In 2006–2007 the exhibition "Skin + bones: Parallel practices in fashion and architecture" in the Museum of Contemporary Art in Los Angeles paralleled fashion with architecture. (AD 2006; Cooper-Hewitt 2005; MOCA 2006–2007)

The dynamism of our times, "the liquid modernity" like it is called by sociologist Zygmunt Bauman, exiges flexibility and lightness instead of the monumental, sedentary architecture of the earlier times. Computer-aided design and -manufacture, together with the new possibilities of material technology, increase architecture's possibilities to develop towards its fresh, new future. The new technologies have generated new forms of architecture. On the other hand the developments in textile industry and other related industries have opened new possibilities for the architectural expression. In Architectural Design, the editor of the publication Marc Garcia, discusses textilisation of architecture and architecturalisation of textiles. He lists qualities associated with architextiles such as "fluid, adaptable, interactive, variable, functional and dynamic" (Garcia 2006a, 10).

The Study

The study is divided into three main sections. The first one deals with the roots of "Textile in Architecture". The second concentrates on "Textile for Architecture", i.e., fabric materials (flexible engineered materials) for architecture. The third and the last part concludes the discussed material in the form of an application of "Textile and Architecture": a concept "Textile Market".

The first section, "Textile in Architecture", discusses the roots of textile architecture. Along with the examples of architectural projects and textile materials, a story of the development of structures suitable for textile architecture is developed. We discuss a number of documented and realized projects, where textile is an integral part of architecture.

"Textile in Architecture" is a timeline from prehistory and the vernacular architecture of the nomads through Western history of architecture and textiles, with examples from antiquity, renaissance and industrialism, to the 20th century maturation of textile structures and materials. A case study of six advanced, superlative cases of textile architecture end the first part of the study, the part of the study focused primarily on architecture.

The second section, "Textile for Architecture", describes architextiles. It discusses materials, their structures and manufacturing methods. Intelligent (smart) textiles and materials are introduced. The section ends with a selection of some of the most common architectural fabrics and their properties in order to gain a tactile understanding of architextiles. The discussion concentrates on broad fabrics, focusing mainly on textile fabric composites. However, textile and fabric materials overlap with other flexible engineered materials, and some such materials are included in the discussion. This includes an example from plastic industry and also materials benefiting from textile technology, although not considered textile materials themselves. Metal fabrics are an example. At this point, the fuzzy character of architextiles becomes clear. Narrow fabrics, such as ropes, are not discussed in this study.

"Textile for Architecture" is a general study of technical textiles and the most common textile structures for the purposes of architecture. The use of architextiles brings together the possibilities offered by both textile and construction industries. The technicalities related to textile industry are discussed with the focus on the properties of technical textiles designed especially for the use of architecture. Technical textiles, composite fabrics, intelligent (smart) materials, the most common textile structures and their manufacturing techniques, and finally, their properties and sample materials are introduced. Along with the materials, textile structures are studied as they have their own possibilities for the future architectural applications. The structures combined with other materials than textiles, is an intriguing possibility.

The lack of textile materials in Finnish architecture was one of the catalysts for this study. The last section of the study, "Textile and Architecture", combines the ideas and concepts originating from the information discussed in the study. It gathers together the learnt material in a discussion of a concept for ephemeral textile architecture. The concept explores the multiplicity of architextiles and sketches a picture of future possibilities for the use of the material in a moderate scale. Through the designed concept, my wish is to introduce architextiles to colleagues and students in an easy, understandable way. This concept is called "Textile Market".

The Motivation, the Questions and Goals

The driving force behind this work came from the absence of textile materials in Finnish architecture. It became clear almost immediately that it is necessary to discuss the field from the global perspective. Textile architecture is architecture of the world, it is global architecture.

My goal is to bring together the information on architecture and textile and form a compact information package of the two fields. My aim was to study the backgrounds of both architecture and textile and combine them together in the study. As student in architecture, the possibilities of this material intrigued me. As student in textile art and design, I wanted to look at textile designer's possibilities with textile materials in architecture. The most challenging part of the project was to bring the scattered information together. This seemed to be one of the first attempts to combine architecture and textile in a broad study and to map the relationships of the developments of these two separate fields in the history.

I am interested in continuing my studies of textile architecture. My wish related to this thesis is to develop my own expertise, something that could be beneficiary to me in my future career. The significance of this study is to form a basis for a further study for a multidisciplinary group of people. A general and horizontal approach is the aim.

The questions, or more accurately, the tasks related to this study, are to form a perspective on textile architecture and its development, to investigate its materials and structures as well as the purposes for which textile is often used for in architecture. All this combined together should provide understanding of the matter in one package. With the studied material and information, it is possible to bring together ideas and possibilities for textile architecture in Finland and to find ways to introduce this material to the common practice. At this point, it is clear that the study investigates the matter from a general perspective.

The Sources

The study was conducted investigating significant cases of textile architecture and textile materials in order to build a perspective on the matter. The example cases were chosen as they are the significant examples of textile architecture or structures related to it. The study is not an exhaustive description of the issue, but a general approach to textile architecture. The study was process oriented. As the subject is horizontal in nature, I was challenged to familiarize myself with fields unknown to me to some extent. The contents of the study were constantly adjusted. The goals became clearer towards the end of the work. It led to the decision of designing a reference concept for textile architecture using the cumulated information. The solution was open until the very end.

The main source of information was written information. Realized cases of architecture were found in books on architecture and textile related information in a few introductory handbooks on the subject. When I began the study, the information was scarce. During the course of my work, multiple

publications were published, and it made my work more fertile.

The two main fields of this study, architecture and textile, are mostly discussed in separate sources. My challenge was to find relationships between the two. Information about textile architecture is mostly in books on the history of buildings and structures. Textile related issues were discussed in books on textile techniques, material science, textile design and also websites. Combining these two different fields of information was challenging.

The information in the handbooks and history books was sometimes dated compared to the information in the internet. This is why a lot of the information in the thesis originates from manufacturers' web pages, from the documents of textile industry's various branch organizations and architecture office's websites. I contacted some European manufacturers' representatives by email for information and samples. Some responded and the material is included in this study. Ebrary, the digital library of Tampere Technical University was an endless source of information with access to journal articles, books, magazines and standards, to name a few.

My advisor Kari Salonen is one of the specialists who have designed the summer theatre fabric roof in Pyynikki, Tampere in Finland. I gained a lot from the discussions with him. I also observed my environment to have a picture of the reality of textile architecture in Finland. An empirical part of my study was realized by walking on the streets of Helsinki and observing the textiles and plastics in the city and by imagining further possibilities for the use of textiles. Also, I discussed with colleagues in search of inspiration.

I Hussein Chalayanin vanerihame. Hameen voi muuttaa nelijalkaiseksi pöydäksi. Se on kokoelmasta syys/talvi 2000, ylin kuva oikealla. (www.husseinchalyan.com)

II Hussein Chalayanin lentokone-mekko kevät/kesä 2000 kokoelmasta. Mekko toistaa lentokoneen tekniikkaa nousevine siipineen, kuva keskellä oikealla. (www.metmuseum.org)

III "BMW GINA light visionary model concept car" vuodelta 2008. Prototyyppi on puettu kangaskuoreen, joka joustaa auton aukotuksia avattaessa, kuva alhaalla oikealla. (www.tekniikkatalous.fi)

Johdanto

Merkittävä tekijä diplomityöni aiheenvalinnalle oli tekstiilimateriaalin harvinaisuus suomalaisessa arkkitehtuurissa. Työn tarkoituksena on ollut yhdistää tieto arkkitehtuurista sekä tekstiilistä ja koota ne yhdeksi kokonaisuudeksi. Aihetta käsitellään yleisellä tasolla. Yhteenvetona diplomityö kokooa kerätyn tiedon "Tekstiilitori"-konseptiksi.

Taustaa



Opiskelujeni alkuvaiheessa, silloisessa Tampereen teknillisessä korkeakoulussa, selasin arkkitehtuuri- ja muotoilujulkaisuja ja huomasin muodin sekä tekstiilitaiteen esiintyvän artikkeleissa usein arkkitehtuurin rinnalla. Muoti lainasi muotoja raskaasta teollisuudesta, rakennuksista, ajoneuvoteollisuuden tuotteista; rakenteista, autoista, jopa lentokoneista. Metallia ja puu päätyivät vaatetusmateriaaleiksi. Eräs aikakauden edelläkävijöistä oli vaate suunnittelija Hussein Chalayan vanerihameellaan ja lentokonemekollaan. Myös tekstiilimateriaalia käsiteltiin tuoreella tavalla. Se yhdistettiin tekniikkoihin, jotka olivat tuttuja arkkitehtuurin pienoismallirakentamisesta. Teippi, pienet naulat, nastat ja niitit sekä metallivaijeri olivat osa muodin ja tekstiilin ilmaisua. Materiaaleja revittiin, rei'itettiin, solmittiin – käsiteltiin rohkein, mullistavin tavoin. Pian käsityö ilmestyi julkaisuihin. Siitä tuli teollisten alojen mielenkiinnon kohde. Aikakausi näytti aloittavan horisontaalin ajanjakson, jossa suunnittelun eri alueet lähestyivät toisiaan ja lainailivat toisiltaan. Tämä ei kuitenkaan ollut ensimmäinen kerta historiassa. Eri alat lähestyivät ja lomittuivat löytääkseen uutta inspiraatiota ja uusia ilmaisutapoja.



Tekniset tekstiilit ja erikoismateriaalit ovat tekstiiliarkkitehtuurin materiaaleja. Rakennustekstiilit sisältävät lukuisia materiaaleja arkkitehtonisiin tarkoituksiin. Englanninkielinen termi "architextile", "arkkitekstiiili", tarkoittaa materiaaleja, jotka on suunniteltu täyttämään käyttötarkoituksestaan syntyvät ominaisuudet. Sana "tekstiili" on merkityssisällöltään vahva ja tunnistettava. Vaikka materiaalitekniikan kannalta tekstiiliarkkitehtuurin materiaaleille löytyy vaihtoehtoisia ilmaisuja, kuten kangas, kalvo, muovi tai folio, on sana "tekstiili" yleisesti käytetty ja hyväksytty termi kuvaamaan tekstiiliarkkitehtuurin monia materiaaleja. Se pitää sisällään useita eri valmistustekniikoin ja -materiaalein toteutettuja tuotteita.



Tekstiili on arkkitehtuurin viides materiaali puun, kiven, metallin ja lasin rinnalla. Lukuisat arkkitehtuurin ammattijulkaisujen ja aikakauslehtien artikkelit sisältävät kuvauksia kohteista, joissa tekstiili on osa arkkitehtonista ilmettä. Osassa se jopa korvaa perinteisiä ratkaisuja ja materiaalivalintoja. Internet pursuaa tietoa, valmistajia, suunnittelua, insinööriosaamista, rakennuttajia, jopa uusia opintomahdollisuuksia. Kun muutama vuosi sitten tietoa oli haastava löytää, on tarjonta nyt ylitsevuotavaa. Aika on kypsä arkkitehtuurin tekstiileihin tutustumiselle.

Merkittävät toimijat maailmassa järjestävät näyttelyitä arkkitehtuurin ja tekstiilien ympärille. Vuonna 2005 New Yorkin Cooper-Hewitt museo, maan kansallinen muotoilumuseo, järjesti ensimmäisen suurimittakaavaisen näyttelyn teknisistä tekstiileistä, nimeltään "Extreme Textiles", vapaasti käännettynä "äärimmäiset tekstiilit". Vuonna 2006 John Wiley & Sons -kustantamon ammattijulkaisu Architectural Design, AD, julkaisi kokonaisen numeron "arkkiteksteileistä", "Architextiles". Vuosina 2006-2007 Los Angelesin nykyaikaisen museon MOCA järjesti näyttelyn nimeltä "Skin + bones: Parallel practices in fashion and architecture", "Iho ja luusto: muodin ja arkkitehtuurin rinnakkaisuus". (Cooper-Hewitt 2005; AD 2006; MOCA 2006–2007).

Nykymodernismin dynaamisuus, notkea modernismi, kuten sosiologi Zygmund Bauman aikaamme kuvaa, edellyttää joustavuutta ja keveyttä perinteisen monumentaalien ja pysyvän arkkitehtuurin sijaan. Tietokoneavusteinen suunnittelu ja -valmistus yhdessä materiaalitekniikan kehityksen kanssa avaavat uusia mahdollisuuksia arkkitehtuurin uudelle, tuoreelle ilmaisulle. Uusi teknologia on myös jokapäiväistänyt uudet muodot arkkitehtuurissa. Uudet tarpeet ovat edellyttäneet rakennusmateriaalien kehitystä. Toisaalta materiaalitekniikan kehitys on mahdollistanut uuden arkkitehtonisen ilmaisun toteuttamista. Architectural Design -lehden "Architextiles"-julkaisussa lehden toimittaja kuvaa arkkitekstiilien etuja sanoin "nestemäinen, sopeutuva, vuorovaikutteinen, muuttuva, toiminnallinen ja dynaaminen" (Garcia 2006a, 10).

Arkkitehtuurin tekstiilit

Arkkitehtuurin tekstiilit -diplomityö jakautuu kolmeen sisällöltään erilliseen osaan. "Tekstiiliarkkitehtuuri", käsittelee tekstiiliarkkitehtuurin juuria. "Arkkitehtuurin tekstiilit" käy läpi arkkitehtuurin tekstiilejä. Kolmas ja viimeinen osa on sovellus ja yhteenveto opitusta tiedosta, "Tekstiilitori"-konsepti.

Työn ensimmäinen osa, "Tekstiiliarkkitehtuuri", kuvaa tekstiiliarkkitehtuurin ilmiön juuria esimerkkien kautta. Esieltyjen arkkitehtuurikohteiden ja tekstiilimateriaalin käytön rinnalla kulkee tarina rakenteiden kehityksestä. Valitut tarkastelukohteet on valittu esimerkeistä, joissa tekstiili on merkittävä osa arkkitehtonista ilmettä. Projektit ovat toteutettuja ja dokumentoituja kohteita, joissa yhtä poikkeusta lukuunottamatta tekstiili on ulkoarkkitehtuurin osa.

"Tekstiiliarkkitehtuuri" on kuvaus ajanjaksosta tekstiiliarkkitehtuurin ensimmäisistä sovelluksista kohti kypsän tekstiiliarkkitehtuurin aikakautta ja high-tech sovelluksia. Esihistoria ja nomadikulttuurien kansanrakentaminen tai telta-arkkitehtuuri, on ensimmäisiä esimerkkejä valmistetusta tekstiilimateriaalista ja rakennetuista asumuksista. Antiikin ajalta on säilynyt muutama esimerkki. Ensimmäiset sovellukset on tehty suojiksi sään vaikutuksilta tai avuksi sodankäyntiin. Eurooppalaiset hovit renessanssin ajasta barokkiin nauttivat tekstiiliarkkitehtuurista puutarhapaviljongeissaan ja ke-

hittävät huveja oman valtansa korostamiseksi. Tässä apuna oli usein tekstiiliä hyödyntävät rakennukset ja rakennelmat. Teollistumisen aikakauteen tekstiili liittyi vahvasti. Se oli yksi kehityksen liikkeellepanijoista. Kaupungit ja uudet rakennukset, tehtaot ja hallit rakennettiin usein juuri tekstiiliteollisuuden näyttämöksi. Samalla kehittyivät rakennusmateriaalit ja tekniikat. Tekstiili osana arkkitehtuuria saa siemenensä tältä aikakaudelta.

1900-luvun maailmansodat kiihdyttivät kehitystä. Sota ja sen tarpeet kevyille, liikuteltaville ja pieneen tilaan pakkautuville materiaaleille nostivat tekstiilin eturintamaan. Tekstiilisovellukset sekä rakentamisessa että arkkitehtuurissa lisääntyivät merkittävästi sotien seurauksena. Aluksi ne olivat kokeilevia näyttelyrakennuksia maailman arkkitehtuurinäyttelyissä. Vähitellen kehitettiin myös kaupallisia sovelluksia. Pysyvä, jopa monumentaalinen arkkitehtuuri otti tekstiilimateriaalin sanastoonsa vuosiasan loppuvuosikymmeninä. Julkisivuun tekstiili löysi tiensä varsinaisesti vasta 1990-luvulla. Tässä vaiheessa tekstiili oli jo hyväksytty materiaalina muiden rakennusmateriaalien rinnalla.

“Tekstiiliarkkitehtuuri” on yksi kuvaus tekstiilin käytöstä ja käytön kehityksestä arkkitehtuurissa. Historiallisen tarkastelun lopuksi on valittu nykyarkkitehtuurin kuusi kohdetta esittelemään kehittynyttä tekstiiliarkkitehtuuria. Nämä esimerkit päättävät tarinan tekstiiliarkkitehtuurin kehityksestä 2000-luvulle.

Diplomityön toinen osa, “Arkkitehtuurin tekstiilit”, käsittelee tekstiiliarkkitehtuurin materiaaleja. Materiaalien lisäksi käydään niiden rakenteita ja valmistusmenetelmiä läpi yleisellä tasolla. Lisäksi tutustutaan funktionaalisiin älymateriaaleihin ja niiden ominaisuuksiin. Tekstiilintuntu on yksi tekstiilimateriaalin tärkeistä ominaisuuksista. Osan päätteeksi esitelläänkin tavallisimmat arkkitehtuurin tekstiilit ja niiden ominaisuudet sekä näyte-esimerkit. Valitut kankaat ovat pääosin päällystettyjä tai laminoituja komposiittitekstiilejä.

“Arkkitehtuurin tekstiilit” on yleinen kuvaus teknisistä teksteleistä ja tavallisimmista tekstiilirakenteista arkkitehtuurin tarpeisiin. Arkkitehtuurin tekstiileissä yhdistyy sekä tekstiiliteollisuuden että rakennusteollisuuden tarpeet ja mahdollisuudet. Sisältöön kuuluvat tekniset tekstiilit ja rakennustekstiilit, komposiittitekstiilit ja älymateriaalit. Tavallisimmat tekstiilirakenteet, kudotut -, neulotut - ja nonwoven-tekstiilit ja niiden valmistustekniikat käydään myös läpi. Niistä jokainen tarjoaa oman, erityisen mahdollisuutensa arkkitehtuurin sovellusten toteuttamiseksi. Lisäksi tekstiilirakenteiden käyttö muiden kuin tekstiilimateriaalien kanssa, on kiinnostava mahdollisuus.

Arkkitehtuurin tekstiilit risteävät tekstiili-, muovi- ja paperiteknologian tuotteiden kanssa. Poikkeuksia joukossa ovat muoviesimerkit sekä tekstiilitekniikkaa hyödyntävät materiaalit, joita ei kuitenkaan lasketa tekstiili- tai

muovimateriaaleiksi. Tällaisia sovelluksia ovat esimerkiksi metallista kudotut kankaat. Tekstiiliarkkitehtuurin materiaalien sumea rajausta korostuu juuri näiden esimerkkien kautta. Kapeita ja nauhamaisia tekstiilejä kuten köysiä ei käsitellä tässä selvityksessä.

Tekstiili on edelleen harvinaisuus suomalaisessa ulkoarkkitehtuurissa. Seikka oli oleellinen katalyytti diplomityöni aiheenvalinnassa. Selvityksen viimeinen osio, "Tekstiili ja arkkitehtuuri", pyrkii yhdistämään selvitystyössä esille tulleen tiedon. Se on konsepti hetkellisestä tekstiiliarkkitehtuurista. Tämä idea, "Tekstiilitori", esittelee arkkitehtuurin tekstiilit helposti lähestyttävällä tavalla. Se tuo tekstiilin torille, mutta ei enää myytäväksi tuotteeksi vaan osaksi torin rakennetta. Arkkitehtuurin tekstiilien monipuolisuus yhdistyy toiminnalliseksi rakenteeksi Suomeen sopivassa mittakaavassa. Väliaikainen tekstiiliarkkitehtuuritapahtuma ottaa itselleen parhaat osoitteet ja viipyy paikalla hetken. Tekstiiliarkkitehtuurin aika on nyt!

Lähtökohdat ja työn tarkoitus

Tekstiilimateriaalin arkkitehtoninen käyttö suomalaisessa arkkitehtuurissa on haaste. Diplomityöni edetessä oli selvää, että aihetta tuli käsitellä kuitenkin laajassa mittakaavassa, osana kansainvälistä arkkitehtuuria. Tekstiiliarkkitehtuuri on maailman arkkitehtuuria, kansainvälinen ilmiö.

Diplomityöni tarkoitus on yhdistää arkkitehtuuri ja tekstiilimateriaali ja rakentaa niistä yhteinen esitys. Pyrkimyksenä on tutustua arkkitehtuurin ja tekstiilin yhteisiin taustoihin ja yhdistää kahden eri alan tieto yhdeksi. Arkkitehtiopiskelijana minua kiinnostaa tekstiilin mahdollisuudet materiaalina ja osana arkkitehtonista ilmaisua. Tekstiilitaiteen opiskelijana haluan tutustua tekstiilin arkkitehtuurille tuomiin mahdollisuuksiin myös tekstiilin lähtökohdista. Tarkoituksena on rakentaa pohja tekstiiliarkkitehtuurin taustan, sen nykyisen käytännön ja tulevaisuuden kehityksen ymmärrykselle. Sisältö kerääkin yhteen usean eri alan ja toimijan tietoja. Oleellista työssä oli kerätä useaan eri lähteeseen jakautunut tieto; etsiä arkkitehtuurin ja tekstiilin mahdollisia yhteyksiä ja suhteita. Haasteena oli tiedon yhdistäminen ja sen suodatus. Työn kuluessa huomasin, että diplomityöni on ensimmäisiä yrityksiä, joissa nämä kaksi eri alaa taustoineen pyritään liittämään näinkin kiinteästi toisiinsa. Erillisiä esityksiä aiheista on runsaasti.

Mahdollisuus jatkaa opintoja tekstiilin ja arkkitehtuurin parissa kiinnostaa. Diplomityöni pyrkimyksenä on muodostaa osaamispohja, jota voisin hyödyntää tulevaisuudessa. Diplomityön merkitys pyrkii olemaan sen monialaisuudessa. Tarkoituksena on kerätä tietopaketti usean alan asiantuntijan osaamista ajatellen. Tavoitteena on yleinen ja horisontaali lähestyminen. Kysymykset tai oikeammin tehtävä, johon diplomityöni pyrkii vastaamaan on yhden näkökulman muodostaminen tekstiiliarkkitehtuurista: näkökulman, joka ottaa huomioon arkkitehtuurin, tekstiilin, niiden yhteisen kehityksen, käytetyt materiaalit ja rakenteet ja edelleen tarkoitukset, joissa nämä

kaksi ilmiötä kohtaavat. Pyrin yhdistämään aiheet yhdeksi. Tämän näkökulman avulla on entistä helpompi ideoida uusia mahdollisuuksia tekstiilimateriaalille arkkitehtuurissa. Lisäksi materiaalin tutustuttaminen suomalaiseen suunnittelukäytäntöön on tarpeen.

Tiedonkeruu

Tämä diplomityö on näkökulma tekstiiliarkkitehtuuriin. Selvitys on esitetty esimerkkikohteiden avulla; se on "case study". Malliesimerkit on valittu niiden merkittävyyden vuoksi: arvostetun arkkitehtuurin, uudenlaisen tai kehittyneen rakenneperiaatteen tai erityisen tekstiilimateriaalin kautta. Diplomityö on lähestymiseltään yleinen ja horisontaali.

Kun aloitin diplomityöni tekemisen, oli tietolähteitä haastava löytää. Työn edetessä uusia julkaisuja alkoi ilmestyä valtavalla vauhdilla, mikä edesauttoi selvitystyötä merkittävästi. Koska aihe oli monialaista tietoa sisältävä, tustuin alohin, joita en aina ennestään tuntenut. Työ oli prosessorientoitunutta. Työn sisältö tarkentui jatkuvasti työn edetessä. Työn loppuvaiheessa kokonaiskuva selkiintyi ja ymmärsin diplomityön sisällön luomat mahdollisuudet. Ratkaisu oli avoin lähes loppuun asti. Työ johti tekstiiliarkkitehtuurikonseptiin johtopäätökseksi työn sisällölle.

Diplomityön lähteet ovat tekstimuotoisia. Diplomityön kahden pääaihealueen sisällöt, arkkitehtuuri ja tekstiili, löytyvät eri lähteistä. Arkkitehtuuriesimerkit löytyvät alan kirjallisuudesta. Tekstiilitietous karttuu erityisesti merkittävien käsikirjojen avulla. Arkkitehtuuriesimerkit tulee usein poimia muiden arkkitehtuurikohteiden joukosta. Tekstiilisällöt löytyvät insinöörikirjallisuudesta, tekniikoiden, materiaaliopin ja suunnittelun lähteistä. Uusin tieto on verkkosivuilla, ammattijulkaisuissa ja aikakauslehdissä. Käsikirjojen ja historiankirjojen tieto on usein vanhaa, mutta ei kuitenkaan vanhentunutta. Tuorein informaation on etsittävä internetistä. Materiaalivalmistajat, erilaiset organisaatiot ja aiheeseen liittyvät rakennuttajatahot ja arkkitehdit kertovat asiasta sivustoillaan. "e-kirjasto" Tampereen teknillisellä yliopistolla on verraton tuki tiedon kartoittamiseen. Sen artikkelit, kirjat, lehdet ja standardit olivat oleellisia tämän diplomityön sisällön kehitykselle. Lisäksi otin yhteyttä muutamaa eurooppalaiseen materiaalivalmistajaan ja sain heiltä näytemateriaaleja työni tueksi.

Luetun tiedon lisäksi keskustelin ohjaajani rakennusopin professori Kari Salosen kanssa. Hän osoittautui myös aiheen asiantuntijaksi: Kari Salonen on yksi Tampereen Pynnikin kesäteatterin tekstiilikaton suunnittelijoista. Asia oli iloinen yllätys pyydettyäni häntä ohjaamaan työtäni. Myös perheen, ystävien ja työkalavereiden tuki sekä keskustelut heidän kanssaan edistivät työn kulkua. Kävelin Tampereen ja Helsingin katuja ja etsin tekstiiliä kaupungin julkisesta tilasta. Diplomityön sisältöä hyödyntävä sovellusosuus on yhdistelmä tätä empiiristä tutkimusta, vapaata ideointia ja selvitystyössä esiintullutta sisältöä. Tekstiiliarkkitehtuurin lähteet ovat moninaiset.

I ARCHITECTURE

FROM VERNACULAR TO HIGH-TECH

Textile in Architecture

1 Textile in Architecture of Unknown Builders

1.1 Tents

Tents are a prime example of vernacular architecture. Built by unknown builders, they form part of the roots of our traditional architecture. Tents are not the first type of dwelling of the humankind. They are, however, the first type of dwelling using textile as a cover. In some tents, textile functions even as part of the load bearing structure. The valued qualities of tents are very much the same as the sought after in contemporary architecture; lightness, flexibility, contemporaneity, and even portability. (Faegre 1979, 1–25)

Tents are architecture of liquid life. They are the dwellings of the semi-nomad and nomad cultures of the world. Domestication of sheep and goats was the beginning of nomadism. Later, the herd animals such as camels, yaks, reindeers and horses enabled an even greater degree of mobility. The nomad lifestyle required a light structure easy to carry along and to mount. Therefore sedentary huts developed into portable tents. The reason for the mobile lifestyle was survival; water and food. (Faegre 1979, 1–25)

The tent is the shelter of the nomads. It is used in the desert, the steppes, the plains and the tundra and the taiga. The first nomad cultures came from the Middle East and Central Asia, and later, from the circumpolar zones; Siberia, Lapland and North America. Depending on the area, cultural tendencies vary; sometimes the whole tent - sometimes only the covering material - is transported along. (Faegre 1979)

The life span of the textile coverings of tents is short. They are replaced once worn out. The materials of the tent coverings are skin, bark, woven mats, woollen cloths and later, woven canvas. In the nomad societies living in tents, women are the principal architects. Women are responsible for the making of the covering material, whereas men provide the wooden parts. The frame is, in most cases, free standing and carries the weight of the non-structural cover. Of course there are always exceptions, like the black tent of the Bedouins. This tent has a tensile structure, where the textile covering is an essential part of the load bearing structure. (Faegre 1979, 1–25)

Textile and textile-like materials play a substantial role in the architecture of tents. The three examples described here are the starting point of our discourse on textile in architecture.

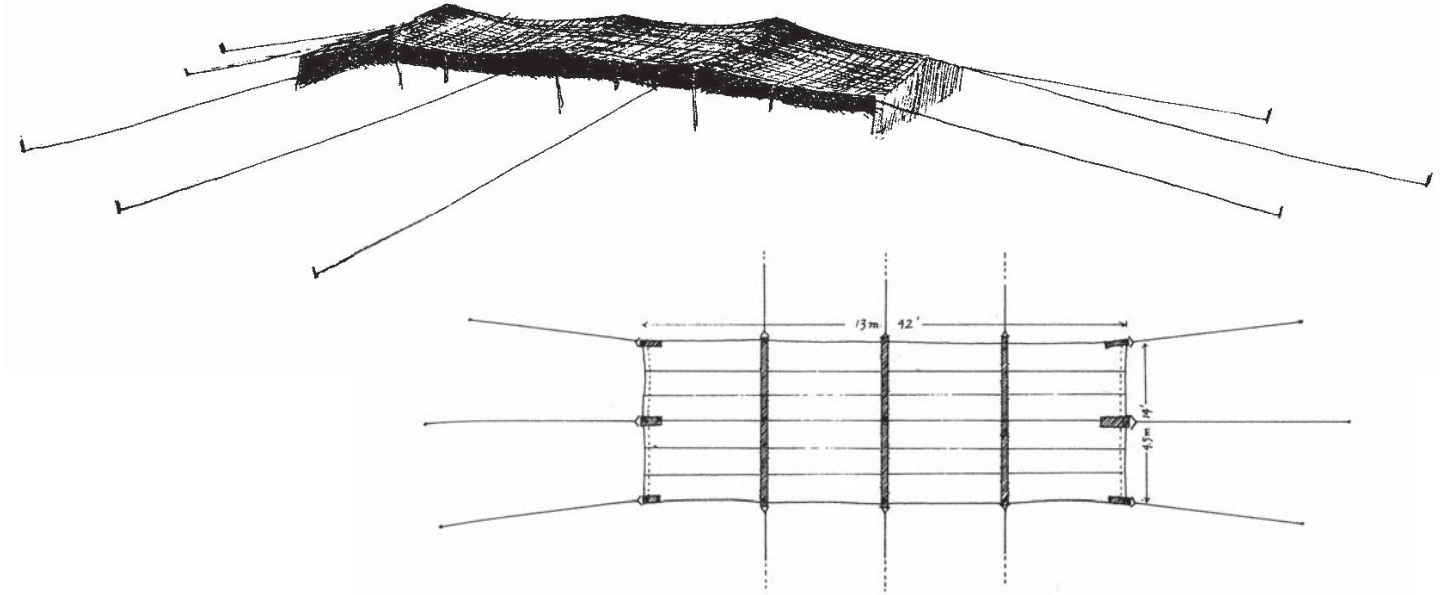

1.11 The Black Tent

1 The black tent of the Bedouins, a drawn perspective and a projection of the roof. (Faegre 1979, 22&19)

The black tent is the tent of the nomads. Torvald Faegre, the author of “Architecture of the nomads”, describes the vernacular tent architecture in detail. In his book, the black tent is the first type of tent mentioned; it is the tent of the Bible. Probably originating from Mesopotamia, the black tent is the tent of the Jews and the Arabs and also the tent of hundreds of other tribes all the way from Northern Africa and Arabia to the east of Tibet. (Faegre 1979, 1–25)

The black tent lives with the family living in it; the tent’s life ends together with that of the family. The size of the tent depends on the wealth of the owner. The structure of the tent has evolved for thousands of years along with the lifestyle of the nomads. It is transported according to the needs of the dwellers and their herd; in need of water and food, as well as following the seasonal changes. Carrying it requires only two people, see the structure in figures above. (Faegre 1979, 1–25; Kronenburg 1995, 17–19)

The fast and far traveling nomads of the nomads - the Bedouins - inhabit the traditional regions of the black tent: Arabia, parts of Syria, Israel and Iraq. The figure above shows the most widespread type of black tents, the western type black tent. It is the tent of the Bedouins, the people

of the tent. The Bedouins call it the house of hair. (Faegre 1979, 1–25)

The structure is tensile. It uses a minimum of material. The roof of the tent plays the main role. It is stretched over poles erected in three rows and fastened to the ground with anchor ropes and guy ropes. Two, three, even four columns of poles are used. The rectangular cloth can exceed the length of 20 metres in the largest of constructions. In addition to the roof fabric, a wall fabric is suspended along the perimeter of the tent. The wall fabric can be buried to the ground or if needed, rolled up for air to breathe in. (Bahamón 2004, 32–33; Da Cruz 1996; Kronenburg 1995, 17–19)

In black tents, the roof, the walls and the floors are woven. The fabric of the black tent gets its strength from the goat's hair, which is spun and woven to form a piece of cloth. The cloth is the modular unit of the black tent. Several clothes sewn together form a rectangle - the cover of the black tent. Sometimes combined with other material, wool, cotton, hemp or camel hair, the fabric is resistant to tearing, smooth and water repellent due to the fibres' natural oils. The life span of a strip of cloth is approximately five years. The roof is constantly renewed from the top so that the strip touching the ground is the oldest part, and also, in the most worn out condition. (Faegre 1979, 1–25; Kronenburg 1995, 17–19)

The name of the black tent comes from its covering material: the black, sometimes brown goat hair fabric. The covers vary greatly in style, even within a single tribe. Traditionally, the women wove the fabric and took care of the mounting of the tent, whereas men were the owners of the tent and took care of the placing of the main poles. For children, were left the ropes and the fastenings. All this was done in a strictly organized manner. (Faegre 1979, 1–25; Kronenburg 1995, 17–19)

1.12 The Yurt

The yurt is Asian correspondent of North American tipi. The origin of the yurt is unknown, but it was commonly used in the Central Asian Steppes from Siberia and Mongolia to Iran and all the way to the western Anatolia in Turkey. The yurt has remained unchanged for centuries. According to some estimates, the dwelling was in used by the Mongol tribes already some 2500 years ago. (Faegre 1979, 79–98; Habermann 2004, 18–45, Kronenburg 1995, 19–21)

The yurt is easily movable. It is transported by horses, camels or yaks on a platform or with a cart if the yurt has a wealthier owner. The mounting of the tent takes less than one hour. Used in steppes, desert and mountain areas, it is suitable for the seasonal movement of the tribes. The herding tribes that also hunted and were familiar to the horse, occupied these easily transportable dwellings. The most known of them were probably the mongols of Ghengis Khan. (Faegre 1979, 79–98; Habermann 2004, 18–45, Kronenburg 1995, 19–21)

Depending on the region where a yurt comes from, its structure is based on slightly different solutions. The wooden parts are made by men, whereas women make the felt covering. The yurt consists of several parts in a simple, demountable structure, see figures below. This cylindrical dwelling has a lattice frame, which forms a circular wall. The roof poles form the top of the construction - a Kirghizian dome or a Mongolian cone. A door frame and a woven wool tension band around the wall tie the wall lattice into a solid structure. The wall supports the roof structure. This self supporting frame structure carries the covering consisting of several layers of felt. This construction can be lifted up and carried short distances as a whole for example for cleaning purposes. (Faegre 1979, 79–98; Habermann 2004, 18–45; Kronenburg 1995, 19–21)

2 The Mongolian yurt, a plan and a sectional perspective.
A non-structural felt covering clads the self-bracing structure.
(Kronenburg 1995, 20)

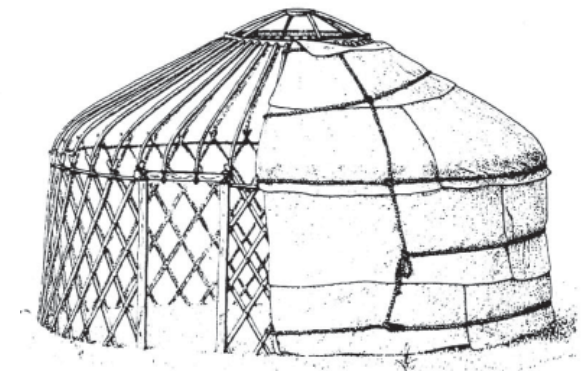
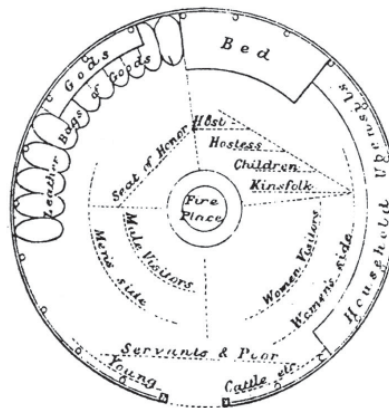

Woollen felt covers the yurt, nowadays also canvas is used. Since felt has little tensile strength, the self supporting wooden frame is needed. Pieces of sheep felt are carefully placed on the frame to ensure a weatherproof enclosure. All the joints overlap each other; up to eight layers can be used to make the roof watertight. The whole is bound onto the frame with ropes crossing each other in symmetrical patterns. Different finishing treatments of the material help to cope with the demands of the seasonal climate changes. An essential example is oiling, which makes the water fall off the surface. The cover's borders may also be coloured or decorated for visual impact. (Faegre 1979, 79–98; Habermann 2004, 18–45; Kronenburg 1995, 19–21)

1.13 The Tipi

The tipi, familiar to everyone, is the traditional, demountable dwelling of the Native American inhabitants of North America. The first written record of the tipi is from the 1540's. This lightweight, conical structure was further developed due to the introduction of the horse from the 17th century onwards: When the tribes left their settled lands to lead the nomad life and to hunt buffaloes, an easily movable structure, such as the tipi, was necessary. (Faegre 1979, 149–161; Kronenburg 1995, 16–17)

Varying in style, the tipis have a common, standard structure found in all of them: the frame, the cover and the attachments. Tipis are made, owned and erected by the women of the tribe. Men are responsible for the decorations of the outside surface of the cover. (Berger 2005, 20–24; Habermann 2004, 18–45; Kronenburg 1995, 16–17)

The mounting of a tipi is simple. Three or four poles form the main frame, tied together at the top. Subsidiary poles are added between the main poles, and all this is covered with a pattern made of buffalo hides or, 1900th century onwards, canvas fabric. Once mounted, the open seam of this heavy, semicircular pattern is pinned to wrap the cover tightly around the frame. Finally, the ground attachments at the hem of the cover secure the tipi from collapsing in the wind. The whole structure is mounted in less than half an hour. (Berger 2005, 20–24; Habermann 2004, 18–45; Kronenburg 1995, 16–17)

The tipi cover has multiple functions. A part of the cover is left open to serve as the entrance. Adjustable flaps are used for ventilation and wind guides at the top and as doors at the bottom. The lining of cloth inside the tipi functions as insulation, helping to cool the tipi in the summer and to keep it warm in the winter. The buffalo hide cover lasts up to two years. Along

the practical, there are also the symbolic values: Decorations on the cover and the inside linings tell about the beliefs of the tribe, mark the position of the dweller or work as decorative elements. (Faegre 1979, 149–161)

3 The North American tipi, a perspective and patterns of the covering (in skin and in canvas).

The non-structural covering is supported by the tipi framework.

The Tipi reminds us of the kata of the Lapps of Scandinavia, "kota" in Finnish. (Faegre 1979, 156)

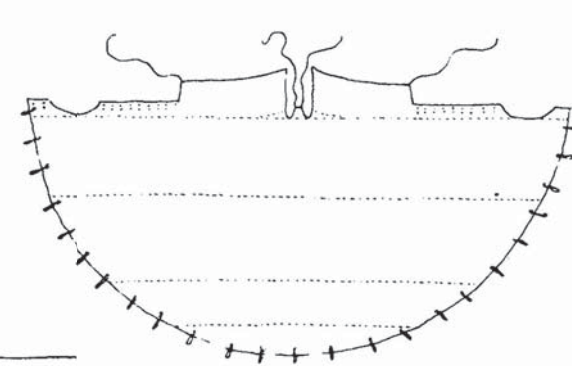
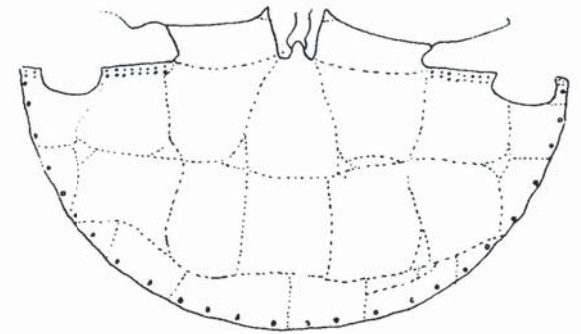
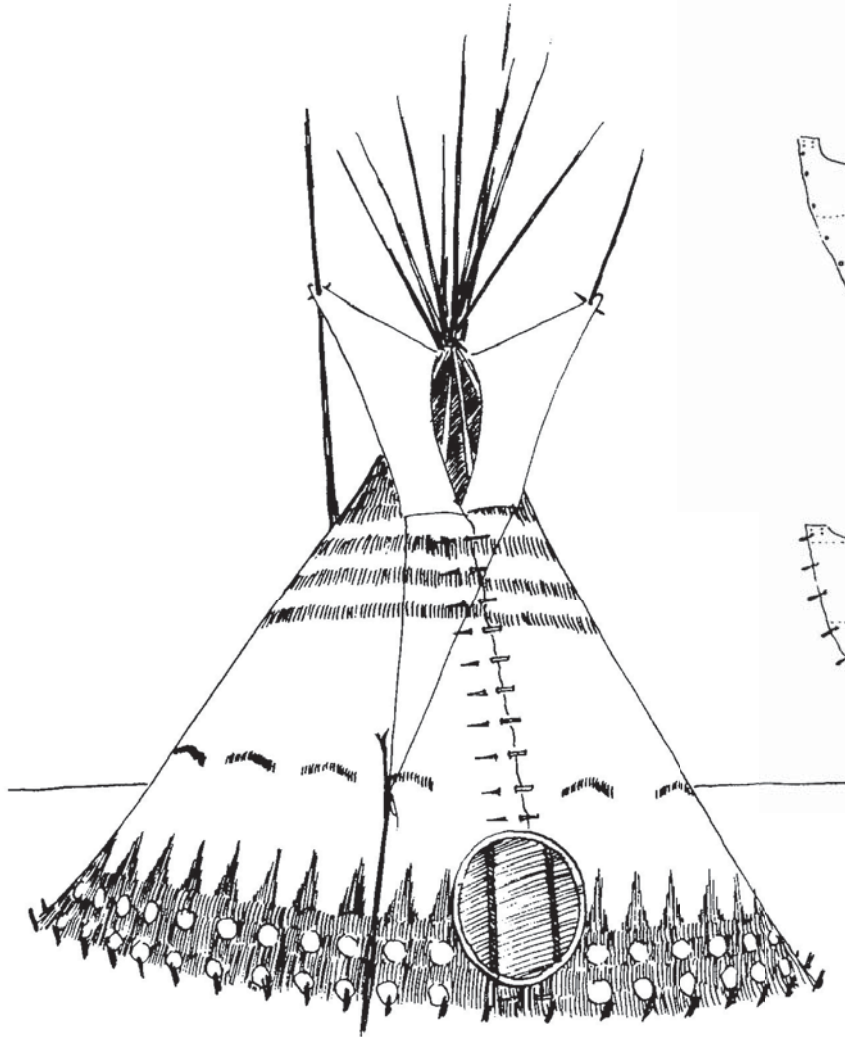

2 From Tents to the 20th Century

2.1 Early Examples

The ability to construct lightweight structures and the availability of materials for such constructions appears fragmented in the history of western architecture. Early civilizations developed in favorable and stable climate conditions in the Mediterranean, where portable solutions were not often needed. (Kronenburg 1995, 27–37)

2.1.1 Velaria over the Colosseum

One of the first appearances of textile in the history of western architecture comes from the Colosseum of Rome. Built between AD 70 and 82, this building for entertainment seated 50 000 spectators and was used for an imaginative array of events. It is supposed to have required a variety of demountable structures for its performances. It is believed that the building was covered with a retractable textile sun shades called “vela”. The Velarium structure was erected by sailors familiar with the techniques involved. Suspended from horizontal masts with a support structure of vertical masts and stay ropes like in sail ships, these textile panels are early examples of lightweight textile structures, see figures below. (Kronenburg 1995, 27–37; Berger 2005, 27) The later examples show that textile is used for very similar purposes today.

4 The Velaria of the Colosseum reconstructed, a perspective and a detail. This shade structure was retractable. (Berger 2005, 27)

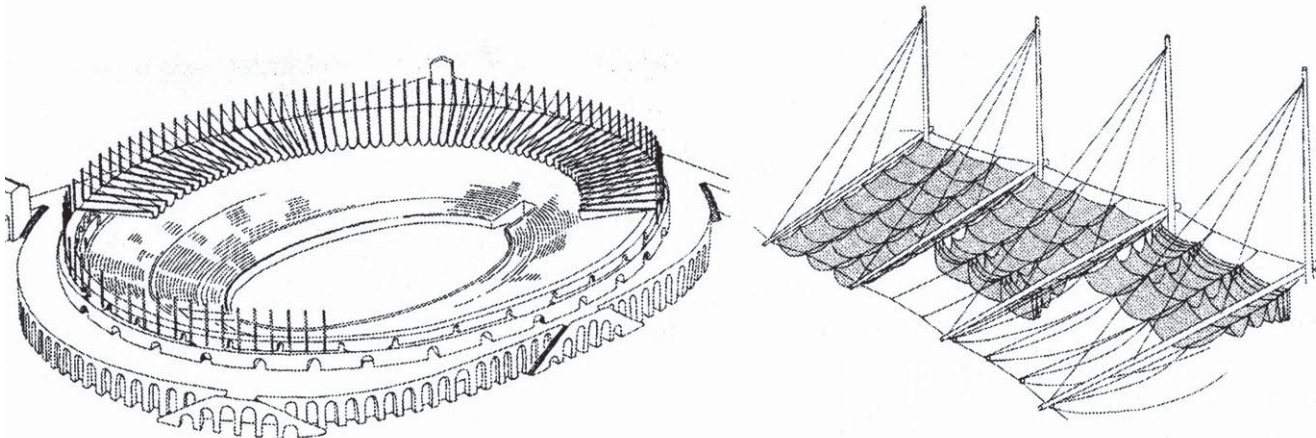

2.12 Royal Court Tents

Tents were familiar to the royal courts of Europe. The royal courts have their share in the development of textile architecture through the development of temporary buildings for the purpose of entertainment. The courts of the Renaissance and the Baroque times often hosted performances, see picture 8. They demonstrated their power by arranging happenings all over the empire. Temporary, transportable construction was suitable for such actions, and textile a suitable material. Along with the temporary building type, also the development of the theatre was strongly affected by the courts of Europe. (Kronenburg 1995, 35–41; Otto et. al 1982)

One example of the tents of the royal courts of Europe is related to the court of English monarch Henry Tudor VIII. In his favour, in 1520, a large banqueting house was erected for a diplomatic meeting in Calais, in Northern France. This was a circular, conical tent of 37 metres in diameter and 40 metres of height, in figure below. What was special about it, was the temporary function and the impressive scale brought together in this construction. Unfortunately, the construction was blown down by the harsh wind of the English Channel before the happening took place. (Kronenburg 1995, 35–41)

The tent itself was a spectacle. The central mast supported a double skin roof, where the outer textile was a weatherproof canvas, and the inner one a decorated fabric painted to look like the sky. The perimeter of the building was made of timber and covered with decorated canvas. Three floors of galleries overlooked the centre stage of the tent, where everything was to take place. All this was lit with candles on beautiful chandeliers, waiting for the guests to arrive. (Kronenburg 1995, 35–41)

5 Henry Tudor VII's conical tent, a banqueting house in Calais, France, in 1520. (Kronenburg 1995, 36)

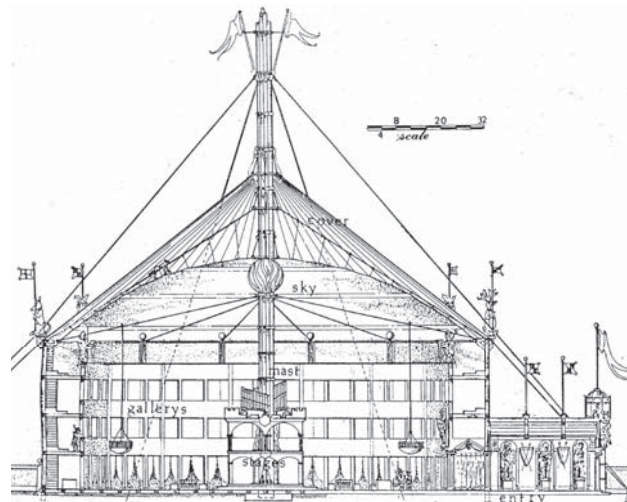

2.2 Industrialism and New Possibilities

After the traditional textile architecture of tents, it took a long time for the material to appear in architecture in a notable role. As we have read, few recorded examples of the use of textile exist in the early history of western architecture. Some of the few examples are related to military purposes, like we see in the figure 7. Textile material started to appear more often in architecture towards the second half of the 19th century.

The end of the 18th century and the 19th century developments form the basis of textile architecture. The industrial and social revolutions of the 18th century resulted in general cultural confusion. The new situation brought about a new perspective. The old world no longer existed and architecture was searching for new means to express the new situation; new building tasks instead of the monumental architecture of churches and palaces and new technology to achieve all this. Large halls, office buildings, and private dwellings became the new tasks of architecture. The most important environments for the future development of textile architecture were the exhibition buildings reflecting the new capitalist society and its possibilities and the factory buildings forming the productive basis. These were the environments, where new techniques were tested and new materials produced. (Beckh & Barthel 2009; Berger 2005, 8–19; Norberg-Schultz 1975, 169–185)

The construction techniques evolved with the invention of new materials, especially in England, France, Germany and America. Cast and wrought iron were developed in 1767 and 1784 and soon adopted from railway and bridge construction to the use in buildings. Chains in suspension bridges from 1817 onwards were replaced by iron wire cables from 1831 onwards. By the mid 19th century prefabricated iron components became important exported goods. New were the skeleton structure and the curtain wall facade. In England, the taxation of glass ended in 1845, which resulted in several glazed constructions. Concrete construction, developed starting from the end of the 18th century, was a standard technique by the beginning of the 20th century. The new materials, cast and wrought iron, structural steel and steel cables, concrete and glass, all attributed to the possibilities of constructing efficient, large span structures for the new purposes of architecture. (Beckh & Barthel 2009; Berger 2005, 8-19; Frampton 1980, 12–29) These structures are present also in textile architecture, as we will learn later.

Textile industry lead the industrial development. At the same time with the development of construction materials and techniques, the textile industry became a large-scale activity. The development started from England, where towns with “the factory, the railway and the slum”

(Mumford 1961, 458) were formed to house all this. The production needed fireproof buildings and the invention of multi-storey mills followed. (Frampton 1980, 12–29)

The first patents for coating of textiles were obtained in the 18th century. The spinning jenny and the steam powered looms were invented by the end of the 18th century. At this point, textiles were of natural fibres. Their coatings were of different oils, and later in the 19th century, rubber mixes. The main aim was to make textiles water and wind proof. (Miraftab 2000, 24–41) the main aim was to make them water and wind tight. (Miraftab 2002, 24–41)

2.21 The Circus Tent

One example from the period of early industrialism is the circus tent. In one hundred years, starting from the second half of the 19th century, this portable type of a building was developed to its final form in Europe and in America. The first circus tents were developed to shelter the performers and the audience, and to separate the non-payers from the ones who payed. The form of this entertainment and the constructions housing the events combine the former courtly venues, the new ideal of democratic society and the new technologies brought about by the industrial innovations. It brought spectacle to the reach of everyone willing to pay. The structures remind us of the banqueting houses of the Tudor Court. (Habermann 2004, 28–29; Kronenburg 1995, 35–41)

There are two basic types of circus tents. One type of structure has an independent, self-standing timber or metal frame onto which a covering skin, usually canvas, is placed. The other type is a tensile structure with a mast supported, tensile textile roof enclosing. These two different structures have their own advantages. The framed type works well in limited city sites and hard grounds. Its plan contains all the structure; no outside fixtures are needed for the self-supporting structure. The tensile tent, instead, is good for large open areas. It enables larger span structures, but requires the fixing of the structure to the ground. The two famous examples of these two types of structures are the framed tent of the Cirque Palisse (1911 onwards) and the tensile structure of the Barnum and Bailey Greatest Show on Earth from the turn of the 20th century (1897 onwards). (Kronenburg 1995, 35–41)

A non-exhaustive list related to the maturation of light weight structures

4000 years ago	6 top left: suspension bridges, Himalayas, bridge from Assam-Tibet border in plaited bamboo (Otto 1976, 23)
2000 years ago	bamboo rope bridges, China
2000 years ago	aviation and kites, China
~ 700 BC	tents in Assyria
500 BC	umbrella, Asia
	military tents, Persia, Greece, Rome
1st century AD	7 top middle: Roman military tents, relief on Trajan's Column (Habermann 2004, 24)
70-82 AD	Colosseum and first retractable tension roof in canvas, Rome
100 AD	China and the invention of wrought iron, wrought iron chain bridges
1300	open court tents, Iran
1655	Swiss guild sanitary tent, Basel
1700-	Cayley's man carrying glider
1800-	Lilienthal, Wright brothers, first tries in aviation, protos for heavier than air flying machines
1700's	the invention of wrought iron in Europe, first large span bridges
1770–1780	garden tents of Turkish fashion, Versailles Palace
1700–1800	Conestoga covered wagon, in settlement of the North America west
1700th century	8 top right: garden tents in Versailles, France (Habermann 2004, 27)
1837	British Colonialism, emigrant tents, settlement at Holfast Bay, South Australia
1840's	abolition of glass tax resulted in constructions with glass, arcades, atria
1850's	festivities and tents, coronation of the king, Clapham, England
1849	largest span bridge of the time, collapsed, Wheeling, Pennsylvania
1854	portable army tents, Joseph Paxton for the Crimean War
1903	9 middle left: Alexander Graham Bell and tetrahedron kite, silk fabric cover (Otto 1976, 24)
1929	George Washington suspension bridge Otmar Amann in New York
1937	Le Corbusier and Pavilion de Temps Nouveaux, Paris World Fair
	10 middle right: World War I, portable aeroplane hangars, three-pin arch, canvas (Kronenburg 1995, 54)
1944	Pier Luigi Nervi, precast concrete element, hangar in Orbitello
1950	Fritz Leonhardt, span bridge, stay cables to stabilize for wind
1953	Nowicki/Severud, significant cable net saddle shape structure, Raleigh Arena
1954	Frei Otto's book The hanging roof, first documentation on the theme
1954	Buckminster Fuller and air-transportable, Dacron-clad helicopter hangars
1959	Lev Zetlin and Utica bicycle-wheel cable-structure
1955	Frei Otto, Shade sail music pavilion, Kassel garden show, Germany
1957	Frei Otto, Tanzbrunnen, Cologne garden show, Germany
1958	Felix Candela and hyperboloid concrete shell, Mexico
1960's	Cedric Price, Inter Action Centre in Kentish Town, London
1960's-	Heinz Isler's concrete shells
1964	Frei Otto: sails in Swiss National Exhibition, Lausanne
1964	11 bottom left: Kenzo Tange, Olympic National Stadiums, Tokyo, semirigid steel shell cablenet roof (Berger 2005, 36)
1965	Astrodome, trussed steel lamella grid dome, acrylic panel covering
1967	Tensile Structures by Frei Otto, the standard of the theme
1967	Frei Otto and Rolf Gutbrod: German Pavilion for Montreal World Fair
1967	The first retractable roofs, Otto: Bad Hersfeld; Taillibert: swimming pool of Boulevard Carnot, Paris & W.B. Morgan and Wilson, Morris, Crain & Anderson
1968	Frei Otto the Mannheim Garden Exhibition gridshell
1972	12 bottom right: Bechnish & Partner, Frei Otto, Leonhardt & Andrä, Munich Olympia Roof, urban scale cablenet (MacDonald 2001, xii)
1983	Munich Olympia site, ice-skating hall by Ackermann and Schlaich
1984	Fraser and Roberts with Horst Berger Riyadh stadium, Saudi Arabia
1986	Canada Place in Vancouver by Eberhard Zeidler symbol for the city for 1986 Expo
1990	new era of retractable roofs Schlaich Bergermann und Partner, arena of Saragosa, Spain
1992	Seville Expo, computer influenced examples like Grimshaw membrane facade

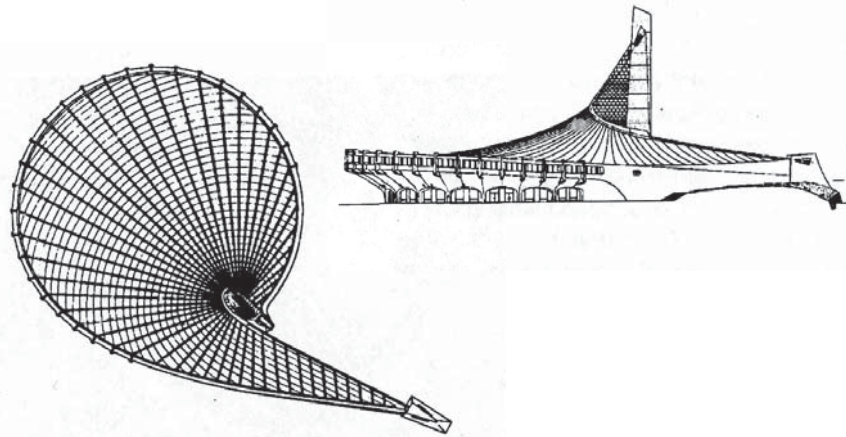
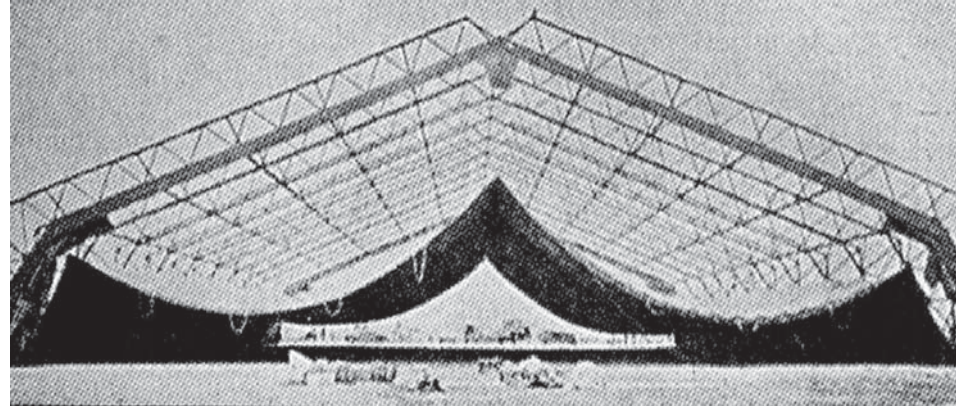
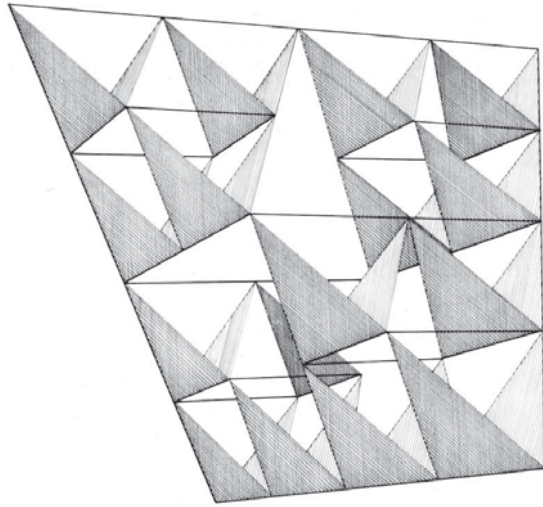
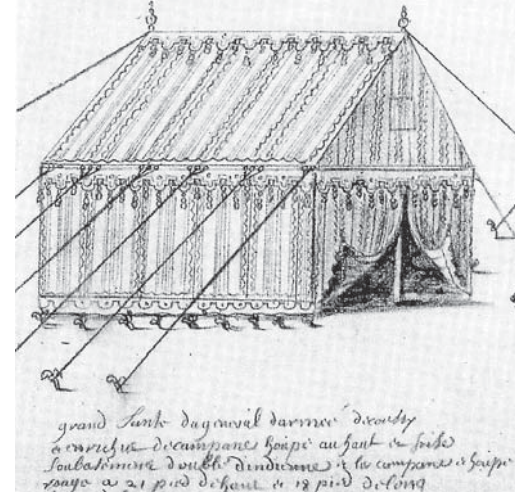

3 The 20th Century Maturation

Textile architecture of the 20th century can be seen together with the development of construction structures. The light weight tensile membrane structures developed strongly after the World War II. Later followed the pneumatic structures. Textile and fabric were also used in structures where they had no load-bearing role, present in figure 10. Other applications related to the development of light weight structures were inventions related to aviation, see an example in figure 9.

Also the development with textile materials and coatings accelerated in the 20th century. New fibres were invented and several new polymers, synthetic rubbers and adhesives for coating and lamination of textiles were developed. These man-made materials were developed to surpass the properties of natural fibres. The cellulose based regenerated fibres became commercially available in the beginning of the 20th century, first of them viscose rayon. Then followed the synthetic fibres, first of them nylon, available in 1939, just in time before the World War II. The developments of textile use in architecture clearly accelerated after the World War II. The extensive use of textile and fabric for the purposes of the military affected the interest towards the use of these materials for the purposes of civilian life as well. (Byrne 2000, 1–23; Miraftab 2002, 24–41)

The following chapters tell us the parallel stories of textile and fabric architecture and related construction structures of the 20th century. Two structural main divisions exist, the lightweight membranes or cablenets and the pneumatic structures. We will learn about these two categories separately. In addition to these, a fresh application - namely the invention of textile facades - concludes our study. The buildings and structures we will describe belong to the groups of pioneering and/or significant solutions. After discussing the early developments of the 20th century, a short introduction to the design processes involved in textile architecture is given before moving on to the next chapter.

3.1 Fabric Membrane and Cablenet Structures

The development of tensile light weight structures has its roots in large span suspension bridge construction, see an early example in figure 6. From bridges the development spread over to buildings, an example is seen in figure 11. The first person to experiment with cable supported tensile roofs was Russian engineer Vladimir Shukhov, who designed pioneering steel structures for the All-Russia industrial and art exhibition in Nizhny-Novgorod, Russia, 1896. Early applications of tensile light weight structures in the 20th century often had rigid covering material, such as thin steel sheets. It was German architect Frei Otto, who started the development of tensile structures with flexible textile and fabric coverings in the middle of the 20th century. (Berger 2005, 20–39)

Frei Otto began experimenting with light weight tensile and membrane structures after returning from the World War II, where he had served as fighter pilot. The years as a prisoner of war, working in charge of a construction team and repairing damaged bridges, led him to develop an interest towards structures using the minimum of material. (Berger 2005, 20–39) His work introduces us to the development of light weight tensile structures. The following examples describe tensile fabric membrane and cablenet structures through Frei Otto's designs.

Tensile fabric membrane and cablenet structures

Tensile fabric in membrane structures and cablenets is designed to be a minimal surface. A form finding program is used in order to find the final form of the structure. The form of the compressive primary structure, the tensile fabric's support points and the chosen membrane surface form are the parameters determining the resulting specific shape of the membrane. These dynamic tensile structures adjust to differing loads due to their elasticity. The simple tensile membrane form is a four point structure with at least one point at a different level from the three other points. Small to medium size structures can be achieved with fabric membranes. Larger constructions have an integrated cablenet system that helps transmitting heavy dead and live loads. (Berger 2005, 40–53)



13 The four point double curved saddle shape structure of the Kassel music pavilion. Frei Otto and Peter Stromeyer, 1955. (Otto 1982, 64)

3.11 Music Pavilion, Kassel

The early realized experiments of Frei Otto are tensile membrane structures of small and medium size. One of the simplest designs was the Music pavilion shade sail for the 1955 Federal Garden Exhibition in Kassel, Germany. This pure structure was a minimal surface with four points creating a saddle shaped membrane roof, see figure above. Two thin compression masts created the two high points and tension cables the two low points, the four points necessary for tensile structure construction. The cotton fabric membrane was tensioned between these points. The Kassel canopy was further developed in several exhibitions, and tensile membrane structures became common for such purposes. (Otto 1982, 28–52)

3.12 Tanzbrunnen, Cologne

The elegant design of Tanzbrunnen for the 1957 Cologne Federal Garden Exhibition was developed form of the first sail shapes of Frei Otto, in figure below. This platform for dancing was covered with a roof of a wavelike form. Here Otto integrated cables to the membrane. A central cable ring carried the radial ridge and valley cables spanning to the six high and six low points of the structure. The cotton fabric membrane was tensioned between the center, the high points supported by compressive, tilted masts and the low points tensioned with cables and concrete anchoring blocks. The edge catenaries determined the star-like shape of the whole. (Habermann 2004, 18–45; Otto 1982, 28–52) The roof canopy was like dress draped in the whirl of dancing.

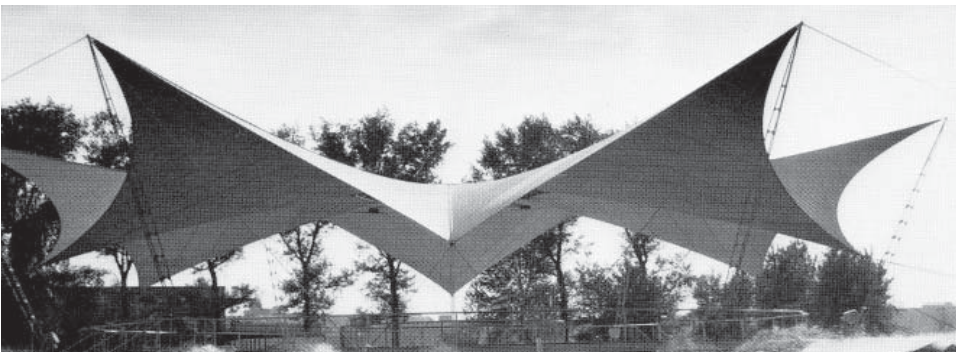

14 The circular saddle shape of the Cologne Tanzbrunnen. The upward curved ridge cables carry the weight of the structure and snow loads. The downward curved valley cables carry wind suction loads. The fabric membrane carries both the upward and downward loads. (Otto 1982, 64)

3.13 German Pavilion for Expo '67, Montreal

German Pavilion at Expo '67 German Pavilion for the Montreal World Fair was Frei Otto's first opportunity to explore his inventions in large scale. He won the competition for the exhibition architecture with his colleague Rolf Gutbrod. Unfortunately, the building collapsed under a snow load five years after its construction. However, the pavilion accelerated future developments in the field of tensile cable-net construction: it had a large, spacious scale, present in the figure below. (Berger 20–39, Habermann 18–45, Kronenburg 1995, 49–51)

The free-form cable-net of the temporary pavilion of Germany set new standards for tensile building construction. The cable-net roof mounted and descended like a landscape in the Montreal exposition area. Seven masts of different heights supported a tensile cable-net structure rising to high points and reaching the ground at the anchoring low points. The polyester fabric skin hung from the cable-net as a secondary element. This was the unfortunate decision that resulted in the failure of structure. However, the construction was a success with its landscape-creating silhouette. (Kronenburg 1995, 49–51)

Frei Otto perfected the design of the German pavilion and the cable-net structure in general in the realization of the Olympia Roof for the Olympic Games in Munich 1972, see figure 12. The execution doesn't involve fabric in the structure, but the design is considered the masterpiece of tensile cable-net structures. These two large structures lead the way to new possibilities in tensile construction. (Berger 20-39, Habermann 18–45, Kronenburg 1995, 49–51) This development continues today.

15 The organic, free-form cable-net structure of the German Pavilion in Montreal. The structure was prefabricated and demountable. Frei Otto, 1967. (Otto 1982, 66)





A Monsieur de Supta de S^{te} Fond, de Plusieurs Academies.
L'Expérience d'aujourd'hui, le 24 Septembre, 1783, en présence de Louis d'Orléans, de la Société Royale et de plus de 300 autres personnes. Les M^{rs} de Montgolfier ont en effet de St. Pierre de Muret, sur le territoire de France, inventé un moyen de s'élever dans les airs, au moyen d'un ballon rempli d'air chaud, et d'un panier suspendu dessous. Ils ont été les premiers à s'élever dans les airs, et leur ascension a été accompagnée de la plus grande curiosité. On a vu de plusieurs personnes monter dans le panier, et de plusieurs autres s'élever dans des ballons remplis d'air chaud, et de plusieurs autres encore. On a vu de plusieurs personnes monter dans le panier, et de plusieurs autres s'élever dans des ballons remplis d'air chaud, et de plusieurs autres encore. On a vu de plusieurs personnes monter dans le panier, et de plusieurs autres s'élever dans des ballons remplis d'air chaud, et de plusieurs autres encore. On a vu de plusieurs personnes monter dans le panier, et de plusieurs autres s'élever dans des ballons remplis d'air chaud, et de plusieurs autres encore.

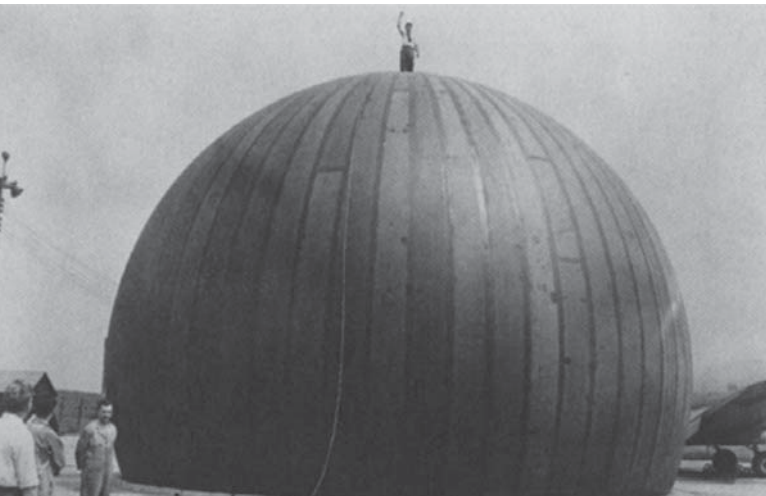
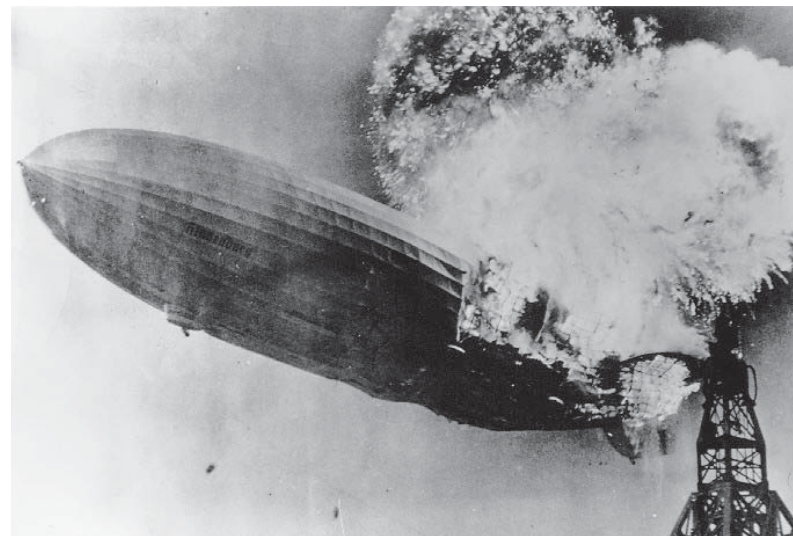
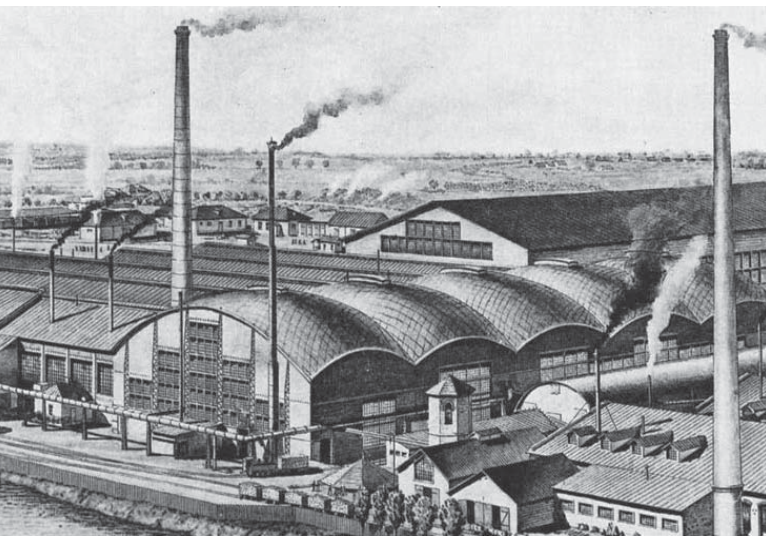
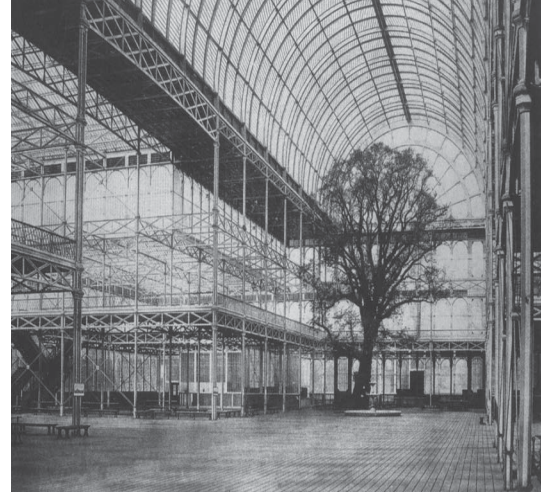

A non-exhaustive list of phenomena related to the maturation of pneumatic structures

3500 BC	skin sails, Crete
	Assyrian warriors crossing rivers on air-inflated goatskins
~360 BC	dome of Hagia Sophia
	air-inflated animal skin mattresses and underwater breathing devices, Greece, Rome
127 AD	Pantheon, concrete dome, Rome
800 years ago	Chinese hot air balloon
1436	Florence Cathedral Dome, Brunelleschi
1532	16 top left: Roman air-inflated animal skin mattress for river crossing (LeCuyer 2008, 11)
15 th century	Leonardo da Vinci: inflated pig bladders creating space, parachute
1783-	17 top middle: Montgolfier brothers in France, first man-carrying flights (LeCuyer 2008, 12)
	paper lined cotton bag inflated with heated air, carrying duck, rooster and a sheep, man-carrying flights
	in hydrogen filled rubber impregnated silk balloon
	Napoleon's troops and aerial observation balloons
19 th century	Montgolfier: dirigible cigar-shaped airships, adopted for military purposes
1849-	Austria against Venice, bombs using small hot air balloons, military applications until the World War I
1851	18 top right: Joseph Paxton's Crystal Palace at the Great Exhibition of England, barrier between man and landscape vanished, lightness in building (LeCuyer 2008, 15)
	Cutty Shark, culmination of sail boat development
1869	Dunlop: patent for high-pressure tires
1888	Count Zeppelin: patent for airship design
1891	19 middle left: first double curved gridshell, Nizhny Novgorod, by Shukhov (Beckh&Barthel 2009)
1886	Frederick William Lancaster: patent for first pneumatic building
1917	First World War and airships
1920's-	Buckminster Fuller: lightweight structures and constructions; study on tensegrity and geodesic forms, approximations of pneumatic forms, bubbles
1924-	Wallis: R100 Airship
1936-1937	20 middle right: world's largest airship Hindenburg exploded on its first flight in 1937 (Pasquerella 2010)
	World War II: exploration and defense with balloons, airships, temporary buildings
	Post World War II development: MUST deployable combat support hospital, inflatable dual wall, Dacron enclosure, mine sweeping airships, inflatable temporary buildings
1940's	21 bottom left: Walter Bird: pneumatic radar antennae and building enclosures, US Air Force and low pressure air-supported radomes (LeCuyer 2008, 21)
1956-	Birdair Structures: pneumatic storage, shelters, greenhouses
1959	Boston Arts Center pneumatic roof cushion in vinyl coated nylon fabric
1960	US Atomic Energy Commission, portable, air-supported pavilion
1960's-	22 bottom right: Archigram of London, Independent Group of America, Haus de Rucker Co. and Coop Himmeb(l)au of Vienna, Utopie and Situationists of Paris, Haus Rucker Co. of XXX :: radical architecture, visionary air structures/Haus de Rucker Oasis No. 7, cell for living (LeCuyer 2008, 25)
1960's-	The US Space Program and NASA: meteorological, communications and defence purpose long life satellites
	satellite balloons, Echo I and II communications satellite
1962	Buckminster Fuller: pneumatic dome over Manhattan, environmental envelope
1960's	Frei Otto: Tensile Structures: "air, the most lightweight of all building materials"; High Voltage Research Lab in Cologne; air as structure, cushion and composite pneumatic structures,
1965	Astrodome, trussed steel lamella grid dome, acrylic panel covering
1967	Fuller's steel framed geodesic US Pavilion at the 1967 Montreal Expo, climatic skin
1968	The first dome structure to cover a full size stadium, Astrodome in Houston, Texas
1968	Frei Otto the Mannheim Garden Exhibition gridshell
1968	Architectural Design and Pneu World overview
1970	The Arctic city of Frei Otto and Ewald Bubner
1970	Decade culmination in Osaka 1970, large collection of pneumatics:
1970	American Pavilion, Osaka, Japan, the first low profile large span air supported roof
1970	Foster Associates: Computer Technology Ltd's temporary office
1971	Frei Otto: Arctic city air-supported envelope, non-building
1975	Pontiac Silverdome near Detroit, air-supported Teflon coated fibreglass membrane
1976	Thomas Herzog: book on Pneumatics
1980's-	attention towards air-inflated cushions and more sedentary constructions

3.2 Large Span Gridshell and Air-structures

A dome is a structure reoccurring in textile architecture. Prehistoric dwellings had stick frame domes, and later, brick domes. Early civilizations were familiar to compressive brick and concrete dome structures, but it was not before the industrialized, late 19th century, that the large span domes became common again. The new materials, cast and wrought iron, structural steel and steel cables, concrete and glass, all attributed to the possibilities of constructing efficient, large span structures for the new purposes of architecture. One of the famous and early examples, although not yet a dome but an arched hall, is the Crystal Palace by Joseph Paxton for the Great Exhibition of England in 1855, present in the picture 18. (Berger 2005, 8–19)

Concrete shells, gridshells in steel and precast concrete structures of the 20th century advanced the understanding of large span construction. The first light weight shells were compressive gridshells. Russian engineer Vladimir Shukhov pioneered several steel structures, among them a double curved steel gridshell clad with sheets of steel. This was a production hall in Vyksa, a steel mill building from the year 1897, present in the figure 19. Another visionary, Frei Otto, experimented with the grid-dome structure using new materials. He used a flexible fabric covering material functioning as the enclosing element of the structure. This was much later, towards the second half of the 20th century. (Beckh & Barthel 2009; Berger 2005, 8–19) Frei Otto's gridshell design, the Mannheim Multihalle, is described later in this chapter. Gridshell structures are quite rare, but will quite likely become more and more common in the future. This is due to the advanced computer aided design and manufacture available today.

When the uses of architecture demanded spans to become larger and larger, air-supported structures were found to be the answer. Fabric membrane fulfilled the need of structures with only end supports. These domes or dome shaped structures started to develop in the 1970's. (Beckh & Barthel 2009; Berger 2005, 8–19) Pneumatic structures developed in parallel with light weight membranes and cablenet structures. A brief description of the history of pneumatics enables us to understand the phenomenon in more detail.

Pneumatics has a colorful history. The early examples benefiting from gas-pressure differences are related to transportation, the conquest of the sea and the sky, both for the sake of pleasure and power. Some of the first applications of the early civilizations were skins, used as sails or air-infilled cushions to help cross rivers, present in the figure 16.

Kite balloons were used for military purposes. In 1783, the Montgolfier brothers in France managed to fly a cotton bag with heated air, carrying a duck, a rooster and a sheep, see the figure 17. Later that year, they succeeded with the first man-carrying flights with a silk balloon impregnated with rubber and filled with hydrogen. These first flights were conceived as liberating, democratic spectacles for everyone to enjoy. (LeCuyer 2008, 10–31)

The turn of the 20th century was already full of inventions related to pneumatics. Dunlop patented the high-pressure tyre in 1888. A few years later, in 1891, Count Zeppelin patented a design of an airship covered with a cotton and plastic film skin. The first architectural application came in 1917: Although never realized, English engineer Lancaster's low-pressure pneumatic campaign hospital was the first patented pneumatic building. (Chi & Pauletti 2009; Kronenburg 1995, 26–33; LeCuyer 2008, 10–31)

Military applications are the foundation of pneumatic structures. World War I and II both advanced the use of pneumatic structures. Airships were now dirigible. During that time, shelters for people and vehicles were developed, and even pneumatic decoys were used to distract the enemy. Structures for extreme weather conditions were developed, like the radar antennae by Walter Bird, present in the figure 21. These developments lead to civilian applications and the popularization of pneumatic structures. By the end of the 1950's, pneumatic structures already had applications in the everyday life: storage buildings, shelter, greenhouses and swimming pools. (Kronenburg 1995, 52–61; LeCuyer 2008, 16–31)

In the 1960's, the field of pneumatics exploded with ideas and their realizations. This was the era when pneumatics was considered as a means to move away from the elitist, monumental architecture and towards a mobile, ephemeral future. At the era of pop culture, the radical groups of the 60's – Archigram of London, Ant farm of America, Coop Himmel(b)au and Haus Rucker Co. of Vienna, Utopie and Situationists of Paris –developed idealist pneumatics projects. One example is the Haus Rucker Co.'s "Oasis No. 7", an inflated parasite cell for living, see figure 22. (LeCuyer 2008, 16–31)

The development of pneumatics blossomed in the 1970's. In Expo 70' in Osaka, several pneumatic structures were explored. The two examples described in this chapter are both from this exhibition, the anticlastic high pressure air-infilled Fuji Pavilion and the synclastic large span low pressure air-supported US Pavilion. After Osaka's exhibition, pneumatics

was applied in several large span dome constructions and for sedentary purposes. Low profile pneumatic structures replaced the large span rigid dome structures in several stadium constructions. The 1980's saw a shift towards pneumatic cushion structures. (LeCuyer 2008, 16–31) Today, pneumatics is used both in ephemeral and sedentary architecture and new materials are being employed to achieve even more purposeful structures.

Pneumatic structures

Pneumatic structures employ textile and fabric materials. In pneumatic air-structures, air-pressure acts as a compressive element to inflate the enclosing flexible membrane and to stabilize the structural form. The structure is based on the pressure difference of the inside and the outside. Both low and high-pressure applications exist. In low pressure air-supported structures, the inside air-pressure is only slightly higher than the outside air-pressure. High-pressure air-infilled structures are based on inflated cellular sections; the space for the use of people is not pressurized. The present day solutions are often pneumatic cushion structures.

23 Mannheim Multihalle.
The translucent skin lets daylight
enter the interior space.
Otto, 1975. (Otto 1982, 49)

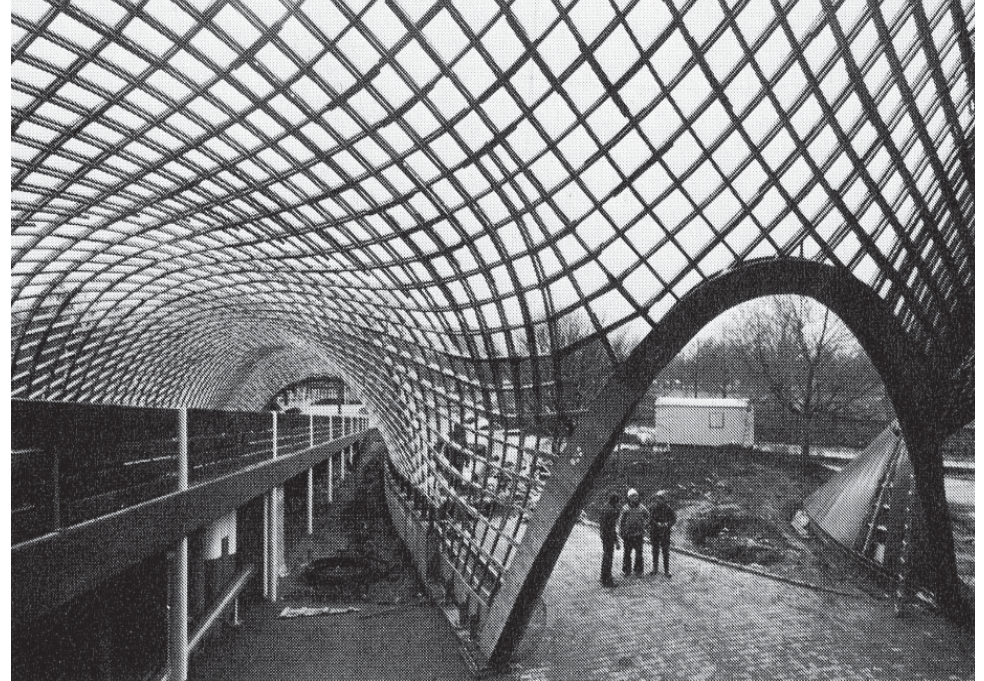

3.21 Mannheim Multihalle Gridshell Dome

One of the few gridshells of the world, the Mannheim Multihalle is the multi-purpose hall of the 1975 Garden Exhibition in Mannheim, Germany. It was designed by German Mutshler & Partners together with Frei Otto and British engineer Ted Happold. Initially the grid-dome housed indoor exhibition booths, restaurants and supportive functions for the exhibition and it was meant to be temporary. However, the structure is still in good condition and the building is used for gatherings, seminars and exhibitions. The hall is a compressive gridshell structure covered with translucent, PVC (polyvinyl chloride) coated polyester fabric, see the figure below. The orthogonal lattice timber grid is curved to form the two principal domes with the adjoining spaces. The double curved synclastic shape results in a fluid, continuous form and the choice of the enclosing material lets daylight enter inside, present in the figure above. The structure was chosen as it proved to be the only possible structure with the required form after various attempts to establish it in other ways. (Otto 1982; 140–143; Paoli 2007)

24 Mannheim Multihalle. A gridshell
is a self-standing structure. The construction starts from a two-dimensional “grid mat”, which is deformed to an orthogonal grid three-dimensional grid. (Otto 1982, 49)

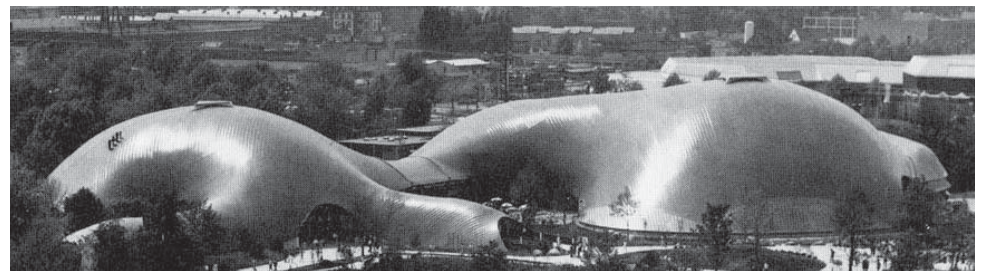

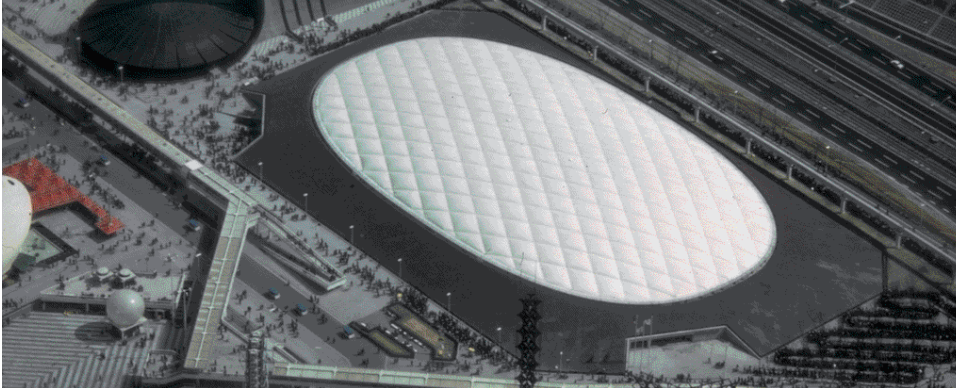

25 American Pavilion in Osaka Expo. The low profile pavilion has a cablenetting that reinforces the skin. Brody, Chermayeff, Davis, De Harak, Geismar, Geiger, 1970. (Davis&Brody/www.columbia.edu)

3.22 American Pavilion Air-supported Structure, Osaka

The American Pavilion in Osaka Expo '70, by architects Brody, Chermayeff, Davis, De Harak, Geismar and structural engineer David Geiger, is the first low profile air-supported dome. It is an enclosed, clear span structure, seen in the picture above. A clear span is optimal for large spaces where much space is needed for the audience, such as stadiums. The synclastic form of this dome inverted the hanging cablenet structures of the earlier decades, which in turn had replaced the rigid compressive domes familiar from the large span dome structures. This type of structure has had its challenges with air-pressure problems and is not in favor today. (Berger 2005, 8–19, 186-198; LeCuyer 2008, 16–31)

In the pavilion, the air pressure inside supports the roof fabric, secured by the diamond patterned cablenetting over the super-elliptical plan, shown in the plan below. The carefully designed construction has a synclastic, funicular form. This enables the compression ring on the concrete base to carry the loads, transmitted by the cablenet in a maximally efficient way. This is clearly visible in the aerial view above. The diamond-shaped cable-grid reduces one third of the weight compared to a rectangular grid. The translucent roof fabric is made of vinyl coated fibreglass fabric, a material used for space suits. (Berger 2005, 8–19, 186–198; Wakefield 2005, 98–123, LeCuyer 2008, 16–31)

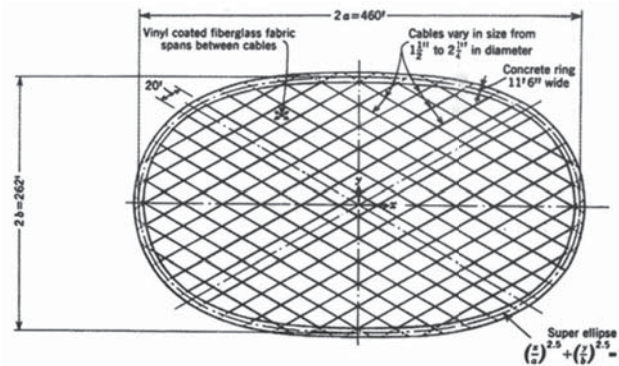

26 The roof plan, an oval shaped super-ellipse form of the American Pavilion. (Davis&Brody/www.columbia.edu)

27 The elevation of Fuji Company Pavilion in Osaka Expo. Air is pressurised within the membrane elements. Murata&Kawaguchi, 1970. (www.tensinet.com)

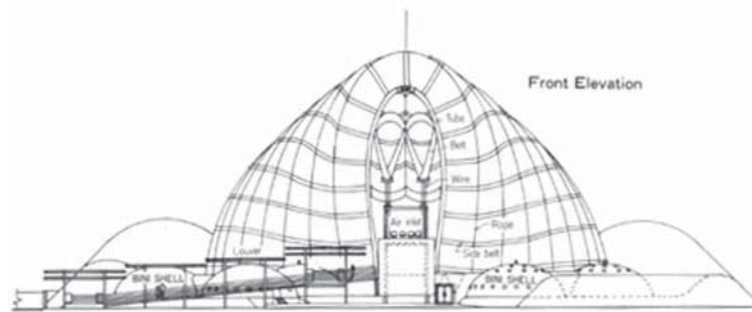

3.23 Fuji Company Pavilion Air-infilled Structure, Osaka

The Fuji Company pavilion in Expo '70 was another type of a pneumatic structure, also exhibited at the Osaka World Fair. This Fuji company's advertising sculpture was a building of an anticlastic form and air-filled structure. It belongs to the group of experimental pieces of work combining art and architecture as well as future optimistic design of the Pop Art era. It was a hybrid structure with air-filled structural parts, held together by a cablenet system of industrial belts, see the elevation above. The inflated sections were arranged to form a wagon-like shape, see the figure below. (Habermann 2005, 18–45; Tensinet 2010c)

The pavilion is the world's largest pneumatic structure of its type. High-pressure air was the compressive element carrying loads. Membrane tubes enclosed the air in. The fabric used was developed for the purpose. It was Hypalon (polyethylene synthetic rubber) coated Vinylon (synthetic polyvinyl alcohol fibre). The composite fabric had two layers attached with neoprene adhesive. The surface was further coated with PVC film to ensure air-tightness. (Habermann 2005, 18–45; Kronenburg 1995, 102–125; Tensinet 2010c)

28 The Fuji Pavilion's membrane elements were tied together with industrial belts. (www.tensinet.com)



3.3 Fabric Facades

Most of the examples of textile and fabric architecture are horizontal coverings, either roofs or enclosing structures. These structures can be seen to have reached their maturity in the 1970's and 1980's. The facades were covered with textile and fabric fairly late, in the 1990's.

3.31 British Pavilion for Expo' 92, Seville

One of the first significant applications with textile covering a facade was again from an international exposition, the Seville Expo in 1992, present in the picture below. Nicholas Grimshaw's British pavilion was clad on two of its facades with a moderately curved sail-like membrane. (Habermann 2004, 18–45) This project brings us back to the origins of light-weight structures, namely to the development of sail boats, and at the same time to the closure of our study of the roots of textile architecture.

British pavilion for Expo 92 was an elegant temporary building carrying symbols of sailing in its structure, see figure below. The building was in a single volume. Its pin-jointed tubular steel structure had varying faces; eastern water wall, western wall of freight containers and the two membrane faces of the north and south walls. These two membrane facades were clad with PVC (polyvinyl chloride) coated fabric, stretched between the repetitive facade of curved masts using structural parts familiar from sailing. (Grimshaw Architects 2010)

In the British pavilion, textile can be seen to have found its place among the other known materials of architecture, side by side with timber, stone, glass and metal.



29 British Pavilion in Seville Expo. The facade with curved steel masts, spreaders and rigging with the stretched membrane skin. Nicholas Grimshaw Architects, 1992. (Jo Reid & John Peck/www.grimshaw-architects.com)

4 Textile and Fabric Structures

Textile architecture is architecture of “skin and bones”. As fabric can only resist tension, a supporting system of compressive elements is needed. This is called a primary structure and it transmits the external, vertical loads to the ground. (Moritz 2000; Göppert 2004, 74–95) Loose-fitted and planar skins exist also; mostly in facades, independent shade screens or as cladding material. These examples are few, but textile replaces compressive construction materials more and more often.

In membrane architecture, a thin fabric skin works as a load transmitting surface in a dynamic structure. The fabric is in doubly curved anticlastic or synclastic form. Anticlastic form is based on a double curved pattern with the curves pulling to opposite directions, such as in a saddle shape. In synclastic form the curves pull in the same direction, such as in a paraboloid shape. (Moritz 2000; Göppert 2000, 74–95)

The solution of the primary structure affects the geometric composition of the membrane. Like we see from the examples already described, there are various different types and forms of primary structures in textile architecture. The framework can have many forms. The basic structures are planar or doubly curved membrane and cablenet structures. There are for example air-supported structures, arch supported applications, mast structures, primary point supported structures, ridge and valley systems, spoked wheel constructions and umbrella structures to name a few. These structures play very different roles: they can be temporary, sedentary and/or retractable. They can be made to last or to be used only once. (Moritz 2000; Göppert 2000, 74–95)

4.1 The Design of Textile and Fabric Structures

The author of the book *Fabric Architecture*, Samuel J Armijos, who specializes in fabric structures. Armijos explains the processes involved in realizing fabric architecture structures. He divides the realization and end-use processes into five steps, designing, patterning, fabric manufacturing, installation and maintenance. (Armijos 2009ab)

Fabric and architecture combines in many ways the skills of various fields. In the process, there are several aspects to consider: the client, the designers and architects and the engineers. All of them have their preferences, which most probably vary from each other. End-use requirements impose demands on the design. It should be economical in

the choice of material, components, production methods, logistics and installation as well as maintenance. (Armijos 2009bcd)

Structural fabric can be air-inflated, air-supported or tensioned to its form. In Armijos' opinion, the beauty of fabric architecture lies in the minimality of the number of its components: the primary structure, the membrane fabric itself and the components for the attachments. All the parts in the design are dependent on each other: the fabric membrane, the chosen method of fastening and the form of the structure all add up to the load bearing capabilities of the design. (Armijos 2009bcd)

The process from the principal idea to the execution starts from the design. First thing to explore is the form. Lightweight membranes are designed to be minimal surfaces. The best way to achieve structural stability is to design a double curved form for the fabric membrane. This creates pre-stress or tension to the membrane and enables it to transmit lateral loads. The second step is to decide upon the solutions related to the binding of the membrane to the other components of the structure, beams, cables or columns, frames and walls. The attachments can be either continuous or achieved by fastening points. The decision has an effect on the structural parts required: Belts, cables and ropes can be used to carry loads from the membrane to the main structural points. (Armijos 2009c)

A form finding process follows the decision concerning the fastening method. The aim is to find the most efficient structure by considering all the physical aspects of the process. There are two ways to achieve this: traditional physical modelling and computer aided design. Nowadays, highly developed software helps the processes in multiple ways. It can calculate the amount of fabric needed, define the cutting patterns and the dimensions of other structural components. It also enables the easy modification and the exploration of different possibilities. (Armijos 2009c)

When the structure is designed, its load-bearing capabilities are analysed by experienced professionals specialised in this field. When the careful calculations have been conducted and the designs approved, the patterning of the suitable fabric and its manufacturing methods are defined. After the production stage, there is still a need for determining the logistics solutions and finding the experts for the installation of the membrane. Furthermore, questions related to the end-use requirements and the maintenance of the construction, must be considered. (Armijos 2008bc)

5 A Case Study

Textile architecture is also architecture of structures. We will have a look at contemporary advanced and mature designs through six design cases. The following examples describe projects representing the already mature and advanced applications of textile and fabric in architecture. They are examples where textile and fabric structures can be seen to have developed to their full maturity, and the use of fabric materials can be considered to have reached an advanced stage. The projects were chosen based on the fact that they complement each other and give a general understanding of the common materials, different structures and architectural scales of textile architecture. The projects are described in the chronological order of their realisation.

5.1 Contemporary Fabric Architecture

5.11 Haj Terminal of King Abdul Aziz International Airport

Architect	Skidmore Owens & Merrill
Structural Engineering	Owens Corning Fiberglass
Fabric consultant	Geiger Berger Associates, Horst Berger
Structure	Array of multiple framed, mast suspended membrane tent units, kinetic structure
Fabric	PTFE coated fiberglass fabric
Area	440 000 m ²
Period	1977–1982

The Haj Terminal in Jeddah, Saudi Arabia, is the largest roof structure ever realized, see the figure below. The terminal, an open roof shelter, was built for the delight of the pilgrims arriving yearly in Jeddah on their way to Mecca for the Holy Month of the Haj. The shading roof is there to protect travelers from the heat of the Saudi Arabian desert. This is the purpose it was built for. Once a year, the enormous number of pilgrims arrive in and leave the city and up to a hundred jumbo jets may fill up the airport. The terminal was constructed to serve for a period of only six weeks in a year. (Berger 2005, 94–112)

30a The Haj Terminal in Jeddah. The open roof was an economical solution for the structure, which is used only for a short period of the year. (www.som.com)

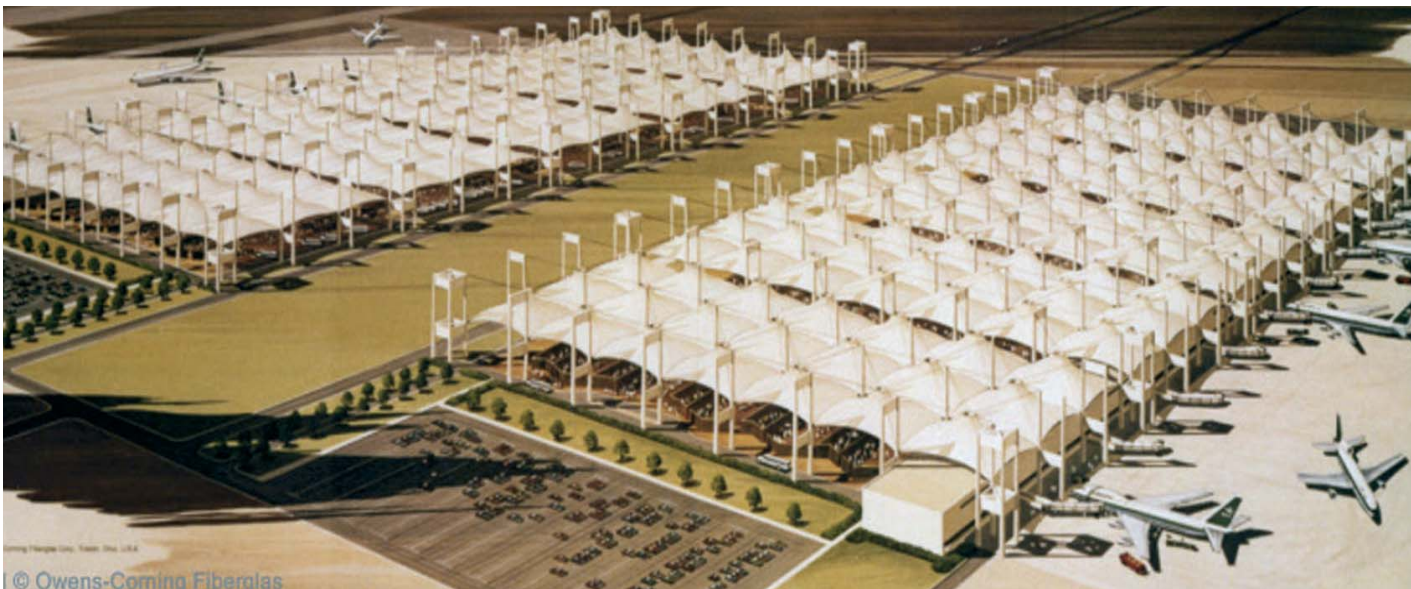

The structure has a periodic pattern, see the figure below. The building is divided into ten modules (320x137m). These modules each consist of 21 tent units (45x45m). A central access road divides the construction into two. Away from this axis, on the opposite sides, are gates to the planes. (Tensinet 2010a) The tent units in a module are suspended from high masts at the tents' corners. The interior masts of the module stand alone. The masts on the edges or at the corners of a module are in groups of two or four. This creates the repetitive structure that suspends the fabric tents. The tents are fabric cones reinforced with 32 radial cables. These cables are connected to the edge catenaries and the valley cables. At the top, suspension cables run from the 46metre high masts to the center ring of the tent membrane. Stabilizing cables stretch from the center ring to the four corners of the tent units. The masts gather all the forces and lead them down to the foundations. (Berger 2005, 94–112)

The chosen fabric is PTFE coated fiberglass. A fabric material for the shading was chosen due to the qualities it has. Being light and foldable, fabric is economical to transport. It enables interesting design solutions. The chosen textile's high heat reflectance (70%) ensures that the fabric temperature remains sufficiently low. The fabric's translucency eliminates the need for artificial lighting during the daytime, thus eliminating the need for heat producing lighting. (Berger 2005, 94–112)

"Haj Terminal, ..., comes close to nature in its gentle way of taming the heat of the sun: a veritable forest in the desert". (Berger 2005, 109)

30b The structural system simplified.
(Berger 2004, 98)



5.12 Schlumberger Research Institute, Cambridge

Architect
Structural engineering
Structure
Fabric
Period

Anthony Hopkins, London
Anthony Hunt Associates, London
Tensile cablenet membrane
PTFE (Teflon) coated glassfibre
–1995

Schlumberger Cambridge Research Centre resides in the rural area of Cambridge, England. Also a commercial research building, this centre combines intellect with oil-drilling technology. The construction of this institute was completed in 1984. What is special about it compared to the other examples we have seen, is the combination of traditional architecture with that of tensile structures. This award winning construction is mentioned to be the first large-scale fabric membrane construction in Britain of its time. The construction can be considered analogous to suspension bridge structures.

The centre is a building for research and development. In it, a fabric membrane roof covers the social spaces and the oil-rigging test premises. The traditional, compressive structure surrounds the fabric part of the building and encloses laboratories and offices in two wings. The inside is designed to actively enable encounters and thus, create a space for inspiring atmosphere. (Tensinet 2010d)



31 Schlumberger Research Institute at night. The membrane fabric roof reflects the light of the interior, thus creating a luminous element in the landscape. The office wings can be seen lit on the ground level of the building. (www.hopkins.co.uk)

The membrane structure part of the roof is layered. The four groups of the tower-like double masts on both sides of the building suspend a steel cable netting. These aerial cables carry the roof membranes through point attachments with the membrane ridge cables. The structural parts together form the double curved surface required for the tensile membrane. In-between the three membrane parts, the prismatic steel trusses divide the roof into three. These trusses are glazed: the sky is seen in the centre of the building. See figure 31b for the structure principle. (Tensinet 2010d)

The fabric roof is made of PTFE (Teflon) coated fibreglass. It spans over a 24 metre wide space hosting the winter garden and the oil-rigging test station. The roof is not insulated. The fabric's light transmission value is 13%. Daylight enters the building through it. At night, the building is like a light reflecting series of diamonds in the landscape. See the night skyline in the figure 31a. (Hopkins Architects 2010)

"Schlumberger's soaring masts, and glowing, billowing fabric roof point into the Fenland sky, along with King's College Chapel. Its appearance on the skyline may be romantic, but this is essentially a practical building, with a subtle relationship between form and function (Hopkins Architects 2010)."

31b A detail principle of the Schlumberger Institute shows the combination of the compressive steel structure, the suspended aerial cable netting and the point attached, double curved membrane fabric structure. (Tensinet 2010d)

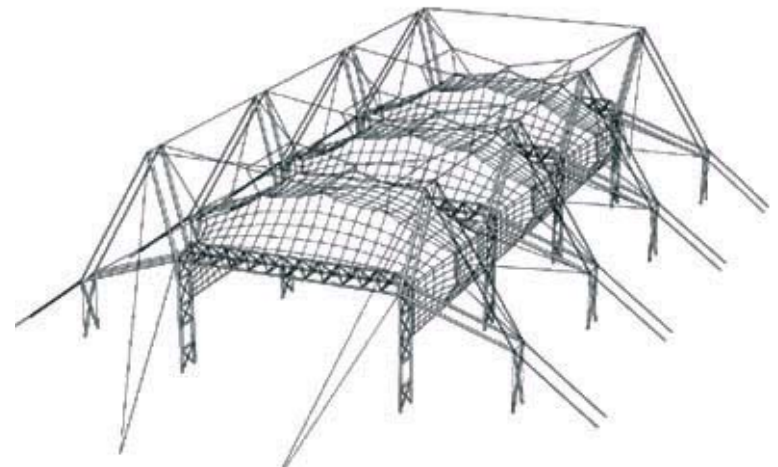

5.13 Curtain Wall House

Architect	Shigeru Ban, Tokyo
Structure of facade	Kinetic curtain wall in fabric
Fabric	-
Period	-1995

Japanese architect Shigeru Ban designed the Curtain Wall House in 1995 for a private customer in Tokyo. The building was constructed to reflect the lifestyle of the client; urban and open to public. The building finds itself in the corner of a dense city structure lifted up on columns. Its upper floors are clad with a curtain wall fabric that can either be closed or left open according to the dweller's will. A real curtain flowing in the city breeze replaces the traditional curtain wall of glass. It also translates the traditional Japanese kinetic paper, reed and bamboo screens and doors into a contemporary language. (Shigeru Ban Architects 2010)

In Shigeru Ban's design, fabric returns to private use in a single family house. The curtain wall hangs from the outer edge of the building's roof. The fabric creates an outer facade for the living floors of the building. In the winter, the hem the curtain may be attached to the floor to enclose the space and to ensure privacy and better insulation against the cold. (Designboom 2010; Shigeru Ban Architects 2010) The fabric clads the building like a cloth veils a man. Once the curtain is opened, the boundary between the public and the private vanishes. The house becomes a stage for the public to see. The clothes of the person occupying the space are now the textiles sheltering the private.

*"Mies invented the glass curtain wall, but I just used a curtain".
(Shigeru Ban in Designboom 2010)*



32 The Curtain Wall House in Tokyo. In the figure, the draping facade curtain clads the building like a dress. Shigeru Ban, 1995. (bakgård.blogspot.com 2008)

5.14 Millennium Dome (O₂)

Architect	Richard Rogers Partnership London
Project Director	Mike Davies
Structural Engineering	Buro Happold Consulting Engineers London
Structure	Mast supported, dome shaped cable network
Fabric	Self-cleaning PTFE coated glass fiber fabric
Area	100 000 m²
Period	1996–1999

Millennium Dome lies near the zero degree meridian on Greenwich Peninsula. It resides in a former site of gasworks on the shore of river Thames, in South East London. With its immense dimensions, the building is the largest dome shaped tensile fabric construction in the world. Completed in time for the celebration of the 21st century, it was originally built to host the Millennium Exhibition events. Nowadays it serves as an entertainment centre. (Rogers Stirk Harbour 2010)

The structure of the Millennium dome is a mast supported, dome shaped cablenet, see the picture below. The shape is based on a synclastic double curve, which means that the two sets of curves of the roof act in the same direction. A new generation of synclastic cablenet reinforced forms developed in the 1990's and eased the manufacture process of the cladding due to the simpler shapes required in patterning the fabric membrane. (MacDonald 2001, 90–91)

The building is a 50 meter high cap of an enormous sphere. Its diameter extends to 365 meters, one meter for each day in a year. The twelve supporting masts – a mast for each hour of the day or each month of the year - are reaching high to the sky like arms “out-stretched in cel-

33 The Millenium Dome in London.
The building is an enclosed structure
with a tensile cablenet roof covering.
The figure shows the building
illuminated in the evening.
(www.richardrogers.co.uk)



ibration" (Rogers Stirk Harbour + Partners 2010). These masts of 100 metres in height form an inner circle of 200 metres in diameter. Hanger cables supported by these twelve masts support the downward curving radial cables running from a central compression ring to the edge of the roof and to curved edge cables. The edge cables, in turn, anchor these beams to reinforced concrete anchoring points at the ground level. Inside, tie-down cables act together with the outside hanger cables to hold the radial cables in place. A double layered roof skin is stretched between the radial cables, which act as beams. These two, the roof and the cables, also participate in carrying of loads. (Habermann 2004, 226–231; MacDonald 2001, 90-91; Rogers Stirk Harbour 2010)

The roof skin is made of panels of self-cleaning PTFE (Teflon) coated glassfibre fabric. A roof light at the dome center lets daylight in: a 500m² and 12% translucent roof skin creates a glowing crown over the inside space. The construction has a double layered structure to keep the condensed water between the two layers. The roof surface is a downward curving series of facettes hanging from support points in pre-stressed radial cables and hanger cables. Stretched between the steel cables, the textile had to be carefully designed to achieve the required tension. The facettted solution made the patterning of the fabric easier, see the picture below. (Haberman 2004, 226–231; MacDonald 2001, 90-91; Rogers Stirk Harbour 2010)

"The ultimate inspiration for the Dome was a great sky, a cosmos under which all events take place – the radial lines and circles of the high-tensile roof structure recall the celestial reference grid of astronomical maps throughout the ages." (Rogers Stirk Harbour 2010)

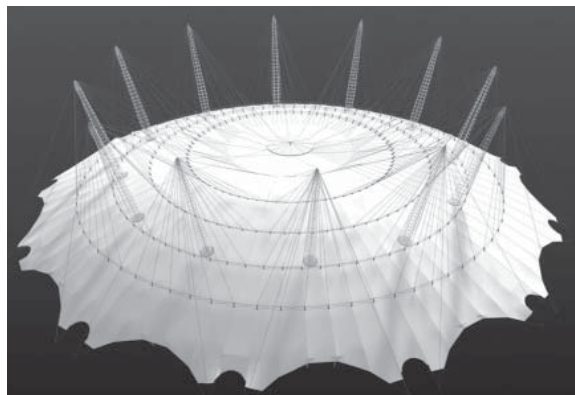

34 In the figure, we see the structural principle of the Millenium Dome roof by the contractor Birdair. (www.birdair.com/ Larson OBrien Advertising)

35 The Eden Project in St Austell. The figure from the interior of the biomes shows how the transparent roof fabric lets the light pass into the botanical garden. Nicholas Grimshaw Architects, 2001. (Stevekeiretsu 2001. CC-BY)



5.15 Eden Project, St. Austell

Architect
Structural Engineering
Structure
Fabric
Area
Period

Nicholas Grimshaw & Partners, London
Anthony Hunt and Associates
Enclosed light-weight geodesic dome
Transparent ETFE foil cushion structure
23 000 m²
1996–2001

The Eden project in St Austell, in Cornwall, England, is the world's largest greenhouse. Situated in a former mining area, a complex of multiple climatic shells nest in the contours of the surrounding land. Each of the eight interconnected geodesic domes contains a different biome with its own temperature, humidity and flora. The Eden project botanical garden as well as the building itself are a success: the place is one of the top three attractions in the country and has positively affected the local economy. (Grimshaw Architects 2001; Habermann 2004, 236–239; Tensinet 2010b)

The Eden project structure is constructed with prefabricated components; nodes, connecting rods and cushions. The geodesic domes consist of two layers of spherical steel nets, connected by compressive tetrahedral steel tubes. The inner net is composed of triangles and hexagons, the outer one mainly of hexagons with some pentagons and triangles fac-

ing the intersections of the domes. These domes are covered with dirt-resistant ETFE (polytetrafluoroethylene) cushions of layered foil. Pressure keeps the cushion forms stable. The thickness of a cushion can be up to two metres, their diameter varies from nine to eleven metres. The cushions are translucent, enabling the plants to grow naturally. Layers are thermally resistant, which minimizes the heating costs. (Habermann 2004c, 236–239)

American Buckminster Fuller is the person behind the development of the geodesic dome. He managed to patent the invention in 1954, although the idea was known already in the antiquity and was industrially realized first in 1922 in Germany. Eden project can be seen as a 21st century follower to Fuller's ideas of the 50's and 60's. (Kronenburg 1995, 40-51) Fuller's dome over Manhattan is now domes over Eden of England.

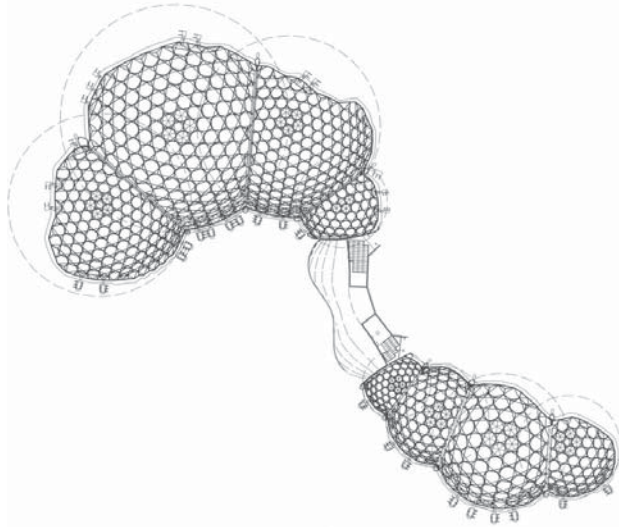

36 In the figure is the Eden Project roof projection of the eight biomes. The building rests in the landscape. (LeCuyer 2008, 67)

5.16 Spiky Pod

Architects
Structural Engineering
Structure
Fabric
Period

Alsop Architects, London
David Dexter Associates
Multi-conical hybrid compression and tension structure
PVC coated polyester
2000–2005

Spiky Pod is a seminar space created for the Queen Mary Hospital's Westfield Research Centre. It hovers up in the laboratory ceiling of the Blizzard laboratory building. Spiky Pod is an independent blob, an interior space inside a building, but so impressive that it is here included in the described projects among the exterior architecture examples. (Garcia 2006)

37 In the figure, Spiky Pod in Westfield Research Center, London. The three-dimensional form reaches out into the interior space of the laboratory building. (www.architen.com)



Spiky Pod is one of the four seminar pods of the research centre. Spiky pod is meant to house small and medium size seminar audiences, up to 30 people. It is tailor-made of elastic fabric and considered to be the world's most complex tensile structure. Inside, a platform with seminar rooms is surrounded by the wraparound skin. Will Alsop from the Alsop Architects describes the pod as "germ-like, slightly threatening just like the things that the medical researchers work with" (Will Alsop in Garcia 2006). (Garcia 2006; arcspace.com 2005)

The structure of the multi-conic Spiky combines tensile and compressive elements. Its origin is a sphere, from which pieces are pulled out. A skeleton structure works together with tension cables inside the external skin. The whole was erected by pushing and pulling techniques to make the structure taut and to resist loads. The PVC coated polyester fabric membrane was manufactured in one piece weighing a tonne. The chosen material is suitable for interior use. It has the elasticity and high strength needed for Spiky pod's structure. (Architen Landrill 2010; designbuild-network.com 2010; Garcia 2006)

Spiky Pod can be seen as "a nest like barriers between your environment and the outside world" (Will Alsop). Qualities related to textiles, such as comfort and cosiness, are experimented with in Alsop's spatial designs. They are characteristics absent from most current architecture. (Garcia 2006)

II TEXTILE

ARCHITEXTILE BASICS

Textile for Architecture

6 Architextiles

The use of textiles in construction is becoming increasingly popular. Technical textiles are replacing traditional textile materials as well as other materials, metals and construction materials (Adanur 2001, 319-360). In this study, we concentrate on technical textile fabrics suitable for architectonic purposes. The studied materials are meant to be seen as an integral part of architecture. Even further, the chosen textiles are suitable for exterior architecture and are used for both functional and aesthetic purposes. Also, the described textiles are broad textiles. Narrow textiles and ropes etc. are outlined from the study. To give an idea of further development possibilities in the field of textiles, a short introduction to intelligent (smart) materials is included.

Possible exceptions to the choice of the included materials will be explained as they follow. This is because the division between the traditional textile materials and other flexible engineering materials, like films, ceramics, composite materials, glass, extruded grids, fabrics, fibres and polymer membranes, is getting artificial. Common to the manufacturing and use of all the mentioned materials is the manipulation of fibres, fabrics and finishing and the understanding of the properties of flexible materials. (Byrne 2000, 1–23)

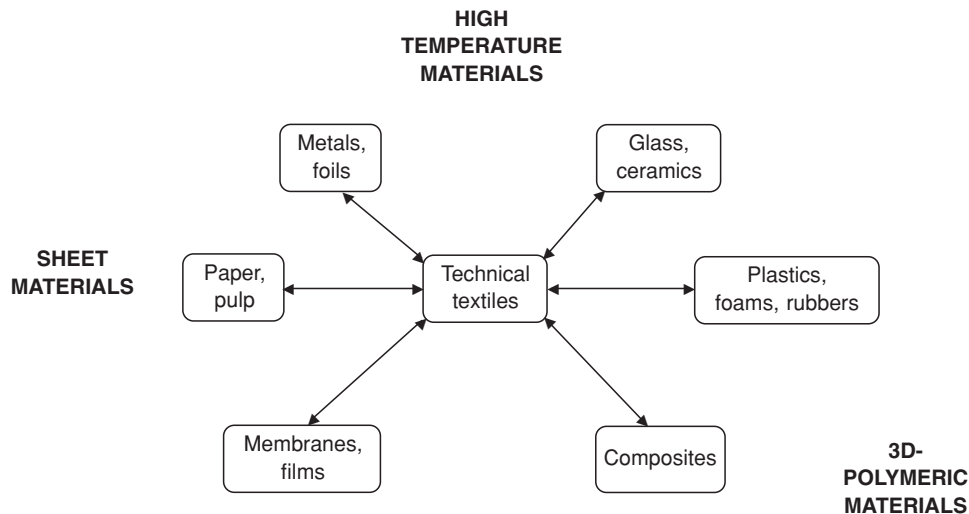

38 Chris Byrne discusses the boundaries of the field of technical textiles in the Handbook of Technical Textiles. In his introduction to the matter, he concludes that “technical textiles are likely to find their scope within a broader industry and market for flexible engineering materials”, see the figure on the left. (Byrne 2000, 4–5)

6.1 Textile, Fabric, Fibre

The word *“textile”* originates from the Latin terms *“textilis”* and *“texere”* (to weave) (*“textile”* 1996). The authoritative organization in textiles, the Textile Institute, located in Manchester, UK, defines *“textile”* in its Textile Institute’s Terms and Definitions Glossary as *“a general term applied to any manufacture from fibres, filaments or yarns characterised by flexibility, fineness and high ratio of length to thickness”* (Textile Institute’s Terms and Definitions Committee 1995). In another source, the word refers to *“...a material made mainly of natural or synthetic fibres. Modern textile products may be prepared from a number of combinations of fibres, yarns, films, sheets, foams, furs, or leather. They are found in apparel, household and commercial furnishings, vehicles, and industrial products. Materials made solely from plastic sheet or film, leather, fur, or metal are not usually considered to be textiles”* (Block 2010).

The term *“fabric”* includes a slightly wider selection of materials than *“textile”*. The word *“fabric”* comes from the Latin word *“fabrica”* and refers to textile stuff, but also to a construction or to a structure (*“fabric”* 1996). *“The term fabric may be defined as a thin, flexible material made of any combination of cloth, fiber, or polymer (film, sheet, or foams); fibre as a fine, rodlike object in which the length is greater than 100 times the diameter”* (Block 2010). *“Fibre”*, from *“fibra”* in Latin, was originally a thread-like body in animal or vegetable tissue (*“fibre”* 1996).

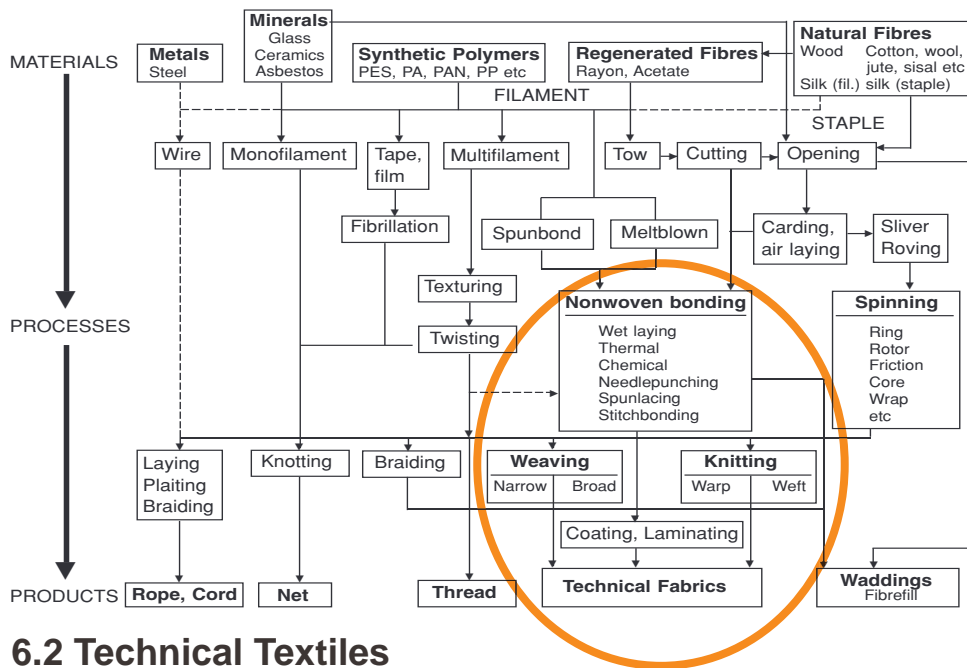

39 The materials, processes and products directly related to technical textiles. This study concentrates on woven, knitted and nonwoven technical textiles, see the figure on the left. (Byrne 2000, 4)

6.2 Technical Textiles

Technical textiles constitute one of the three main sectors in textile industry. The other two are household and clothing. The Textile Institute describes technical textiles in the following way: “textile materials and products manufactured primarily for their technical and performance properties rather than their aesthetic or decorative characteristics” (Textile Institute’s Terms and Definitions 1995). (Byrne 2000, 1–23)

Technical textiles are produced in industrial and industrializing countries and this involves several industry sectors and market segments. Techtextil in Frankfurt is the leading international fair for technical textiles. On their website, technical textiles are divided into categories according to the areas of application of the material: The twelve different categories determined by the end-use are Agrotech, Buildtech, Clothtech, Geotech, Hometech, Indutech, Medtech, Mobiltech, Oekotech, Packtech, Protech and Sporttech (techtexsil 2010). Based on the areas of expertise in the manufacturing process, different product groups divide technical textiles to even further categories such as research, technology, fibres and yarns, wovens and knitted fabrics, nonwovens, coated textiles, composites, bonding and surface techniques. (techtexsil 2010).

The main field of application of technical textiles in architecture is Buildtech, but also other fields of expertise may involve interesting fabrics to be considered, for example Agrotech and Geotech.

6.21 Coated and Laminated Textile Fabric Composites

Today, fabrics for architectonic purposes are textile fabric composites as we see from the fabrics used in the projects already described. These fabrics are mostly combinations of textile fabrics and polymer coatings. The Textile Institute defines composite fabrics: "...a material composed of two or more layers, at least one of which is a textile fabric and at least one of which is a substantially continuous polymeric layer. The layers are bonded closely together by means of an added adhesive or by the adhesive properties of one or more of the component layers" and "a textile fabric on which there has been formed in situ, on one or both surfaces, a layer or layers of adherent coating material" (McIntyre et. al 1995 according to Fung 2002, 1). (Fung 2002, 1–23) These two definitions include coated and laminated fabrics.

Textiles and plastics form composites. The base-fabric modifying properties are an important factor in coated and laminates textiles. The polymer layer affects mainly the chemical properties. The fabric in composite structures determines mostly physical properties. The layers together determine the properties needed and the combination is always carefully designed. (Fung 2002, 1–23)

In addition to the common polymer coatings or laminates, there are special chemicals that can be added to the polymer or as topcoats to achieve various special properties when combined with the fabric. There are for example photo-luminescent chemicals, colour changing dyes and UV absorbing agents just to name a few. (Fung 2002, 1–23) These new materials add to the vast variety of properties that can be achieved with composite fabric structures. These possibilities could also bring more substance and functionality to architecture.

6.3 Intelligent (Smart) Textiles and Materials

The use of textile offers a wide range of new possibilities for architecture. Intelligent textiles and fabrics are among the most exciting recent developments of textile industry. Such materials add a whole new dimension to the spectrum of ideas available for the architect opting for textile and fabric based solutions.

The concept of intelligent textiles became commonly known in the textile industry in the 1990's. Innovations in the field of functional and intelligent (smart) textiles are continuously developed and commercial applications are actively created. Intelligent textiles and fabrics are fibres and materials possessing functional properties and responding to

their environment. These textiles are the future generation of technical and high-performance textiles. Intelligent textiles are divided into three subgroups which are passive, active and very smart (intelligent) textiles. The difference between the passive and active smart textiles is that the passive ones sense their environment, whereas the active smart textiles also react to the sensed stimuli. Even further, the very smart textiles, or the intelligent textiles, have the ability to sense, react and adapt their behaviour according to their environment. (Tao 2001, 1–6)

Intelligent (smart) textiles and other intelligent materials have features that are common to all of them. The passive smart materials act as sensors. The active smart materials sense and react to stimuli. They are sensors and actuators. The intelligent materials act as sensors, actuators and processors. They can sense, react and adapt to their environment. They may include a power source, data processing and transmission devices, actuators and sensors in their structure. The impulses that smart materials sense include chemical reactions, humidity, electricity, force, magnetism, mechanics, light, pressure, sound and temperature. The reaction to stimuli may result in changes in the materials' conductivity, electrical properties, form, optical features, colour and light related properties and structure. Intelligent textiles have smart factors incorporated into the fibres, yarns, fabrics or their coatings or laminated layers. These properties can also be printed, sewn or embroidered onto the fabric. (Clevortex 2005)

6.31 Chromic Materials

Chromic materials react by changing, erasing or radiating colour, or altering other physical properties. They are also called chameleon materials, which describes their behaviour well. Chromic materials have been studied since before the 1900's. The most used chromic materials in textile applications are the photochromic and the thermochromic materials. Below is a list of different chromic materials and the stimuli they react to. (Talvenmaa 2006, 193–205)

CHROMIC MATERIAL

electrochromic
 carsolchromic
 piezochromic
 photochromic
 solvatochromic/hydrochromic
 thermochromic

STIMULUS

electricity
 electron beam
 pressure
 light
 liquid
 temperature

Photochromic materials change their colour in reaction to the change of intensity of light. The change is reversible. Photochromic compounds are organic or inorganic. The inorganic materials base their technology on silver particles the organic materials are often combined with polymer matrices. The challenge with chromic materials concerning applications in construction has been their short lifetime. (Ritter 2007, 73–80; Talvenmaa 2006, 193–205)

Thermochromic materials change colour in reaction to temperature changes. The change is a reversible change, although products where the change is irreversible exist also. Thermochromic materials have been studied since the 1970's. Different related mechanisms and different materials exist: organic and inorganic compounds, polymers and sol-gels. The often dramatic changes can be achieved in textiles mostly by altering the crystal structure or rearranging the molecules of organic thermochromic compounds. (Ritter 2007, 80–88; Talvenmaa 2006, 193–205)



40 Medialization of architecture, or mediatecture, can be seen in the application of GDK's metal mesh fabric Mediamesh®. It takes advantage of light emitting diodes, LEDs, in its woven structure. A screen veils the building into a constantly changing, narrative image. A server and power supply are attached to the screen. (GDK 2010)

6.32 Conductive Materials

Electrically conductive textiles are called **electrotextiles**. Conductive materials are able to carry and conduct electric energy. For example plastics, metals like aluminium, copper and steel, or carbon are used. Highly conductive, normal and semi-conductive materials and insulators exist. Textile and fabric-based electrical circuits enable the material to integrate for example power generating electronic devices into its structure. (Harlin & Ferenets 2006, 217–238; Ghosh, Dhawan & Muth 2006, 239–282)

Optical fibres, for example glass fibres, are able to carry signals as pulses of light without repeaters for long distances. The information carried can be computer data for example. Also sound waves can be transmitted. In architecture, it is rather interesting to illuminate the environment and buildings with the help of optic fibres. Another solution is integrating LED lights into fabric structure, see the figure 40. (Clevortex 2005)

6.33 Electricity Generating Materials

Electricity generating materials generate electric energy in response to chemical, light, temperature and pressure changes. For example **photo-voltaic** cells are capable of producing electric energy from solar radiation, see the figure 41. Depending on the cell types, different conversion efficiencies are met. The numbers vary between ~30% and ~70%. The resulting current depends on the number of photons absorbed. Impor-

tant from the point of view of textiles are flexible solar cells, usually integrated into plastic films. Printable cells exist also. Textiles work as substrates to the cells. This enables for example three-dimensional energy generating fabric surface enclosures that can be used as building envelopes. For example the UV-resistant fibre PET (polyethylene terephthalate), which is often used in architectural fabric constructions, is suitable for this purpose. Conductive fibres are interesting since they can act as conductors for the generated current. Otherwise, a conducting layer is needed. (Mather & Wilson 2006, 206–216)

6.34 Phase Change Materials (PCMs)

The development of phase change material technology begun with a 1970's NASA research programme. **Phase change textiles** include microcapsules, which store and release energy through the phase change of materials. Here phase change means the change from a liquid to a solid state or vice versa. PCMs are usually coated onto textile surfaces. These materials may be used in roof coverings, canopies and curtains to store solar thermal energy or to help in insulation and air conditioning; this stabilizes the difference between day and night temperatures. (Bendkowska 2006, 34–62; Mäkinen 2006, 19–33)

A curiosity: Phase change materials are already used in textile applications in buildings. A recent application of a thermo-regulating fabric material is Tensotherm™ with Nanogel® by the American company Birdair. The fabric includes a sandwiched nanogel layer in its structure. The layer prevents the loss of heat and the gaining of solar heat by the material. The fabric is constructed of PTFE fibreglass and the nanogel layer is added to the structure. The thermal regulating property of this material is based on nanogel's phase changing properties, thus making use of smart material technology. In addition to this, a TiO₂ (titanium dioxide) coating makes the fabric resistant to soiling. (Birdair 2010a)

6.35 Shape Memory Materials (SMMs)

Shape memory materials react to external stimuli by changing their shape. Once the stimuli are no longer experienced, the materials restore their original shape. The external stimulus may be related to electric and magnetic fields, pH-value, temperature, stress or UV-light. The reaction maybe related to properties concerning for example friction, natural frequency, position, shape, stiffness, strain or water vapour penetration. For example ceramics (SMC), metal alloys (SMA) and polymers (SMP) can act as shape memory materials. This technology was developed starting in the 1930's. (Honkala 2006, 83–103, Hu et. al 2006, 105–123)



41 In the figure, the photovoltaic solar panels are integrated onto a vinyl coated polyester fabric. PowerMod by American company FTLsolar generates solar power, stores and distributes it. Each PowerMod panel produces 1200 Watts: total electrical system efficiency is 75%: $1200W * 5.0hours/day * 0,75 = 4.5kWh$ per day. Several panels attached provide more energy. Energy can be used for example for using laptops, mobile phones, refrigerators, radios etc.. (FTLsolar 2010)

7 Fabric Manufacturing

7.1 Fibres

Technical textile fabrics are made of fibres of a natural or man-made origin. Technical properties of fibres have been understood for quite long in the history, but their professional and commercial use is considered to have its origins in the 20th century. Conventional natural and man-made fibres are the most common fibres in technical textile construction. (Miraftab 2002, 24–41). Such fibres are listed in the appendices 1 and 2.

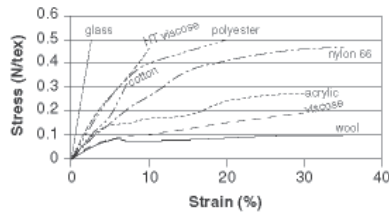

42 The figure shows the resistance to deformation of a selection of fibres.

This is described here by showing stress as a function of strain: Strain is the percentage of elongation when a fibre is stretched. Stress describes the tenacity required for the stretch (Newton/tex (tex=gram/kilometre)). (Miraftab 2000, 29)

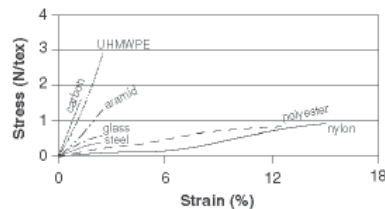

43 The high performance fibres show a higher resistance to deformation compared with that of conventional fibres. The curve for glass, shown in both figures, can be used for comparison. (Miraftab 2000, 34)

The standard conventional natural fibres used in all technical textile production are cotton and wool, and in smaller volumes, silk, flax, hemp, jute and ramie to name a few. (Miraftab 2002, 24–41) The most common of these in architecture is cotton.

Conventional man-made fibres were developed starting in the end of the 19th century and the first commercial applications were available in the beginning of the 20th century. The first one of them were the regenerated fibres, the most common of them viscose and acetate fibres. The second generation fibres, the synthetic fibres, based on coal or oil, were developed starting in the first half of the 20th century. The first one of these was nylon (polyamide PA), which became commercially available in 1939, and which was produced by the American company DuPont. Polyester (polyethylene terephthalate PET) followed in 1951, again by DuPont by the name of Dacron. Later developed synthetics included for example polyacrylics, modacrylics, polyolefin fibres and elastan. (Miraftab 2002, 24–41) The most used conventional man-made fibre in textile architecture is polyester.

The third generation fibres are the high-performance fibres. Their development started in the middle of the 20th century. These fibres include organic fibres such as para-aramids (like PPTA, polyphenylene terephthalamide (Kevlar) 1971-), meta-aramids and high-performance polyethylene (like PTFE, polytetrafluoroethylene (Teflon)) and inorganic fibres; carbon, glass and ceramic fibres. High-performance fibre characteristics include properties like high strength, high modulus and good chemical and thermal resistance. Some inorganic fibres are able to perform in extremely high temperatures. A number of ultra-fine microfibrils exist also and different novel fibres are constantly developed. The use of high-performance fibres for architectural purposes is becoming more common. (Miraftab 2002, 24–41)

7.2 Textile and Fabric Manufacture

7.21 Woven Structures and Weaving

Weaving is the most common technique to produce textiles. Weaving machines are either single or multiphase machines operating either one yarn by one, or by inserting several picks simultaneously. Generally, woven fabrics are produced with two sets of yarns, which are interlaced orthogonally, but thri- and tetra-axial fabrics exist also.

The modern weaving industry developed strongly after World War II, although the principles of weaving have remained unchanged since the first attempts to interlace nature's materials in prehistory. First evidence of developed, warp-weighted looms to have survived, is from 6000 BC in Hungary, although earlier ones surely have existed. Wide-loom technique became more common in 4000 BC. However, no sooner than in the 1800th century, did significant developments in the weaving technique occur. In 1830's, England had already some 100 000 shuttle looms in operation. (Adanur 2001, 1–7, 19–34; Schoeser 2003; Sondhelm 2000, 62–94)

The development continued through the 20th century. The second generation of weaving machines were the single phase machines and they were developed during that century. The multiphase machines developed principally after World War II. The rapid developments in technology at the end of the 20th century and in the beginning of the 21st century have reduced the production costs of weaving. The production rate has become faster and faster. The industry became capital intensive due to the automatisaton, and thus, labour needed in the manufacturing processes diminished. (Adanur 2001, 1–7, 19–34; Schoeser 2003; Sondheim 2000, 62–94)

Woven fabrics can obtain higher strengths and stabilities than any other structures in textile manufacture. The two different yarn directions in woven fabrics are the weave and the weft. Weaves are the ones running along the length of the fabric and forming the warp. The weft crosses the warp from one side to the other. The simplest woven structure is the plain weave, which has the weft yarn lowered or lifted each time it crosses a weave. In thriaxial structures, two sets of warp yarns are interlaced with the weave, generally at 60°, whereas tetra-axial structures are achieved with four sets of yarns, interlaced at 45°. (Adanur 2001, 19–34; Sondheim 4; 62–94)

Fabrics are specified according to their properties. Among the most important factors to woven fabrics are the width of the cloth, the number

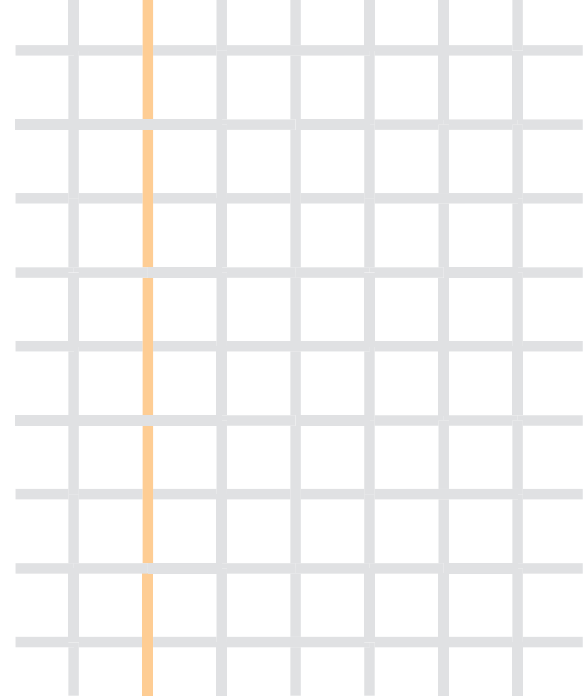

44 Woven structures are the most used structures in textile architecture. In German company GDK's products, this polyvalent structure is introduced into metal mesh fabrics. GDK has several different structures in their selection. These meshes are used for example in suspended screens and sun shades in exterior architecture. In the figure above, we can see one of the products, called Herringbone. (GDK 2010)

of threads per centimetre (per warp and weft), the linear density (grams per kilometre (tex)), the fabric area density (grams per square metre) the type of the yarn(s) used, the structure of the weave, the cover factors of the cloth, the thickness of the cloth and the properties resulting in from the finishing process. (Sondheim 4; 62–94)

7.22 Knitted Structures and Knitting

Knitting is the second most used technique in textile production after weaving. It is less used in technical textile applications compared to the use of woven and nonwoven fabrics. In knitting, one or several yarns are interlooped to form a continuous structure. Knitting is the most common mechanical interlooping technique used to manufacture fabric. (Spencer 2001, xxiii, 1-6, 370–379)

Today, knitting has developed into a modern technology producing a wide range of materials and products for domestic and industrial use from the finest lace to the finished garment products and to the most durable, knitted metal wire structures. There are two different knitting techniques, the warp and the weft knitting. A variety of different machine types are producing flat, circular, and shaped structures. Warp knitted fabrics and some weft knitted fabrics are used in technical textile applications. (Spencer 2001, xxiii, 2, 370–379)

Knitting developed from prehistoric interlooping techniques binding material into nets and other structures for various purposes. First techniques were based on the use of fingers. Hand pin knitting followed. The first examples can be found in the 14th century Italian paintings. The first knitted objects were small garments, caps and stockings. From Italy, the techniques spread over to the rest of Europe. By the 16th century, knitting was used in order to produce luxurious silks and wools for the Western world. (Schoeser 2003, 90; Spencer 2001 7–15).

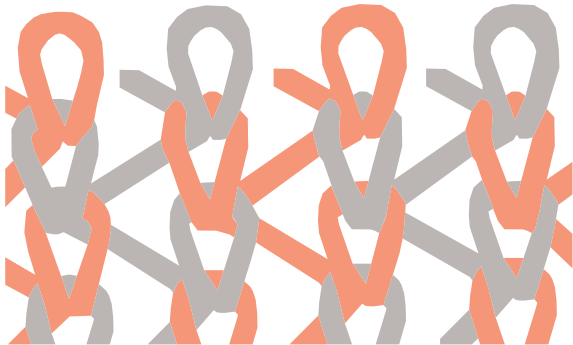

No sooner than in the 18th century was knitting technique so developed that machine produced pairs of socks were considered comparable to hand-made ones. The first invention developing knitting for industrial applications was the English reverend William Lee's stocking hand frame. In the year 1589 it was 200 years ahead of its time. Lee's solution was the precursor of all weft and warp knitting machines of the modern world's knitting industry. Warp knitting developed starting in the 18th century, first by Crane and Porter's ideas in 1769 in England. From England, the knowledge spread over to European cities as well. The techniques were further developed mostly in England during the following centuries and all the way to the 21st century. Knitting benefited from the

development of synthetic fibres around the 1940's and since then, these industries have been closely related. The golden age of knitting was in the 60's and 70's, when fashion found synthetic fibres and the rapid way of producing material for clothing by knitting. The development continues today and the technique offers possibilities for all sectors of textile industry. (Schoeser 2003; Spencer 2001, 7–15).

Compared to other production techniques, knitting has an advantage, which is its versatility and rapidity. Possible structures are endless and knitted constructions can easily be designed to meet exact end-use requirements: Flat structures, shapes, meshes and nets or three dimensional products can be achieved. One and multi-axial constructions and composite structures can be produced. Often, waste of material can be avoided by the choice of a suitable knitting technique. The yarn encounters less stress than in weaving. Thus delicate fibres, such as aramid, carbon and glass can be used. Knitting can also be combined with for example nonwoven technology to form composite structures. (Spencer 2001, xxiii, 2, 370–379)

Knitted textiles are chosen especially when for example drapability, flexibility, knitting to shape, mouldability, open net structures or low costs are required. Today, a multitude of structures can be produced and exact requirements can be met. Possibilities include for example changing the sizes of the loops, taking advantage of the distortion of the loops under tension, altering the number of loops or their sizes along the width and depth of the fabric, creating special surface structures, knitting to shape, changing the type or material of yarns etc.. (Spencer 2001, xxiii, 2, 370–379)

7.23 Nonwoven Structures and Nonwovens

Nonwoven fabric is a flat structure in which the chosen material is bonded chemically, mechanically or thermally. The main difference with the traditional textile techniques is that there is no need to convert the chosen material into yarn, nor is it woven or knitted to form a binding structure. The production of nonwovens involves three stages: web (or batt) forming, web bonding and/or manipulation and finishing. These operations can be performed one after another – separately or overlapping each other. (INDA 1997/2006; EDANA 2009c)

Nonwoven industry has its origins in the 1950's Eastern Europe. Once regarded as a cheap substitute for traditional textile techniques such as weaving and knitting, this industry has grown from leather -, paper -, polymer - and textile processing industries to be the highly profitable



45 Knitted architectural fabrics are still rare to find. The Australian company Polyfab manufactures knitted sun shade membrane fabrics. In the picture is the company's Comshade, made of knitted fabric and used as a sun shade. It is made of High Density Polyethylene and combines Ultra Violet (UV) stabilisers and colour additives. The fabric is treated to block out UVA and UVB radiation. (Polyfab 2010)



and sophisticated industry of today. (Wilson 2007) Although a relatively young industry, nonwoven techniques date back thousands of years. Felting was used as a technique already in prehistoric times. It is suggested that wool and possibly felt was first used among the sheep herding nomads in areas across Ukraine and Siberia for clothing and tents. The related findings are scarce. The earliest material discoveries are from 6500-6000 BC in Turkey's Catal Hüyük. (Schoeser 2003, 24–25)

Nonwoven technology is subcategorised by the web forming phase. The technique to form a web can be a drylaid technique that derives its origins from textile industry; a wetlaid technique with roots in paper making or a spunlaid or polymer-laid techniques that have their machinery developed for polymer extrusion. The following processes of bonding can be chemical, mechanical or thermal and a combination of processes can be used. (Wilson 2007) Each decision in the manufacturing processes affects the nonwovens produced. In web formation, the manufacture width and weight are chosen. The composition of fibre orientations affects the fabric's tensile strength. In the web bonding stage, density, flexibility, porosity, softness and strength are determined by the degree of bonding. (Wilson 2007)

46 Nonwoven fabrics are often employed in geo-construction as geotextiles for drainage, filtration, reinforcement, separation etc.. They are not often a visible part of architecture, but they take part in the construction as an integral part of the structure. An interesting phenomenon is, for example, needlepunched nonwovens for green roof structures. In the picture is a semi-intensive (soil layer of only 10–15cm thick) green roof in Malmö, Sweden. (Greenroof 2010)



The third stage in manufacturing nonwovens is the finishing phase. Several properties can be achieved by the finishing treatments. The end-use application determines the processes chosen. Finishing can modify or add to the existing properties of the nonwoven fabric. The finishing methods are traditionally divided into dry and wet finishing. (Ahmed 2007) Chemical substances can be used before and after binding, whereas mechanical finishing processes are applied after the web (batt) is reinforced in the binding stage. After finishing, the nonwoven fabric is rolled and can be further converted closer to its final form. (EDANA 2009d)

Nonwovens are versatile. Used alone or combined with other materials, nonwovens can be designed to meet specific end-use requirements along with achieving reasonable cost-effectiveness and product life ratios. Specific demands are met by the choice of raw materials, production methods and by the selection of finishing methods. Limited life, single use and durable nonwoven structures are made, which is seen in the broad variety of industry branches and end-use applications using nonwovens. The most used materials are polypropylene and polyester. It is good to note that not all nonwovens are considered textiles, although their nature is often textile-like. (Edana 2009be; Wilson 2007)

The ISO standard 9092 and CEN EN 29092 from the year 1988 defines nonwovens. The evolution of the industry has led to the situation where experts in ISO are updating these standards. The proposal to the International Standardization Organization by EDANA (European Disposables and Non wovens Association) and INDA (North American Association of the Non woven Fabrics Industry) is as follows:

"A nonwoven is a sheet of fibres, continuous filaments, or chopped yarns of any nature or origin, that have been formed into a web by any means, and bonded together by any means, with the exception of weaving or knitting. Felts obtained by wet milling are not non wovens.

Wet laid webs are nonwovens provided they contain a minimum of 50% of man-made fibres or other fibres of non vegetable origin with a length to diameter ratio equals or superior to 300, or a minimum of 30% of man-made fibres with a length to diameter ratio equals or superior to 600, and a maximum apparent density of 0.40 g/cm³. Composite structures are considered nonwovens provided their mass is constituted of at least 50% of non wovens as per to the above definitions, or if the non wovens component plays a prevalent role." (EDANA 2009b)

7.3 Fabric Finishing, Coating and Lamination

The purpose of finishing is to improve the fabric's functionality and its esthetic values. Four main subgroups of finishing exist. They are the mechanical finishing processes, heat setting processes, chemical finishing processes and finishing processes related to coating processes. Fabric finishing and coating processes can be very similar to each other. Coating processes differ from finishing processes such that a coating process closes the holes of a fabric to some degree, whereas finishing forms a cover only on the yarns. Almost all fabrics for architectural purposes are coated. (Hall 2000, 153–172)

Coating is done by applying a direct thermoplastic polymer spreading on the fabric. Here, the fabric acts as the substrate for the coating. After the spreading, the coating is dried or cured into a deposit layer on top of the fabric. Coating materials worth mentioning are for example PVC (polyvinyl chloride), PVCD (polyvinylidene chloride), PTFE (polytetrafluoroethylene), natural and synthetic rubbers, polychloroprene (neoprene), chlorosulphonated polyethylene (Hypalon), silicone rubbers and polyurethanes. (Hall 2000, 173–186)

Polymer materials are applied to fabrics by a separate lamination process. In lamination processes, several techniques and adhesives are used

to attach the polymer to the fabric. The used adhesives are solvent or water-based films, granules, jellies, powders and webs. Machinery and manufacturing methods are chosen according the substrate material; flat and uniform or stretchy and structurally uneven. Achieving the desired fabric properties in the combined structures is challenging. These properties are similar to coated fabrics' properties. Lamination shortens the time of production, lowers the production costs and ensures even quality. It can also prevent the need of sewing when the final product is prepared for its end-use purpose. (Hall 2000, 173–186; Fung 2002, 1-23, 83–66)

The substrate fabric affects the physical properties, whereas coating or lamination affects the chemical properties of the fabric. In addition to the properties of the substrate and the polymer layer, many of the properties of the finished fabric result from the combination of the layers. The layers are carefully designed to act together for the desired purposes. (Fung 2002, 1–23) Ian Holme summarizes the effects of coating and lamination in the book *Coated and Laminated Textiles*:

“Coatings or film lamination can be used as:

- a) coverings or as a barrier for protection, separation or containment
- b) for appearance modification for decorative or functional purposes
- c) improving dimensional stability, controlling stretch, preventing edges from fraying or curling
- d) for control of porosity, e.g. for filtration
- e) as a matrix for holding some functional material, chemical, pigment or other agent
- f) as a processing aid, for example in 'in situ' moulding, vacuum technique or thermomoulding
- g) combining the specialist properties of polymers with the flexibility, strength, drapeability and covering power of a fabric.” (Holme 2000, 19)

7.4 Coloration of Fabrics

The coloration of fabric results in a uniform or patterned colour design. This enables versatile possibilities for decoration in architecture. The techniques to achieve coloured effects are dyeing and printing. Several techniques exist with water-soluble or pigment colorants. Dyeing can be done in various stages of the fabric manufacturing process. Printing is mostly done onto the manufactured fabric. Colouring affects not only the aesthetic properties of the fabric, but it may also take part in the heat and light related properties. Printing is often the solution to achieve a desired colour, since many of the technical textile fibres are difficult to dye. (Holme 2000, 187–222)

8 Choosing the Fabric

Textile is the fifth material in architecture along timber, stone, metal and glass. For architectural purposes, textile and fabric must be strong enough for the desired spatial span. It must carry external loads from wind and snow. In exterior use, it has to be resistant to weather. It needs to fulfill requirements concerning cleaning, daylight, fire and acoustic issues to name a few. It needs to be durable enough for its purpose.

Choosing the appropriate fabric material for the desired architectural purpose should be considered at the early stages of the process. Architectural, technical and economical factors participate in the decision process. Multiple properties have to be considered. This involves several different fields of expertise, and the decisions should be made by interdisciplinary groups. (Pudentz 2004, 48–65) The most important such properties are discussed next. These properties are discussed mostly by considering the three most common fabric membrane materials. These are PVC coated polyester, PTFE coated fibreglass and ETFE foil.

8.1 The Essential Fabric Properties

8.11 Tensile Strength and Tear Strength

A fabric must have a required strength to span between its supports, carry wind and snow loads and enable the maintenance of the structure. For example it may be required that it is strong enough to carry people walking on it. The necessary figures depend on the form finding process, and through it, the calculations concerning the fabric membrane prestressing and patterning. Tensile strength is described in the units N/5cm. The figures vary between 0.2 and 10 kN/5cm. The spans achieved depend upon the fabric's manufacturing measures, the methods of joining strips of fabric together and the strength of the seams etc.. (Pudentz 2004, 48–65)

8.12 Resistance to Buckling and Mechanical Wear

The manufacture, transport, mounting and maintenance of a piece of fabric requires it to be somewhat resistant to buckling. Movable or kinetic structures have specific demands and the fabric material in them has to have good buckling resistance. Here, the best materials are PTFE fabrics and PVC coated polyesters. Glassfibre fabrics are not suitable for kinetic membrane construction. (Pudentz 2004, 48–65)

8.13 Weight

Fabric weight is low compared to other construction materials, which makes fabrics especially suitable for large span structures. Weights vary between 0,2kg/m² to 1,5kg/m². (Pudentz 2004, 48–65)

8.14 Durability

Chemical resistances of a piece of fabric material, its resistance to UV light and its tolerance of mechanical wear and folding in movable and kinetic structures affects the life span of the fabric. The fabrics used in exterior architecture today are resistant to UV radiation. For example PVC coated polyester is estimated to maintain its properties for 15 to 25 years. As it is resistant to folding, it is often used in movable and temporary constructions. PTFE coated glassfibre fabrics and ETFE foils seem to last for more than 25 years and are often chosen for sedentary purposes. (Pudentz 2004, 48–65)

8.15 Weather and Temperature

The fabrics for exterior architecture are designed to be resistant to weather; rain, wind and UV radiation. The temperature ranges can be wide. Generally, assembling fabric based structures is not encouraged in circumstances under 5°C. PVC coated polyester is not able to perform in constant sub-zero climates. (Pudentz 2004, 48–65)

8.16 Resistance to Chemicals

The commonly used fabrics have good to very good resistance to chemicals, a property required in challenging environments. (Pudentz 2004)

8.17 Properties Concerning Light

Light absorption, reflection and transmission are of interest when choosing the right material for architectural purposes. These factors can be used to help lighting and shading of the space enclosed. They may affect the thermal properties of the interior. Indirect light, illumination and energy related questions may be considered in relation to these properties. These properties are described by using percentages. For example transparent ETFE foil may reach a 95% transmission rate, PTFE coated fibreglass can reflect 70% of light. The colour chosen can affect the absorption rates up to 25%. (Pudentz 2004, 48–65)

47 The diamond-like appearance of the wall house's fabric is achieved by the folding fabric surface and by changing its properties; sometimes reflective, sometimes translucent. (FAR frohn&rohas 2010/ Cristobal Palma)



A curiosity: wall house, Santiago, Chile (2004–2007)

The exterior wall of the wall house by architects Frohn&Rohas, in Chile, is made of fabric, see figure 47. The walls of the building are released into layers, where the outermost one is a loose-fitted membrane fabric. The fabric was made locally and can be seen as a low-tech solution. (FAR frohn&rohas 2010)

8.18 Colour

Fabrics may be coloured or printed onto in order to achieve narrative properties or to participate in regulating lighting and thermal properties of structures. PVC coated polyester is the most versatile material in relation to colouring and has the largest number of options to choose from. ETFE foils can be printed and coloured. PTFE and silicone coated fabrics cannot be printed onto, but they are available in a variety of colours. Colours are used to achieve strong visual effects, but they also affect the thermal properties of structures. (Pudentz 2004, 48–65)

8.19 Acoustic and Thermal Properties

Fabrics have weak acoustic insulation properties. Putting additional layers onto a multilayered structure enables challenging requirements to be met. Absorption values can be enhanced by using perforated foil materials under the fabric layers. Also thermal insulation is a challenge for fabric architecture. Thermal insulation can also be dealt with multilayered structures with air-cavities between them. (Pudentz 2004, 48–65)

8.20 Properties Related to Fire

Being light, fabrics have a low fire load. This is an advantage. The standard EN 13501-1:2007 has a Finnish national standard status. It includes “Fire classification of construction products and building elements. Part 1: Classification using data from reaction to fire tests” (SFS-EN 13501-1). Architectural fabric materials are certified by their manufacturers. Necessary requirements must be met, see the figure on page 82. Possible classes according to EN 13501 are classes A1, A2, B and C. Smoke production class should be s1 or s2. Fire behaviour regarding droplets and other parts must be d1 or d2.

8.21 Cleaning and Maintenance Properties

Resistance towards soiling is parallel to the properties concerning maintenance issues. A structure can be designed so that it minimises the possible effects of environmental factors and the effects of the chemical materials used for cleaning purposes. Superior properties are achieved with coatings of PTFE and PVDF (topcoat for PVC) and ETFE foils. (Pudentz 2004, 48–65)

A curiosity: New properties and materials are continuously developed. A recent application facilitating the cleaning properties of fabric material is TiO_2 (titanium dioxide) coated PTFE fibreglass by Birdair. It is a self-cleaning fabric that breaks down organic materials through an oxidation reaction. Rain washes the remnants away. (Birdair 2010b)



48-49 St. John's Shopping Centre, a retail building in Liverpool, was clad in printed PVC fabric to promote Liverpool as the City of Culture in 2008. The three-dimensional form required challenging image correction for the printing and careful calculations for patterning of the sculpted fabric panels. (Architen Landrell 2008)

8.2 Cost-Related Issues

In membrane structures, the cost of the fabric alone doesn't provide an adequate understanding of the construction costs as a whole. It is the whole construction that has to be considered: the primary structure, the attachments and the membrane and all the specialist work involved in the process. These properties all add to the decision making. The estimates are advised to be a part of the design process and, the related issues should be considered by an interdisciplinary team. (Pudentz 2004, 48–65)

8.3 Ecological Issues

Fabric structures enable the minimum use of resources. The low weight of fabrics reduces the logistic costs. ETFE foils can be fully recycled and PVC coated polyester may be partially recycled. Long life-span PTFE fabrics have a buy-back guarantee and their recycling properties are continuously developed. New recycling methods are being developed. (Pudentz 2004, 48–65)

A curiosity: In 2009, the first fully recyclable architectural fabric material was launched by the North American company Taio Kogyo. The material, **Kenafine**, is made of the bast fibre of the kenaf plant. This plant has one of the highest rates of carbon dioxide absorption compared to other plants. At the end of its life as a membrane, this fabric material can be recycled into paper products. (Textile World 2009)

8.4 Fabric Quality and Assembly

The fabric manufacturer carries out the necessary tests concerning the demands of the end-use application. This includes the physical and mechanical properties of the fabric, the visual properties and the adhesion achieved by the chosen methods of joining the fabric pieces together. The fabric is patterned and cut, jointed by sewing, welding or by using adhesives. Necessary reinforcements are added at early stages. Quality control, packaging and transportation follow before the product is ready for the assembly on spot. All these phases should be carefully thought about to ensure the necessary quality desired. (Pudentz 2004, 48–65)

8.5 Common Fabrics for Architecture

Architectural fabrics are mostly coated fabrics, meshes, sheets or films. Some of the common uncoated fabrics are cotton and polyester, metal and fluoropolymer fabrics. Cotton and polyester mixes are impregnated against weathering and used mostly in small to medium structures. Metal fabrics are chosen for facades, protection or sun shading purposes. Fluoropolymers like PTFE is suitable for kinetic structures. (Moritz 2000)

Most of the architectural fabrics are coated or laminated fabrics with a closed or an open textile matrix base. The most common materials are PVC coated polyester and PTFE coated fibreglass. Silicone coated fibreglass is a recent newcomer. Also popular materials are coated fluoropolymer fabrics (PTFE, ETFE, PVDF etc.), PVC coated glassfibres and aramide fabrics. ETFE sheeting replaces coated fabrics more often now. (Moritz 2000)

8.51 PVC Coated Polyester

PVC coated polyester is one of the most common architectural fabrics. Its advantages are its tensile and tear strength and high elasticity. The material is considered inexpensive with a life-span of approximately 15-20 years. It is suitable for example for long spans and temporary structures. (Moritz 2000)

8.52 PTFE Coated Fibreglass

The durable PTFE coated fibreglass is often an alternative to PVC coated polyester. Its tensile strength is very similar to those of PVC coated polyester fabrics. However, it is expensive and often chosen for more valued and costly projects. It has a low elasticity factor and flexes poorly. Also, printing possibilities are so far limited. Its lifespan is up to 30-40 years. (Pudentz 4, 48–65)

8.53 ETFE Foil

ETFE polymer films are replacing textile fabrics more and more often. They are not textiles but plastic foils and so commonly used that the material deserves to be studied along the coated fabrics. ETFE has excellent mechanical properties and a high fire resistance factor. ETFE can be coloured and printed onto. The lifespan of ETFE is up to 25-35 years and it is an inexpensive material. It is often chosen for pneumatic structures, greenhouses, swimming pool buildings etc.. Its maximum spans are smaller than those of PVC coated polyester and it is not used in large span load bearing structures. (Moritz 2000)

A non-exhaustive list of material developments related to textiles and architextiles

	earliest adhesives, animal and fish bone derivatives, beeswax, gums, egg white and rice products, tar, bitumen, sealing wax
1500's	rubber for proofing material, Latin American Indians
1700's	oil cloth industry, oils on cotton, even silk, England and Germany,
1747	1st raincoat, latex on old overcoat, Francois Fresnau, Frech Gayana
1823	waterproof material with rubber, patent obtained by Charles Machintosh, England
1841	vulcanization of rubber, Charles Goodyear, USA
1843	vulcanization of rubber, Thomas Hancock, Manchester, England
1850's	gun-cotton coating for cotton, nitro-cellulose
1855	1st artificial silk patent, Swiss chemist Audemars, England
1880'a	fibres like carbon filaments, Sir Joseph W. Swan, England
1889	1st regenerated fibre, rayon viscose, French chemist Count Hilaire de Chardonnet
1893	cellulose acetate film, Arthur D. little, Boston
1900	already before the century, studies of chromic materials
1900-	first observations of nanomaterials
1900–1950	several new polymers and synthetic rubbers, also for fabric coatings, polyvinyl chloride (PVC), polychloroprene (Neoprene, DuPont), acrylates, polyurethane
1910	commercial production of rayon started, USA
1910	acetate motion picture films and toilet articles, World War I and cellulose acetate cellulose acetate, "dope", for English airplane wings, invitation to the USA and American warplanes, Camille and Henry Dreyfuss
1920's	70% rise in the markets for regenerated fibres, USA
1924	1st commercial uses for acetate fibre form, Celanese Company, USA
1930	rubber in commercial production in USA
1930's-	hape memory materials (SMMs)
1931	1st synthetic fibres, Nylon 66 by American chemist Wallace Carothers and DuPont
1936	glass fibre production is USA
1938	1st synthetic fibres, Nylon 6 by German Paul Schlack and I. G. Farben
1939	commercial production of Nylon, for example parachute fabrics
1941	all Nylon production for military use, World War II, parachutes, ropes tents, tires, etc.
1945-	end of the war, synthetic fibres market share 15%, USA, nylon for civilian uses, carpeting, automotive industries, clothing, new fibres: metalized fibres, olefins
1946	metallic fibres, USA
1949	Modacrylic, Olefin, USA
1950-	synthetic fibres, 20% share: DuPont produces Acrylic, Polyester
1953	triacetate and polyester
1960's	development of fibres: Spandex, Aramids, carbon fibre, US Space Program and synthetic fibres: Neil Armstrong's nylon and aramid space suit, nylon flag
1960–65	market share of synthetics in USA 30-40%
1970's	flammability standards, NASA research and phase change materials (PCMs)
1980's	high performance fibres
1983	Sulfar and PBI fibres, commercial in USA
1990's	intelligent (smart) materials to common knowledge
1990's-	ptical fibres
2000's	ecological issues of textiles
2002-	photovoltaic energy production grows fastest in the world
2000's	functional, smart and intelligent materials, fibres and textiles
2000's	flexible photovoltaic cells
2005–	printabel photovoltaic cells, thin-film solar panels
2000–2005	worldwide technical textiles consumption up 20% in volume
...	

8.6 A Sample List

The list (figure 50) on the next spread includes some of the most used architectural fabric materials. A few European fabric and film manufacturers were contacted by the author for sample materials. They were asked to provide sample material of the most common architectural fabrics. The samples arrived upon a request for suitable textile and fabric materials for uses in exterior architecture. The listing includes the information of the received materials provided by the manufacturers.

ARCHITECTURAL FABRIC		MATERIAL	COATING / TOPCOAT MATERIAL(S)	WIDTH (cm)	USE	TOTAL WEIGHT (g/m ²)	THICKNESS (mm)	TENSILE STRENGTH (N/5cm)	ELONGATION (warp/weft)	TEAR STRENGTH (warp/weft)	TEMPERATURE RANGE	FIRE RESISTANCY	WATER RESISTANCY	SOLVENT RESISTANCY	LIGHT TRANSMISSION%	LIGHT REFLECTION	LIGHT FASTNESS	UV TRANSMISSION
NAIZIL: SPORT COVER – TYPE 1		HIGH TENACITY POLYESTER	PVC / ROTOFLUO W fluoridised mixed acrylic/resin lacquering	250-300	TENSILE STRUCTURES	720	0,58	3000 / 3000	24 / 30	300 / 300	-30 to +70	B1/DIN 4102-1 B-s1,d0/En 13501-1	IMPERPEABLE / WATER PROOF	RESISTANT	8	86,7	6	0,02
NAIZIL: BIG COVER – TYPE 2		HIGH TENACITY POLYESTER	PVC / ROTOFLUO W fluoridised mixed acrylic/resin lacquering	250-300	LARGE TENSILE STRUCTURES	950	0,75	4000 / 4000	24 / 32	500 / 500	-30 to +70	B1/DIN 4102-1 B-s1,d0/En 13501-1	IMPERPEABLE / WATER PROOF	RESISTANT	5,9	88,4	6	< 0,005
FERRARI: PRECONTRAIINT FLUOTOP 1002 T2		HIGH TENACITY POLYESTER	Fluotop® T2 (High concentration PVDF)	178	TENSILE STRUCTURES	1050	0,78	420 / 400 daN/5cm			-30 to +70	B1/DIN 4102-1 B-s1,d0/En 13501-1				78		0
FERRARI: STAMISOL FT 381		PVC COATED POLYESTER, OPEN FABRIC	PVC	267	FACADES	600		300 / 300 daN/5cm			-30 to +70	B2/DIN 4102-1 B-s2,d0/EN 13501-1						
B 18039		PTFE COATED GLASS EC ¾	PTFE			800	0,5	4200 / 4000		300 / 300								
INTERGLASS: A TEX 3000 TRL		GLASS FIBRE FILAMENT	SILICONE	200-300	TENSILE STRUCTURES, FACADES, sewing, adhesive tapes	595	0,45	3500 / 3000		350 / 300	-50 to +200	B1/DIN 4102-1 B-s1,d0/En 13501-1	CLASS 0 B1		38,4	43,9		
INTERGLASS: A TEX 5000 TRL		GLASS FIBRE FILAMENT	SILICONE	200-300	TENSILE STRUCTURES, FACADES, sewing, adhesive tapes	1165	0,8	5000 / 5000		400 / 400	-50 to +200	B1/DIN 4102-1 B-s1,d0/En 13501-1	CLASS 0 B1		18,4	68,4		
GORE: GORE™ TENARA r		100 % EXPANDED PTFE	X	157	TENSILE STRUCTURES, retractables	330		2390 / 2210				Bs1, d0/EN 13501-1			37	60		

ETFE FOIL		MATERIAL	COATING / TOPCOAT MATERIAL(S)	WIDTH (cm)	USE	TOTAL WEIGHT (g/m ²)	THICKNESS um	1 TENSILE STRENGTH Mpa	2 TENSILE STRESS AT 10% STRAIN Mpa	3 TENSILE STRAIN AT BREAK %	4 TENSILE STRENGTH Mpa	5 TENSILE STRESS AT 10% STRAIN Mpa	6 TENSILE STRAIN AT BREAK %	7 TEAR RESISTANCE N/mm	8 TEAR RESISTANCE N/mm	9 OPACITY %	MELTING POINT (Celsius)	UV TRANSMISSION
NOVOFOL: NOVOFLON ET 6235 Z		FLUORPOLY MERE FILM		max 1550	roofing, covering for solar collectors		100	50	22	400	50	22	500	460	460	2,6	266	
NOVOFOL: NOVOFLON ET 6235 Z		FLUORPOLY MERE FILM		max 1550	roofing, covering for solar collectors		150	55	23	520	55	23	520	480	520	4,5		
NOVOFOL: NOVOFLON ET 6235 Z		FLUORPOLY MERE FILM		max 1550	roofing, covering for solar collectors		200	50	22	550	50	22	550	520	520	5	266	
NOVOFOL: NOVOFLON ET 6235 Z		FLUORPOLY MERE FILM		max 1550	roofing, covering for solar collectors		250	45	23	500	50	23	550	540	540	6,8		
NOVOFOL: NOVOFLON ET 6235 Z		FLUORPOLY MERE FILM		max 1550	roofing, covering for solar collectors		300	54	22	600	54	22	600	520	520	9		
NOVOFOL: NOVOFLON ET 6235 Z WHITE		FLUORPOLY MERE FILM		max 1550	roofing, covering for solar collectors		200	45	22	500	45	22	500	520	520	71		
NOVOFOL: NOVOFLON ET 6235 Z ORANGE		FLUORPOLY MERE FILM		max 1550	roofing, covering for solar collectors		250	42	22	520	45	22	500	470	450	75		

EN 13501-1:2007 has Finnish national standard's status: "Fire classification of construction products and building elements. Part 1: Classification using data from reaction to fire tests"; SFS-EN 13501-1
SFS-EN 13501-1; Class B may have additional classification regarding smoke production (s1, s2, s3) and regarding flaming droplets and/or particles (d0, d1, d2)
B1: difficult to ignite / B2: normal combustibility / s1: no/hardly any smoke production / s2: limited smoke production

50 A list of common architectural fabrics and their essential properties. The information was provided by some of the European fabric manufacturers contacted by the author.

III CONCEPT

TEXTILE MARKET

Textile and Architecture

9 Conclusions

The absence of textile materials in Finnish architecture was one of the catalysts for this study. The aim of the study was to investigate the backgrounds of the two chosen fields, architecture and textile. My goal was to bring together the information on architecture and textile and to form a compact information package of the fields. This study seems to be one of the first attempts to combine architecture and textile into a broad study and to investigate the relationships between the developments of these two separate fields. The objective has also been to find new, even unexpected connections between the conceptual spaces of the fields of study.

Up to the contemporary period we live in now, the use of textile in architecture has mainly been restricted to the high-tech solutions on one hand, and on the other hand to the rather low-tech solutions. The middle ground between these two extremes has not received the attention it deserves. In this thesis, I have promoted the possibilities of textile based solutions in architecture and explored the related future possibilities.

In this thesis, we have made a tour of the history of the use of textile in architecture, starting by a discussion of the structures of the primitive cultures and continuing all the way to the contemporary period. We have discussed the most common structure types important in textile architecture. We have also investigated the development of textile materials and the possibilities for the future use of textiles architecture. The last part of the work consists of a concept "Textile Market" summarizing the findings of the study.

Textile in Architecture

The possible structural forms of textile architecture are many. Textile is often part of the load-bearing structure. The structure types can be divided to lightweight tensile structures, pneumatic structures and structures where the fabric does not function as a load-bearing part of the solution. The latter applications are screens and textile coverings for various architectural purposes. An interesting possibility concerning small to medium size structures is, that textile can be integrated into a self-supporting structure. This enables movable solutions. Textile structures are often made portable.

In the section "Textile in architecture", I have argued that textile can be used in a large number of ways in architecture. Textiles will probably become increasingly popular in the future architecture due to a collection of advantages that solutions based on the use of fabric have when compared

to more traditional solutions. One of these advantages is the portability of the material. This enables a wide range of possibilities in ephemeral architecture. In the future, the need for portable temporary structures will definitely increase, as the pace with which the modern society functions is continuously accelerating. Perhaps the most important advantage of fabric based solutions in architecture is related to fact that the structures are light. In sedentary architecture, textile based solutions were unavoidable in relation to projects requiring very large spatial spans.

Textile for architecture

In modern textile based constructions, fabrics do not play an aesthetic function only. Instead, they play an integral structural role. Fabric structures are often advanced high-tech solutions that often could not have been achieved by the use of any other material. This is rather natural, as the development of textile structures has always been closely related to the demanding requirements of the extreme conditions, for example in the defence industry. Perhaps the most intriguing one of the future possibilities for the use of textile in architecture is provided by the smart materials and their endless exciting properties. Another intriguing possibility concerning textile in architecture is the dynamic nature of the material in relation to shape. Textiles can be used in the creation of architectonic applications without a static shape.

The use of textile in architectural contexts is mostly related to efficiency, be it lightness, flexibility and mouldability or ephemerality. Textile is chosen for its tensile properties compared to the compressive properties of the other construction materials. Textile structures use a minimum amount of material. Textile is logistically efficient. Textile materials can often be a more ecologically friendly solution compared to traditional ones. In addition to the minimal amount of material that textile based solutions require, future textiles are likely to become more and more recyclable. The recent research concentrates on improving the ecological issues related to the material.

From the very beginning of the use of textile materials in architecture, visual entities such as narrative figures, have been incorporated onto the structures built. This field of architecture has always had a narrative side related to it. In the modern society, fabrics are continuously used for advertising purposes. However, much of the potential offered by the use of textiles for the purposes of architecture remain unexplored. Narrative information flow related applications are among the exciting possibilities offered by the use of textile in architecture. Clad in textile, a building can have multiple faces instead of one.

Textile and Architecture

The concept "Textile Market" explores the possibilities brought about by the thesis. Textile Market is an ephemeral event for the modern urban nomads and urban nomad architecture. It combines the latest possibilities textile has to offer with one of the oldest ways of social interaction. It is an architectural forum for textile.

Textile is the most dynamic one of the major materials important in architecture. The ever shifting pace of the liquid modernity has found its counterpart in textile architecture.

10 Concept: Textile Market

The city of Helsinki wishes to make the South Harbour -area a more vibrant and lively place. ALA Architects have designed ideas and possibilities for the uses of this area. In their publication "Kirjava satama" the Market Square has great potential to develop into a vibrant area of recreational entertainment and urban life.

Helsinki has also been appointed the World Design Capital of the year 2012. It seeks to promote the urban everyday life of its inhabitants. The concept "Textile Market" is designed for this event.

"Textile Market" takes place in the Market Square of Helsinki between May the 1st and August the 31st. It functions as a traditional square. It is also a fair concentrating on textile. Furthermore, it is a fair in an environment based on textile architecture. The market is an intriguing example of ephemeral use of public space, combining architecture and textile with urban delights.

The structural objects designed for Textile Market use the latest technology related to textile architecture in small scale prototype applications.



TEXTILE MARKET EVENT TAKES PLACE AT THE MARKET SQUARE OF HELSINKI.

Textile Market

Market Square, Helsinki

1.5.2012 – 31.8.2012

The Bazaar, City Cushions, Geo Bump, Night Bulbs,
Power Wall, Sun Sail Lounge, Text Stool, Whirling Dervishes

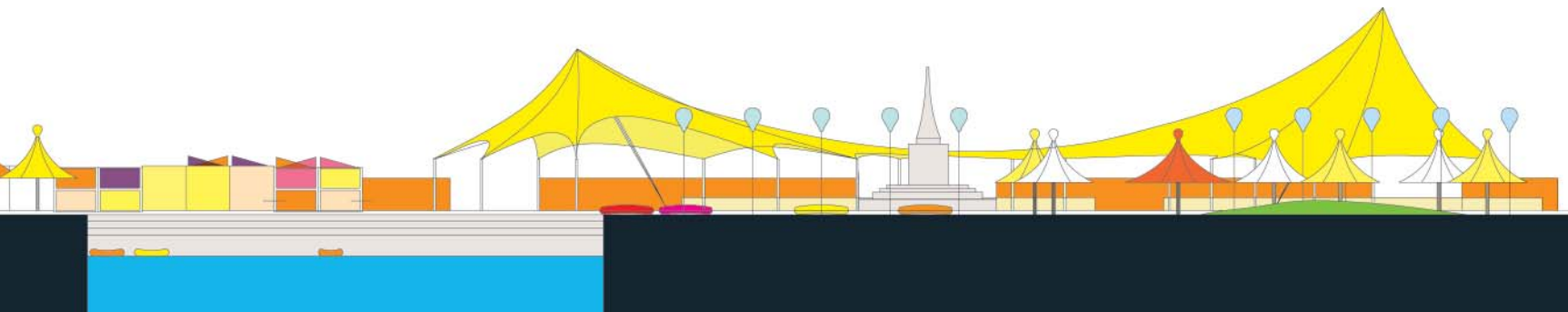

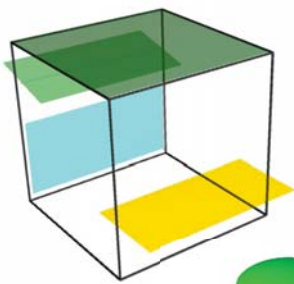

The Bazaar is the core of the market. This is the place where you buy or sell. The modular cells for the use of merchants can be opened or closed in a variety of ways. Changes in temperature and lighting affect the colour of the fabric covering the cells. The fabric is made of ETFE foil laminated with a chromic material layer. The Bazaar is a dynamic piece of art.



City Cushions are pneumatic cushions filled with air or water, thus providing two different modes of tactile experience. The cushions are made of PVC coated polyamid.



Geo Bump is a cozy little bump full of flowers constructed onto a temporary non-woven geotextile substrate.



Night Bulbs are helium filled blobs made of a fluorescent fabric. As the night falls, the bulbs keep glowing.

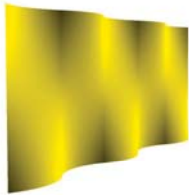

Power Wall is a knitted lace structure that flutters in the wind generating electricity. This is based on the use of piezoelectric fibre technology.



Sun Sail Lounge is the place for relaxing in the hectic urban market. It slows down the flow of people between the city centre and the piers of Katajanokka harbour. The sails are made of vinyl coated polyester with photovoltaic solar panels integrated into it. People can plug in their laptop, mobile phone etc.



Text Stools act as a divide between two different functional areas of the market. The stools also tell you when the Suomenlinna ferry leaves; they have an integrated led based system that can be used for providing information for the passers-by. Turn it over and it is a bench!

Whirling Dervishes are umbrella shades that stay open due to centrifugal forces originating from the spinning motion of the supporting poles. The dervishes are made of a woven PTFE fabric.



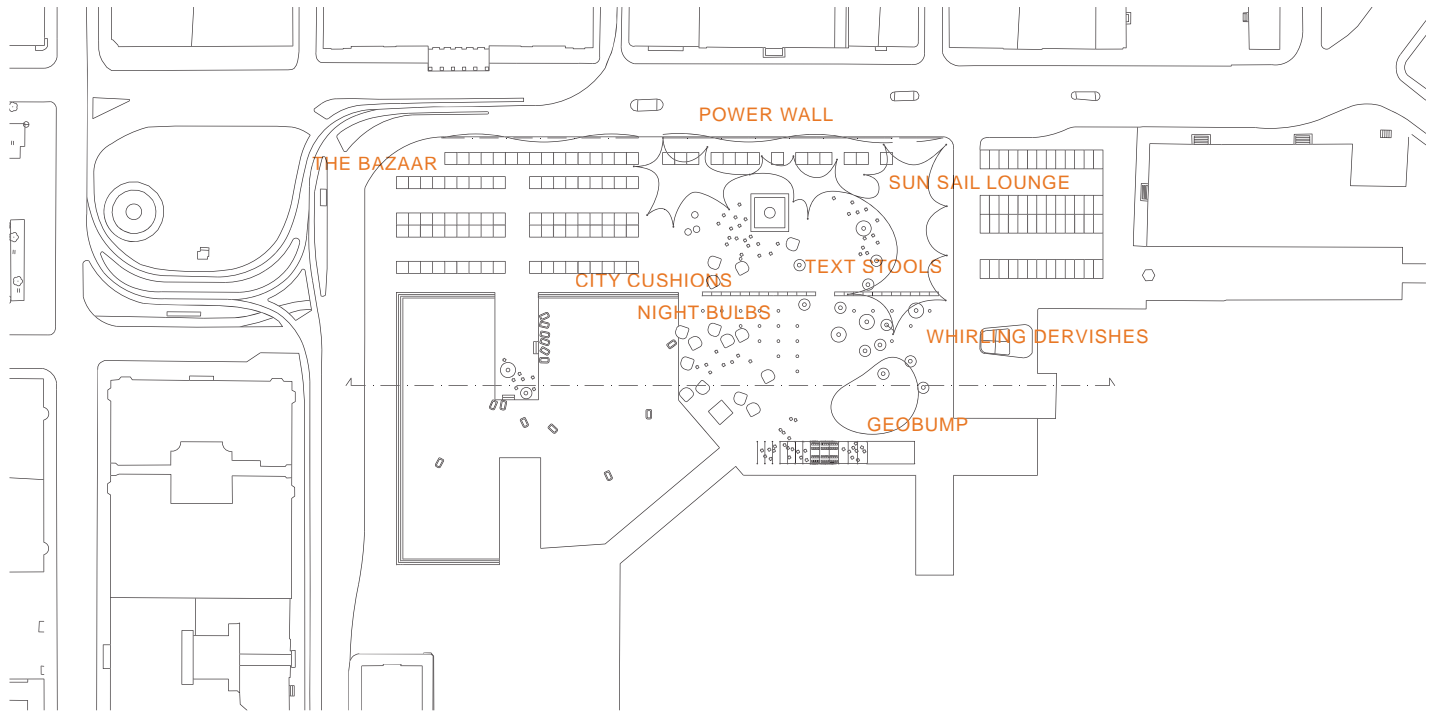

TEXTILE MARKET, PLAN, 1:2000

TEXTILE MARKET, WATERFRONT VIEW, 1:1000





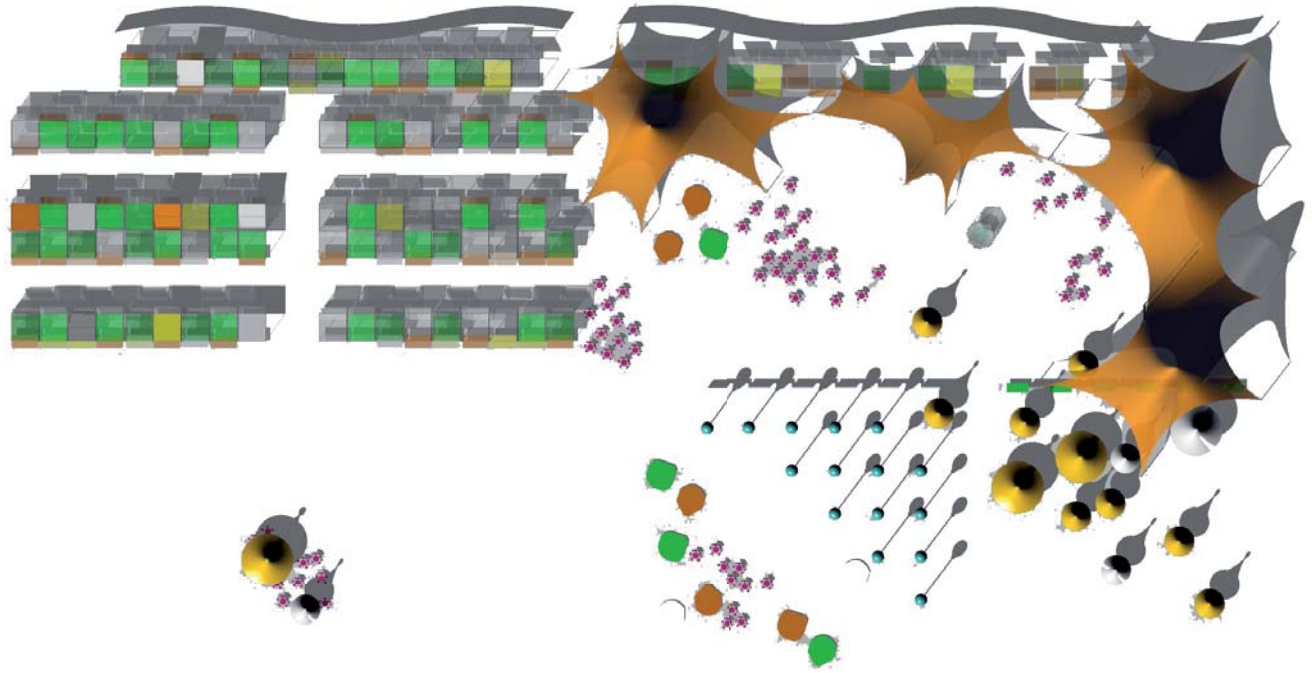

TEXTILE MARKET, TOP VIEW OF THE DIFFERENT FUNCTIONS AND STRUCTURES

TEXTILE MARKET,
VIEW TOWARDS KATAJANOKKA

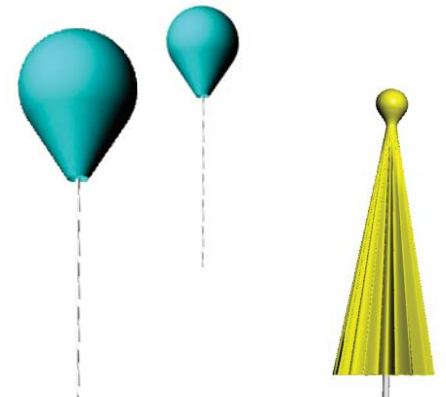



MARKET SQUARE WATERFRONT AERIAL VIEW
TEXTILE MARKET SECTION, 1:1000
PERSPECTIVE FROM THE BAZAAR END OF TEXTILE MARKET

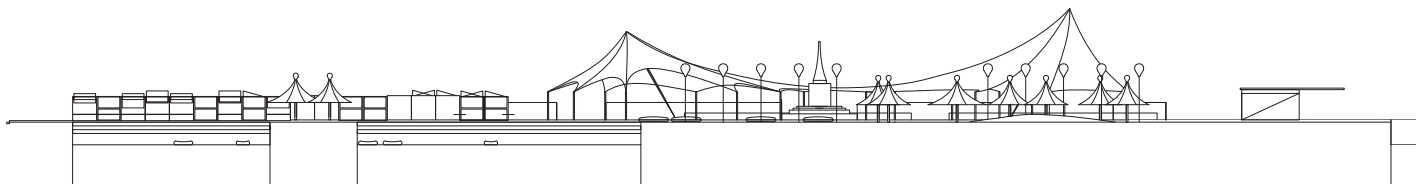



Bibliography

- AD 2006**, 'Architextiles', *Architectural Design* 2006, vol 76 No 6, John Wiley & Sons Ltd, England 2006.
- Adanur S 2001**, *Handbook of Weaving*, Technomic Publishing Company Inc., Lancaster, Pennsylvania, USA.
- Ahmed Al 2007**, 'Non woven fabric finishing', in SJ Russel (ed.), *Handbook of Non wovens*, e-book, Woodhead Publishing Limited, Cambridge, England, viewed 19082008, <<http://www.crcnetbase.com>>.
- Architen Landrill 2008**, *Media Wall, Liverpool City of Culture*, web document, Architen Landrill, UK, viewed 26042010, <<http://www.architen.com/projects/media-wall-liverpool-city-of-culture-2008>>.
- Architen Landrill 2010**, *Spiky Seminar Pod*, web document, Architen Landrill, viewed 19012010, <<http://www.architen.com/projects/spiky-seminar-pod>>.
- arcspace.com 2005**, *Alsop Design/AMEC Blizzard Building*, arcspace.com, viewed 19012010, <<http://www.arcspace.com/architects/alsop/blizzard/blizzard.html>>.
- Armijos S 2009a**, *There are 5 key steps to making your Fabric Structure idea a reality*, web document, viewed 22042009, <<http://fabricar.startlogic.com>>.
- Armijos S 2009b**, *A Fabric Structure must be made like a well tailored suit*, web document, viewed 23042009, <<http://fabricar.startlogic.com/page6.html>>.
- Armijos S 2009c**, *Designing Architectural Fabris Strutures*, web document, viewed 22042009, <<http://fabricar.startlogic.com/page2.html>>.
- Armijos S 2009d**, *Components and Details*, web document, viewed 23042009, <<http://fabricar.startlogic.com/page4.html>>.
- Bahamón A 2004**, *The Magic of Tents Transforming Space*, Harper Design International, New York, USA.
- Beckh M and Barthel R 2009**, *The First Doubly Curved Gridshell Structure - Shukhovs Building for the Plate Rolling Workshop in Vyksa*, Conference Paper, TU München, Munich, Germany, viewed 03022010, <https://www-docs.tu-cottbus.de/bautechnikgeschichte/public/openaccess/beckh_oa.pdf>.
- Bendkowska W 2006**, 'Intelligent textile with PCMs', in HR Mattila (ed.), *Intelligent textiles and clothing*, Woodhead Publishing Ltd, Cambridge, UK.
- Berger H 2005**, *Light Structures – Structures of Light*, authorHOUSE, Bloomington, the United States.
- Birdair 2010a**, *Tensotherm*, web document, Birdair, USA, viewed 23042010, <<http://www.birdair.com/tensileArchitecture/tensotherm.aspx>>.
- Birdair 2010b**, *TiO2*, web document, Birdair, USA, viewed 23042010, <<http://www.birdair.com/tensileArchitecture/TiO2.aspx>>.
- BISFA 2009**, Terminology of man-made fibres, web document, The International Bureau For Standardisation of Man-Made Fibres, Bruxelles, Belgium, viewed 03032010, <http://www.bisfa.org/booklets/BISFA_Terminology2009.pdf>.
- Block I 2010**, 'Textile', in *AccessScience@McGraw-Hill*, viewed 04022010, <<http://www.accessscience.com/content.aspx?searchStr=textile&id=687400>>.
- Byrne C 2000**, 'Technical textiles market - overview', in AR Horrocks & SC Anand (eds), *Handbook of Technical Textiles*, e-book, Woodhead Publishing Limited, Cambridge, England, viewed 02022010, <http://knovel.com/web/portal/browse/display_EXT_KNOVEL_DISPLAY_bookid=926&VerticalID=0>.
- Chi and Pauletti 2009**, An Outline of the Evolution of Pneumatic Structures, research paper, web document, University of Sao Paolo, Sao Paolo, Brazil.
- Clevertex 2005**, Report on Intelligent Textiles, research paper, web document, CLEVERTEX EU project, viewed 04022010, <<http://www.clevertex.net/Image/documents/State%20of%20the%20art.pdf>>.
- Cooper-Hewitt 2005**, Extreme Textiles, viewed 24102009, <http://cooperhewitt.org/EXHIBITIONS/extreme_textiles/site/index.htm>.
- Da Cruz D 1996**, *The Black Tent*, Saudi Aramco World, web document, viewed 16122009, <<http://www.saudiaramcoworld.com/issue/196603/the.black.tent.htm>>.
- David Dexter Associates 2010**, *Spikey_Pod2*, web document, David Dexter Associates, viewed 19012010, <http://www.daviddexter.co.uk/pdfs/project%20sheets/spikey_pod.pdf>.
- Designboom 2010, curtain wall house, web document, viewed 26012010, <http://www.designboom.com/history/ban_curtainwall.html>.
- designbuild-network.com 2010, Queen Mary College, Medical Building, web document, London, United Kingdom, viewed 19012010, <http://www.designbuild-network.com/projects/queen_mary/>.
- Drew F 1976, FREI OTTO Form and Structure, Crosby Lockwood Stables, London, England.
- EDANA 2009a**, *Facts and Figures*, EDANA, web document, Brussels, Belgium, viewed 25082009, <<http://www.edana.org/content/default.asp?PageID=51>>.
- EDANA 2009b**, *What are Non wovens*, EDANA, web document, Brussels, Belgium, viewed 14082009, <<http://www.edana.org/content/default.asp?PageID=33>>.
- EDANA 2009c**, *How they are made*, web document, EDANA, Brussels, Belgium, viewed 14082009, <<http://www.edana.org/content/default.asp?PageID=36>>.
- EDANA 2009d**, *Finishing treatments*, web document, Brussels, Belgium, viewed 14082009, <<http://www.edana.org/content/Default.asp?PageID=43>>.
- EDANA 2009e**, Non woven production statistics 2008, EDANA, press release, Brussels, Belgium, viewed 25082009, <http://www.edana.org/DocShare/docs/1/MIFPPFOABNLLGJODHCDDOJEKPDWBW4DTCIHU34HH76C1T/EDANA/docs/DLS/2008_07_Nonwovens_production_statistics-2008-00376-01.pdf>.
- "fabric" 1996, in Hoard TF (ed.), *The Concise Oxford Dictionary of English Etymology*, Oxford University Press, 1996. *Oxford Reference Online*, Oxford University Press, viewed 02022010,

<http://www.oxfordreference.com/views/SEARCH_RESULTS.html?y=0&q=fabric&category=t27&x=0&ssid=237760783&scope=book&time=0.888178946986731>.

Faegre T 1979, *Architecture of the Nomads*, John Murray Publishers Ltd, London, Great Britain.

FAR frohn&rohas 2010, *WALL HOUSE, Santiago de Chile (2004-2007)*, web document, viewed 24042010, <<http://www.f-a-r.net/projects2.htm>>.

"fibre" 1996, in Hoad TF (ed.), *The Concise Oxford Dictionary of English Etymology*, Oxford University Press, 1996. *Oxford Reference Online*, Oxford University Press, viewed 02022010, <http://www.oxfordreference.com/views/SEARCH_RESULTS.html?y=0&q=fibre&category=t27&x=0&ssid=1173856530&scope=book&time=0.382769250038255&print_preview=1>.

Frampton K 1980, 'Technical transformations: structural engineering 1775-1939', in *Modern Architecture – a critical history*, Thames and Hudson Ltd., London, UK.

FTLsolar 2010, *Datasheet-PowerMod-1200M*, web document, viewed 28042010, <<http://www.ftlsolar.com/pdf/Datasheet-PowerMod-1200M.pdf>>.

Fung W 2002, *Coated and Laminated Textiles*, e-book, Woodhead Publishing Ltd, Cambridge, England, viewed 18042010, <http://www.knovel.com/web/portal/browse/display?_EXT_KNOVEL_DISPLAY_bookid=1067>.

Garcia M 2006a, 'Architecture + Textiles = Architextiles', in *Architectural Design 2006*, vol 76 No 6, John Wiley & Sons Ltd, England, 2006. viewed 24102009, <<http://www.moca.org/museum/exhibitiondetail.php?id=370>>.

Garcia M 2006, 'Otherworldliness: The Pull of Black Velvet, Latex, Tights, Quilts, Tablecloths and Frocks: An Interview with Will Alsop', in M Garcia (ed.), *AD Architextiles*, vol 76 No 6, 36-41, John Wiley & Sons Ltd, England.

GDK 2010, *ag4_Mediamesh_Illumesh_en.pdf*, GDK/ag4/mediafacade GmbH, web document, viewed 28042010, <http://www.medienfassade.com/fileadmin/media/pdf/ag4_Mediamesh_Illumesh_en.pdf>.

Ghosh TK, Dhawan A and Muth JF 2006, 'Formation of electrical circuits in textile structures', in HR Mattila (ed.), *Intelligent textiles and clothing*, Woodhead Publishing Limited, Cambridge, UK.

Greenroof 2010, *What is a green roof?*, web document, Asacndinavian Green Roof Association, Malmö, Sweden. Viewed 04052010, <<http://www.greenroof.se/?pid=19>>.

Grimshaw Architects 2001, *Eden Project*, Grimshaw Architects, web document, viewed 27012010, <http://www.grimshaw-architects.com/launcher.html?in_projectid=>>.

Grimshaw Architects 2010, British Pavilion for Expo 92, web document, viewed 21032010, <<http://www.grimshaw-architects.com/print/projectdata.php?id=30>>.

Göppert K 2004, 'Primary Structures', in K M Koch (ed.) *Membrane Structure*, Prestel Verlag, Munich, Germany.

Habermann K 2004, 'The History of Membrane Building', in K-M Koch (ed.), *Membrane Structures*, Prestel Verlag, Munich, Germany.

Habermann K 2004b, 'Millennium Dome', in K-M Koch (ed.), *Membrane Structures*, Prestel Verlag, Munich, Germany.

Habermann K 2004c, 'Eden project', in K-M Koch (ed.), *Membrane Structures*, Prestel Verlag, Munich, Germany.

Hall ME 2000, 'Finishing of Technical Textiles', in AR Horrocks and SC Anand (eds) *Handbook of Technical Textiles*, e-book, Woodhead Publishing Ltd, Cambridge, UK, viewed 18042010, <http://www.knovel.com/web/portal/browse/display_EXT_KNOVEL_DISPLAY_bookid=926>.

Harlin A and Ferenets M 2006, 'Introduction to conductive materials', in HR Mattila (ed.), *Intelligent textiles and clothing*, Woodhead Publishing Limited, Cambridge, UK.

Holme I 2000, 'Coloration of technical textiles', in AR Horrocks and SC Anand (eds) *Handbook of Technical Textiles*, e-book, Woodhead Publishing Ltd, Cambridge, UK, viewed 10022010, <http://www.knovel.com/web/portal/browse/display_EXT_KNOVEL_DISPLAY_bookid=926>.

Honkala M 2006, 'Introduction to shape memory materials', in HR Mattila (ed.), *Intelligent textiles and clothing*, Woodhead Publishing Limited, Cambridge, UK.

Hopkins Architect 2010, *Schlumberger Cambridge Research Centre*, web document, viewed in 07052010, <http://www.hopkins.co.uk/projects/_13/>.

Hu et. al 2006, 'Temperature sensitive shape memory polymers for smart textile applications', in HR Mattila (ed.), *Intelligent textiles and clothing*, Woodhead Publishing Limited, Cambridge, UK.

INDA 1997/2006, *About Nonwovens, INDA*, web document, Cary, NC, USA, viewed 19082008, <http://www.inda.org/category/nwn_index.html>.

Kronenburg R 1995, *Houses in Motion, The Genesis, History and Development of the Portable Building*, Academy Editions, London, Great Britain.

LeCuyer A 2008, *ETFE: Design and Technology*, Birkhauser, Basel, Switzerland.

MacDonald AJ 2001, *Structure and Architecture*, 2nd edition, Architectural Press, Reed Elsevier Professional Publishing Ltd, Great Britain.

Mather RR and Wilson JIB 2006, 'Solar textiles: production and distribution of electricity coming from solar radiation. Applications', in HR Mattila (ed.), *Intelligent textiles and clothing*, Woodhead Publishing Limited, Cambridge, UK.

McIntyre JE and Daniels PN 1995, *Textile Terms and Definitions*, Tenth Edition, The Textile Institute, Manchester, UK.

Mirafab M 2000, 'Technical Fibres', in AC Horrocks and SC Anand (eds), *Handbook of Technical Textiles*, e-book, Woodhead Publishing Limited, Cambridge, UK, viewed 23022010, <http://www.knovel.com/web/portal/browse/display?_EXT_KNOVEL_DISPLAY_bookid=926>.

MOCA 2006-2007, *Skin + Bones: Parallel Practises in Fashion and Architecture*, viewed 24102009, <<http://www.moca.org/museum/exhibitiondetail.php?id=370>>.

Moritz K 2000, 'Membrane Materials in Building', in *DETAIL Membrane Construction*, 2000:6, Institut für Internationale Architektur-Dokumentation GmbH, München, Germany.

Mumford L 1961, *The City in the History*, Secker and Warburg, London, England.

Mäkinen M 2006, 'Introduction to phase change materials', in HR Mattila (ed.), *Intelligent textiles and clothing*, Woodhead Publishing Limited, Cambridge, UK.

Norberg-Schultz C 1980, *Meaning in Western Architecture*, Rizzoli International Publications Inc., New York, USA.

Otto F et. al 1982, *Natürliche Konstruktionen*, Deutsche Verlags-Anstalt GmbH, Stuttgart, Germany.

Paoli C 2007, *Past and Future of Grid Shell Structures*, Master's thesis, web document, MIT, USA, viewed 23042010, <<http://dspace.mit.edu/bitstream/handle/1721.1/39277/170977058.pdf?sequence=1>>.

Polyfab 2010, Comshade, web document, Polyfab, Australia, viewed 29042010, <<http://www.polyfab.com.au/11684.htm>>.

Pudentz J 2004, Material and Workmanship, in K-M Koch (ed.), *Membrane Structures*, Prestel Verlag, Munich, Germany.

Ritter A 2006, 'smart materials', Birkhäuser, Berlin, Germany.

Rogers Stirk Harbour 2010, *Millennium Dome*, Rogers Stirk Harbour, London, UK, viewed 18012010, <<http://www.richardrogers.co.uk/render.aspx?siteID=1&navIDs=1,4,23,660>>.

Schoeser M 2003, *World Textiles – A Concise History*, Thames & Hudson Ltd, London, England.

Semper G 1860–1879, *The Four Elements of Architecture and other writings*, Cambridge University Press, England 1989.

SFS 2942, Tekstiilit. Luonnonkuitu. Nimikkeistö., Standardi, Suomen standardisoimisliitto.

SFS-EN 13501-1, Rakennustuotteiden ja osien paloluokitus. Osa 1: Palokäyttäytymiskokeiden tuloksiin perustuva luokitus. Standardi, Suomen standardisoimisliitto.

Shigeru Ban Architects 2010, CURTAIN WALL HOUSE – Tokyo, Japan, 1995, viewed 26012010, <http://www.shigerubanarchitects.com/SBA_WORKS/SBA_HOUSES/SBA_HOUSES_15/SBA_Houses_15.html>.

Sondheim WS 2000, 'Technical fabric structures – Woven fabrics', in AR Horrocks & SC Anand (eds), *Handbook of Technical Textiles*, e-book, Woodhead Publishing Limited, Cambridge, England, viewed 14 February 2009, <http://knovel.com/web/portal/browse/display?_EXT_KNOVEL_DISPLAY_bookid=926&VerticalID=0>.

Spencer D 2001, *Knitting Technology - A Comprehensive Handbook and Practical Guide*, Woodhead Publishing Limited, Cambridge, England.

Spencer D 2001, 'An Introduction to Textile Technology', in D Spencer (ed.), *Knitting Technology – A Comprehensive Handbook and Practical Guide (3rd Edition)*, e-book, Woodhead Publishing Limited, Cambridge, England, viewed 08092010, <http://www.knovel.com/web/portal/basic_search/display?_EXT_KNOVEL_DISPLAY_bookid=1068>.

Talvenmaa P 2006, 'Introduction to chromic materials', in HR Mattila (ed.), *Intelligent textiles and clothing*, Woodhead Publishing Limited, Cambridge, UK.

Tao X 20001, 'Smart technology for textiles and clothing: Introduction and overview', in X Tao (ed.), *Smart Fibres, Fabrics and Clothing*, e-book, Woodhead Publishing Limited, Cambridge, England, UK, viewed 19022010, <http://www.knovel.com/web/portal/browse/display?_EXT_KNOVEL_DISPLAY_bookid=819>.

Techtextil 2010, *Application areas*, web document, viewed 17022010, <<http://techtextil.messefrankfurt.com/frankfurt/en/aussteller/messeprofil/anwendungsbereiche.html>>.

Tensinet 2010a, Haj Terminal of the Jeddah International Airport, Tensinet, web document, viewed 19012010, <<http://www.tensinet.com/database/viewProject/3859.html>>.

Tensinet 2010b, *The Eden Project*, Tensinet, web document, viewed 27012010, <<http://www.tensinet.com/database/viewProject/4185.html>>.

Tensinet 2010c, *Fuji Pavilion*, web document, viewed 23012010, <<http://www.tensinet.com/database/viewProject/3765>>.

Tensinet 2010d, Schlumberger Cambridge Research Centre, web document, viewed 07052010, <<http://www.tensinet.com/database/viewProject/3765>>.

"**textile**" 1996, in Hoad TF (ed.), *The Concise Oxford Dictionary of English Etymology*, Oxford University Press, 1996. Oxford Reference Online, Oxford University Press, viewed 02022010, <<http://www.oxfordreference.com/views/ENTRY.html?subview=Main&entry=t27.e15478>>.

The Textile Institute's Terms and Definitions Committee, *Textile terms and Definitions*, 10th edition, The Textile Institute, Machester, England, 1995.

Textile World 2009, *Quality Fabric of the Month*, Textile World, web document, viewed 23042010, <http://www.textileworld.com/Articles/2009/June/QFOM_Kenaf_From_Temporary_Tensile_Architecture_Into_Paper_Products.html>.

Wakefield D 2004, 'Membrane Engineering', in K-M Koch (ed.), *Membrane structures*, Prestel Verlag, Munich, Germany.

Wilson A 2007, 'Development of the unwoven industry', in SJ Russel (ed.), *Handbook of Nonwovens*, e-book, Woodhead Publishing Limited, Cambridge, England, viewed 14082008, <<http://www.crcnetbase.com>>.

Illustration Credits

- I www.husseinchalayan.com (www.husseinchalayan.com/download.php?filename=data/collections/2000/2000_a_w_af-ter_words/HC_AW00024.jpg)
- II www.metmuseum.org (www.metmuseum.org/toah/works-of-art/2006.251a-c)
- III www.tekniikkatalous.fi (www.tekniikkatalous.fi/multimedia/dynamic/00030/bmw_gina_30974c.jpg)
- 1 Faegre 1979, 22&19
- 2 Kronenburg 1995, 20
- 3 Faegre 1979, 156
- 4 Berger 2005, 27
- 5 Kronenburg 1995, 36
- 6 Otto 1976, 23
- 7 Habermann 2004, 24
- 8 Habermann 2004, 27
- 9 Otto 1976, 24
- 10 Kronenburg 1995, 54
- 11 Berger 2005, 36
- 12 MacDonald 2001, xii
- 13 Otto 1979, 64
- 14 Otto 1979, 64
- 15 Otto 1979, 66
- 16 LeCuyer 2008, 11
- 17 LeCuyer 2008, 12
- 18 LeCuyer 2008, 15
- 19 Beckh&Barthel 2009
- 20 Pasquerella 2010 (<http://www.lakehurst.navy.mil/nlweb/images/1213d.gif>)
- 21 LeCuyer 2008, 21
- 22 LeCuyer 2008, 25
- 23 Otto 1979, 49
- 24 Otto 1979, 49
- 25 Davis&Brody/www.columbia.edu ([Davis&Brody/www.columbia.edu/cu/gsap/BT/DOMES/OSAKA/struct.html](http://www.columbia.edu/cu/gsap/BT/DOMES/OSAKA/struct.html))
- 26 Davis&Brody/www.columbia.edu ([Davis&Brody/www.columbia.edu/cu/gsap/BT/DOMES/OSAKA/struct.html](http://www.columbia.edu/cu/gsap/BT/DOMES/OSAKA/struct.html))
- 27 www.tensinet.com (www.tensinet.com/project_files/3765/EXPO70_OSAKA_KOYGO_FUJI_G_DS01.jpg)
- 28 www.tensinet.com (www.tensinet.com/project_files/3765/EXPO70_OSAKA_KOYGO_FUJI_G_PV04.jpg)
- 29 Jo Reid & John Peck/ www.grimshaw-architects.com ([Jo Reid & John Peck/www.grimshaw-architects.com/images/152.jpg](http://www.grimshaw-architects.com/images/152.jpg))
- 30b www.som.com (www.som.com/local/common/modules/gallery/dsp_image_gallery.cfm/king_abdul_aziz_international_airport_hajj_terminal?galleryCategoryID=504246&ImageIndex=3)
- 30a Berger 2004, 98
- 31 <http://www.hopkins.co.uk>/usr/images/projects/13/project_page/scr_03.jpg
- 31b www.tensinet.com/project_files/3759/SCHLUM_CAMBRI_HOPKIN_RESEAR_DV01.jpg
- 32 bakgård.blogspot.com 2008 (<http://bakgard.blogspot.com/2008/07/fabric-as-walls.html>)
- 33 www.richardrogers.co.uk (<http://www.richardrogers.co.uk/render.aspx?siteID=1&navIDs=1,4,25,661&showImages=detail&sortBy=&sortDir=&imageID=1740>)
- 34 www.birdair.com/ Larson OBrien Advertising (<http://www.birdair.com/downloads/designDetails.aspx>, Larson OBrien Advertising)
- 35 Stevekeiretsu 2001. Wikimedia commons: Ed d2s 2006. CC-BY-2.5
- 36 LeCuyer 2008,67
- 37 www.architen.com(http://www.architen.com/projects/spiky-seminar-pod/portraitPhoto1_medium)
- 38 Byrne 2000, 4-5
- 39 Byrne 2000, 4
- 40 GDK 2010
- 41 FTLsolar 2010
- 42Mirafab 2000, 29
- 43 Mirafab 2000, 34
- 44 GDK 2010
- 45 Polyfab 2010 (<http://www.polyfab.com.au/bruce-rock-comsh-300.jpg>)
- 46 Greenroof 2010 (<http://www.greenroof.se/data/archive/files/Storl.-267-x-200/P9070005.jpg>)
- 47 FAR frohn&rohas 2010, Cristobal Palma (www.designboom.com/contemporary/FAR/09.jpg)
- 48 Architen Landrill 2008
- 49 Architen Landrill 2008

The pictures unlisted belong to the author.

Appendices

Appendix 1

Natural Fibres

The most propable fibres for architectural uses are marked.

NATURAL FIBRES

ANIMAL FIBRES	PLANT FIBRES/ SEED FIBRES	MINERAL FIBRES
wool	cotton	asbestos
alpaca	kapok	
angora	STEM FIBRES	
camel	flax	
cashmere	hemp	
lama	jute	
mohair	ramie	
vicuna	broom	
guanaco	LEAF FIBRES	
yak	manila, abaca	
hair	sisal	
silk	alfa	
	FRUIT FIBRES	
	coir	

according to standard SFS 2942, based on ISO 6938-1984

Appendix 2

Generic Names of Man-made Fibres

The most propable fibres for architectural uses are marked.

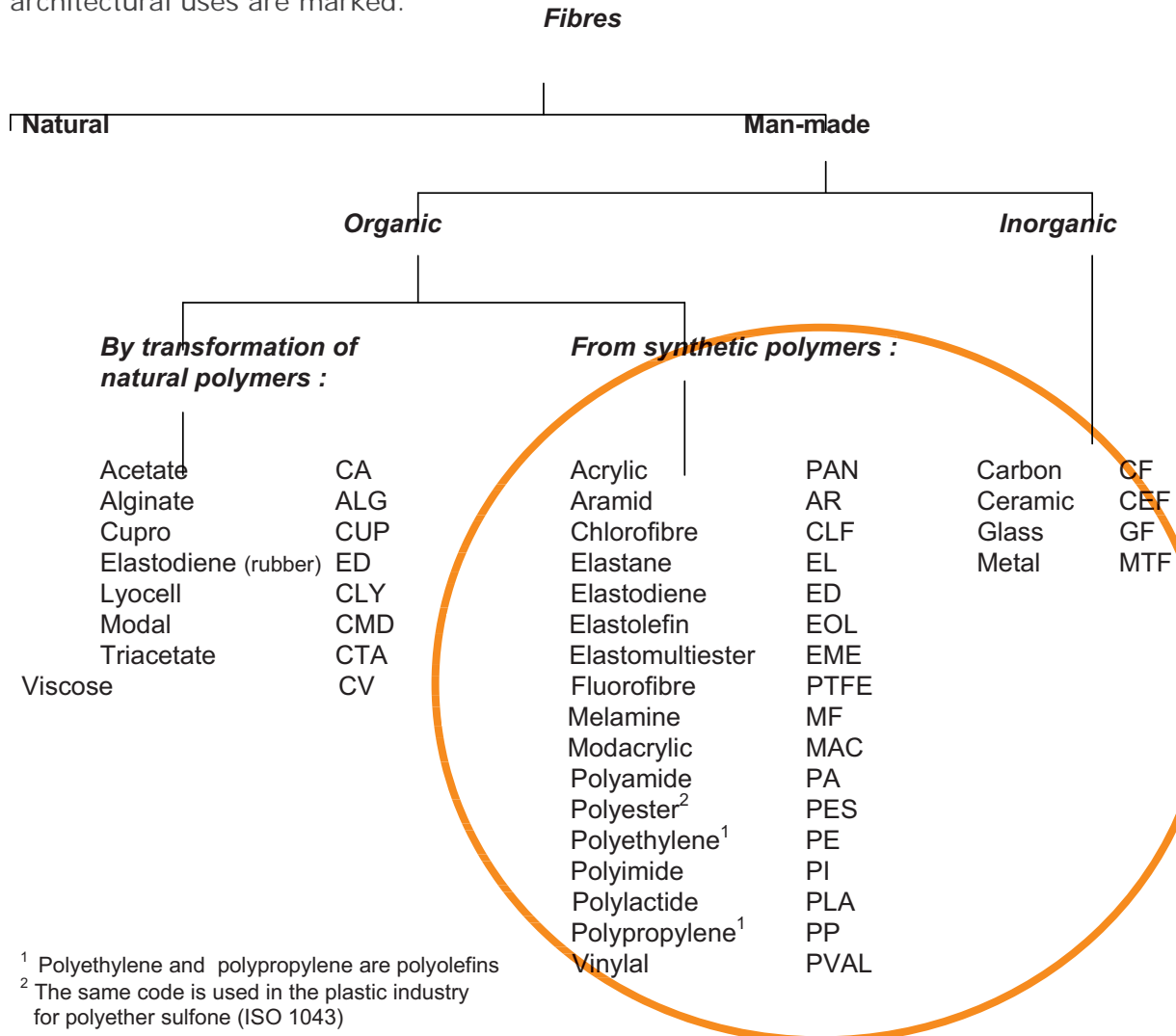

Source: BISFA 2009 Terminology

