



ALEKSI REITO

Metal-on-Metal Hip Resurfacing

Medium-term results, prevalence and risk factors
for adverse reaction to metal debris



ACADEMIC DISSERTATION

To be presented, with the permission of
the Board of the School of Medicine of the University of Tampere,
for public discussion in the Small Auditorium of Building B,
School of Medicine of the University of Tampere,
Medisiinarinkatu 3, Tampere, on December 5th, 2014, at 12 o'clock.

UNIVERSITY OF TAMPERE

ALEKSI REITO

Metal-on-Metal Hip Resurfacing

Medium-term results, prevalence and risk factors
for adverse reaction to metal debris

Acta Universitatis Tamperensis 1964
Tampere University Press
Tampere 2014



UNIVERSITY
OF TAMPERE

ACADEMIC DISSERTATION
University of Tampere, School of Medicine
Coxa Hospital for Joint Replacement
Finland

Supervised by

Docent Antti Eskelinen
University of Tampere
Finland
Docent Timo Puolakka
University of Tampere
Finland

Reviewed by

Professor Heikki Kröger
University of Eastern Finland
Finland
Docent Hannu Miettinen
University of Eastern Finland
Finland

The originality of this thesis has been checked using the Turnitin OriginalityCheck service in accordance with the quality management system of the University of Tampere.

Copyright ©2014 Tampere University Press and the author

Cover design by
Mikko Reinikka

Distributor:
kirjamynti@juvenes.fi
<http://granum.uta.fi>

Acta Universitatis Tamperensis 1964
ISBN 978-951-44-9543-4 (print)
ISSN-L 1455-1616
ISSN 1455-1616

Acta Electronica Universitatis Tamperensis 1449
ISBN 978-951-44-9544-1 (pdf)
ISSN 1456-954X
<http://tampub.uta.fi>

Suomen Yliopistopaino Oy – Juvenes Print
Tampere 2014



Abstract

In the early 2000s metal-on-metal (MoM) bearings became a subject of renewed interest due to advances in tribology and metallurgy. Contemporary MoM bearings had shown a 40-100 fold reduction in bearing wear compared to metal-on-polyethylene bearings. Anticipated low wear and large femoral diameter mimicking native femoral anatomy were deemed optimal qualities in hip implants for young and active patients requiring hip replacement surgery. This led to a rapid increase in the use of MoM hip resurfacings (HR), and later on large-diameter (LD) MoM total hip replacements (THR).

The aims of Study I were to investigate the mid-term clinical and radiological results, as well as survival rate of Birmingham Hip Resurfacing (BHR), the most common contemporary HR to date. To achieve our aims, all patients with a BHR implant were evaluated using patient reported outcome scores (PROMs), a satisfaction questionnaire and plain radiographs. In order to supplement current radiological quantitative methods we developed a novel method to assess acetabular cup version in plain radiographs. In Study II, we investigated the usefulness and reliability of this new method. In Study III, mid-term clinical results and survivorship of MoM HR were investigated in a cohort of young patients (aged 40 or less) using PROMs. Further, we aimed to study prevalence and risk factors for adverse reaction to metal debris (ARMeD) in patients who had received either an HR device or an LD THR (Study IV). To achieve this, all patients with a recalled high-risk MoM device underwent a mass screening programmes consisting of PROMs, blood metal ion (cobalt and chromium) measurements and cross-sectional imaging to detect possible ARMeD. Further, a modified screening programme was implemented in patients with a BHR device to evaluate the usefulness of a targeted screening programme to detect ARMeD (Study V). In the same study, the ten year survivorship after BHR was also assessed.

In Study I the six-year survival rate of BHR was 96.7%. Clinical outcome was satisfactory based on Harris Hip Score and patient satisfaction. Study II showed that intra-observer correlation for version and inclination measurement ranged from 0.74 to 0.97. The intraclass correlation coefficient for version and inclination among four observers was 0.79 and 0.91, respectively. In Study III the seven-year

survival rate of HR in patients aged 40 or less was 90.5%. Seven out of eight reoperations were due to ARMeD. Again, clinical outcome was satisfactory based on the Harris Hip Score and patient satisfaction. Patients with comorbidity had lower Harris Hip Score, activity level and poorer quality of life than patients without comorbidities. According to Study IV the prevalence of failure was high among patients with ASR hip replacement owing to 34% of hips being revised, the majority due to ARMeD. The seven-year survival rate for the HR and THR cohorts was 51% and 38% respectively. Reduced cup coverage was an independent risk factor for ARMeD in both cohorts. High preoperative range of motion, stem type, and female gender were associated with an increased risk of ARMeD only in patients undergoing THR. After targeted screening for ARMeD in patients with BHR in Study V, symptomatic patients with elevated metal ion levels evinced the highest prevalence (63%) of pseudotumours compared with asymptomatic patients with elevated metal ion levels (42%) and symptomatic patients with nonelevated metal ions (11%). Ten-year survival rate of BHR after screening protocol was 91%.

The mid-term survival rate and clinical outcome of BHR was satisfactory and comparable to those reported in earlier studies. Assessment of cup orientation using our novel method from plain radiographs proved useful with contemporary HRs. Clinical outcome and quality of life was excellent in patients aged 40 or less with HR. Cumulative survival rate, however, was higher than acceptable in this subcohort. Moreover, the prevalence of ARMeD was high in patients who had received the recently recalled ASR hip replacement device. Risk factors for ARMeD differed between hip resurfacing procedures and THRs. Our results suggest a more complicated failure mechanism in THAs than in hip resurfacing procedures. Contrary to current guidelines, routine metal ion measurement proved to be useful in detecting pseudotumours in patients with well-functioning hip resurfacing, namely BHR. Moreover, the ten-year survival rate of BHR in male patients was acceptable. Further follow-up and additional research are required to confirm our present results implying the assessment of the survivorship and true prevalence of ARMeD in up to 15 years of follow-up to ascertain the role of MoM hip resurfacing in the treatment of severe hip destruction in young active patients.

Tiivistelmä

Perinteisten metalli-muoviliukuparia käyttävien lonkkatekonivelten huonot tulokset nuorilla ja aktiivisilla potilailla johtivat eri tekonivelkonseptien aktiiviseen kehitystyöhön 1990-luvun loppupuolella. Suuret toiveet kohdistuivat erityisesti kokometallisiin lonkan pinnoitetekoniveliin, joissa tribologian ja metallurgian kehityksen myötä oli laboratorio-olosuhteissa todettu lupaavia tuloksia: kokometallisella liukuparilla kuluminen oli 40 – 100 kertaa vähäisempää perinteiseen metalli-muoviliukupariin verrattuna. Erittäin vähäisen kulumisen lisäksi pinnoitetekonivelen reisiluukomponentin nuppikoko vastasi lähes anatomista reisiluun pään halkaisijaa. Nämä olivat molemmat toivottuja ominaisuuksia, joiden ajateltiin olevan ideaalisia erityisesti nuorille ja aktiivisille lonkan tekonivelleikkauksen tarvitseville potilaille. Alustavien kliinisten tulosten oltua lupaavia kokometallisten pinnoitetekonivelten käyttö lisääntyi nopeasti 2000-luvun alussa maailmanlaajuisesti. Tämä suuri kokometallinen liukupari otettiin nopeasti käyttöön myös ns. perinteisessä varrellisissa lonkkatekonivelissä. Vuonna 2008 alkoi kuitenkin ilmaantua ensimmäisiä tutkimustuloksia, joiden mukaan ”metal-on-metal” (MoM) -tekonivelen saaneilla potilailla oli havaittu uudentyyppisiä ongelmia, ns. haitallisia metallireaktioita. Metallireaktio tarkoittaa tekonivelen kokometallisesta liukupinnasta irtoavan metallihiukkasten ja niistä liukenevien metalli-ionien aiheuttamaa lonkan ympäruskudosten inflammatorista reaktiota.

Ensimmäisen osatyön tavoitteena oli selvittää Suomessa yleisimmin käytetyn pinnoitetekonivelen, Birmingham Hip Resurfacing (BHR), keskipitkän aikavälin kliiniset ja radiologiset tulokset sekä kiinnipysyvyys. Toisessa osatyössä selvitettiin kehittämämme uuden radiologisen mittaumenetelmän hyödyllisyyttä lonkkatekonivelen kuppiosan asennon arvioimisessa tavallisista lantion natiiviröntgenkuvista. Kolmannessa osatyössä arvioitiin pinnoitetekonivelen kliiniset tulokset ja kiinnipysyvyys nuorilla, alle 40-vuotiailla potilailla. Lisäksi tässä väitöstutkimuksessa pyrittiin selvittämään metallireaktion esiintyvyyttä ja riskitekijöitä niillä potilailla, joilla oli lonkan ensitekonivelleikkauksessa käytetty kokometallista ASR -pinnoite- tai kokotekonivelmallia, joka on vedetty pois markkinoilta havaittujen ongelmien vuoksi (osatyö 4). Kaikki nämä potilaat

kutsuttiin seulontatutkimuksiin, joissa kliinisen tutkimuksen ja lonkan tavanomaisten röntgenkuvien lisäksi määritettiin potilaiden veren koboltti- ja kromipitoisuudet, ja heille tehtiin myös lantion magneettitutkimus mahdollisen metallireaktion diagnostisoimiseksi. Samaa seulontamenetelmää sovellettiin myös viidennessä osatyössä, jossa arvioitiin BHR- pinnoitetekonivelen saaneilla potilailla metallireaktion seulonnan vaikuttavuutta ja ko. tekonivelen pysyvyyttä kymmenen vuoden seurannassa.

Ensimmäisessä osatyössä todettiin BHR -pinnoitetekonivelen kuuden vuoden kiinnipysyvyydeksi 96.7%. Leikkauksen toiminnallinen tulos oli hyvä Harris Hip Score -toimintakykymittarin ja potilastyytyväisyyskyselyn perusteella. Toisessa osatyössä todettiin, että kehittämämme menetelmä lonkkatekonivelen kuppiosan asennon mittaamiseksi tavallisista lantion röntgenkuvista oli toistettava ja luotettava. Kolmannessa osatyössä pinnoitetekonivelen seitsemän vuoden kiinnipysyvyys nuorilla (alle 40-vuotiailla) potilailla oli 90.5%. Suurin osa näille potilaille seuranta-aikana tehdyistä uusintaleikkauksista jouduttiin tekemään metallireaktion vuoksi. Leikkauksen toiminnallinen tulos oli hyvä Harris Hip Score -toimintakykymittarin perusteella arvioituna ja myös potilastyytyväisyys oli hyvällä tasolla. Liitännäissairauksien todettiin huonontavan leikkauksen toiminnallista tulosta, ja näiden potilaiden elämänlaatu oli myös heikompi kuin sellaisten potilaiden, joilla ei ollut liitännäissairauksia. Neljännessä osatyössä todettiin, että markkinoilta poisvedetyn ASR -kokometallisen lonkkatekonivelen saaneilla potilailla esiintyi runsaasti metallireaktioita. Suurin osa näille potilaille tehdyistä uusintaleikkauksista johtui nimenomaan metallireaktiosta. Tässä alle 50 millimetrin nuppikoon potilasaineistossa tekonivelen seitsemän vuoden kiinnipysyvyys pinnoitetekonivelen saaneilla potilailla oli 51% ja varrellisen kokotekonivelen saaneilla vain 38%. Molemmissa potilasryhmissä lonkkatekonivelen kuppiosan huonon katteisuus oli itsenäinen riskitekijä metallireaktion kehittymiselle. Tavanomaista suurempi lonkan liikkuvuus ennen leikkausta, tekonivelen reisiluosan tyyppi ja naissukupuoli olivat lisäksi itsenäisiä metallireaktion riskitekijöitä varrellisen kokotekonivelen saaneilla potilailla. Viidennessä osatyössä todettiin, että niillä potilailla, joilla tekonivellonkan kipujen lisäksi veren metallionipitoisuudet olivat koholla, löytyi todennäköisimmin (63%:lla) metallireaktioon sopivia löydöksiä lonkan magneettikuvauksessa. Kohdistetun seulonnan jälkeen BHR-tekonivelen kiinnipysyvyys oli 91% kymmenen seurantavuoden jälkeen.

Yhteenvetona voidaan todeta, että tutkimuksessamme BHR-tekonivelen saaneilla potilailla keskipitkän aikavälin kiinnipysyvyys ja leikkauksen toiminnallinen tulos olivat hyvät, mikä on linjassa aiempien aiheesta julkaistujen tutkimusten

kanssa. Lonkkatekonivelen kupin asennon määrittämiseen kehittämämme menetelmän toistettavuus ja tarkkuus olivat hyvät, ja menetelmän voitiin todeta soveltuvan kliiniseen käyttöön. Alle 40-vuotiailla pinnoitetekonivelen saaneilla potilailla leikkauksen toiminnallinen tulos ja elämänlaatu olivat hyvät. Tässä potilasryhmässä tekonivelen kiinnipysyvyys seitsemän vuoden kohdalla oli kuitenkin välttävä. Metallireaktion esiintyvyys todettiin erittäin korkeaksi niillä potilailla, jotka oli ensileikkauksessa asennettu myöhemmin markkinoilta poisvedetty kokometallinen ASR -lonkkatekonivel. Metallireaktion riskitekijät olivat erilaiset pinnoitetekonivelen saaneilla potilailla verrattuna niihin potilaisiin joilla oli asennettu varrellinen kokometallinen tekonivel. Varrellisissa lonkkatekonivelissä metallihiukkasia voi irrota paitsi nivelen liukupinnalta niin myös varren ja nuppiosan liitoskohdasta, mikä todennäköisesti selittää todetun eron riskitekijöissä ryhmien välillä. Vastoin tämän hetkisiä kansainvälisiä hoitosuosituksia, mutta kotimaista hoitosuositusta tukien, veren metalli-ionitasojen säännönmukainen mittaaminen kokometallisen tekonivelen saaneilla potilailla osoittautui hyödylliseksi metallireaktion seulontatutkimukseksi myös niillä potilailla, joille oli asennettu BHR-pinnoitetekonivel. Kymmenen vuoden kiinnipysyvyys BHR-tekonivelen saaneilla potilailla oli aineistossamme hyväksyttävällä tasolla. Lisää tutkimusta tarvitaan pinnoitetekonivelen kiinnipysyvyyden ja metallireaktion esiintyvyyden selvittämiseksi pidemmässä, vähintään 15 vuoden seurannassa, jotta pinnoitetekonivelen rooli ja turvallisuus nuorten potilaiden lonkan nivelrikon hoitovaihtoehtona voidaan luotettavasti arvioida.

List of original publications

- I. Reito A, Puolakka T, Pajamäki J. Birmingham hip resurfacing: five to eight year results. *Int Orthop*. 2011;35(8):1119-24.
- II. Reito A, Puolakka T, Paakkala A, Pajamäki J. Assessment of inter- and intra-observer reliability in the determination of radiographic version and inclination of the cup in metal-on-metal hip resurfacing. *Int Orthop*. 2012;36(3):519-25.
- III. Reito A, Eskelinen A, Puolakka T, Pajamäki J. Results of metal-on-metal hip resurfacing in patients 40 years old and younger. *Arch Orthop Trauma Surg*. 2013;133(2):267-73.
- IV. Reito A, Puolakka T, Elo P, Pajamäki J, Eskelinen A. High prevalence of adverse reactions to metal debris in small-headed ASR™ hips. *Clin Orthop Relat Res*. 2013;471(9):2954-61.
- V. Reito A, Puolakka T, Elo P, Pajamäki J, Eskelinen A. Outcome of Birmingham Hip Resurfacing at 10 years: the role of routine blood metal ion measurements in screening for pseudotumors. *Int Orthop*. 2014;38(11):2251-7.

Abbreviations

ALVAL = aseptic lymphocyte-vasculitis associated lesions

ARMeD = adverse reaction to metal debris

ASR = Articular surface replacement

BHR = Birmingham Hip resurfacing

CI = confidence interval

Co = cobalt

CoCr = cobalt-chrome (alloy)

Cr = chrome

FA = functional arc

HA = hydroxyapatite

HHS = Harris hip score

HR = hip resurfacing

LD = large-diameter

MARS = magnetic artefact reduction sequence

MoM = metal-on-metal

MoP = metal-on-cross-linked polyethylene

MRI = Magnetic Resonance Imaging

OA = Osteoarthritis

OHS = Oxford Hip Score

ON = Osteonecrosis

PE = polyethylene

PT = pseudotumour

ROM = range of motion

THR = total hip replacement

UCLA = university of California, Los Angeles

WB = whole blood

Contents

Abstract.....	3
Tiivistelmä	5
List of original publications	8
Abbreviations.....	9
1 Introduction	13
2 Review of the literature	15
2.1 Evolution of metal-on-metal bearings.....	15
2.2 Evolution of metal-on-metal hip resurfacing.....	17
2.3 Cup orientation in THR and in HR.....	20
2.3.1 Assessment of cup orientation.....	20
2.3.1.1 Planar radiographs.....	20
2.3.1.2 Computed tomography.....	21
2.3.2 Clinical significance of cup orientation.....	22
2.4 Results of metal-on-metal hip resurfacing	23
2.4.1 Survival of HR.....	23
2.4.2 Clinical results of BHR.....	29
2.5 Proposed advantages of HR.....	32
2.5.1 Hip biomechanics.....	32
2.5.2 Revision to THR.....	32
2.5.3 Range of motion.....	33
2.5.4 Stability.....	34
2.5.5 Bone mineral density.....	35
2.6 Total hip replacement in patients younger than 40 years	36
2.6.1 Influence of age on the factors affecting the outcome of THR	36
2.6.2 Outcomes of HR in patients aged 40 years or less	40
2.7 Adverse reaction to metal debris	41
2.7.1 Historical aspects.....	41
2.7.2 Risk factors	41
2.7.2.1 Wear and metal ion levels	41
2.7.2.2 Acetabular inclination and version.....	42
2.7.2.3 Femoral head diameter.....	43
2.7.2.4 Modularity	43
2.7.2.5 Demographic variables.....	44
2.7.3 Histopathogenesis	44
2.7.4 Systemic exposure to metal ions	45
2.7.5 Metal ion levels	46
2.7.6 Cross-sectional imaging.....	48
2.7.6.1 Early reports.....	48

2.7.6.2	MRI.....	48
2.7.6.3	Ultrasonography.....	49
2.7.7	Operative findings.....	50
3	Aims of the present study.....	52
4	Patients and methods.....	53
4.1	Patients.....	53
4.2	Methods.....	58
4.2.1	Clinical evaluation (Studies I, III, IV and V).....	58
4.2.2	Components used and surgical technique.....	59
4.2.3	Screening protocol (Studies IV and V).....	61
4.2.4	Radiographic evaluation.....	61
4.2.4.1	Studies I, IV and V.....	61
4.2.4.2	Study II.....	64
4.2.5	Whole blood metal ion analysis.....	68
4.2.6	Cross-sectional imaging.....	69
4.3	Statistical methods.....	69
4.4	Ethical considerations.....	74
5	Results.....	75
5.1	Studies I and V.....	75
5.1.1	Cumulative survival and revisions of patients operated on with BHRs... ..	75
5.1.2	Clinical results.....	77
5.1.3	Radiographic analyses.....	78
5.1.4	Cross-sectional imaging.....	80
5.1.5	Male patients with femoral diameter of 50 mm or greater.....	83
5.2	Study II.....	85
5.2.1	Intra-observer results.....	85
5.2.2	Inter-observer results.....	85
5.3	Study III.....	87
5.3.1	Cumulative survival and revisions.....	87
5.3.2	Clinical results.....	91
5.4	Study IV.....	92
5.4.1	Cumulative survival and revisions.....	92
5.4.2	Risk factors for ARMeD.....	94
5.4.3	Clinical results.....	96
6	Discussion.....	98
6.1	Assessment of cup orientation.....	98
6.1.1	Inaccuracies with plain radiographs.....	98
6.1.2	Usefulness of assessment based on plain radiographs.....	99
6.2	Birmingham Hip Resurfacing.....	100
6.2.1	Aetiology of failure.....	100
6.2.2	Cumulative survival.....	101
6.2.3	Routine metal ion measurement.....	103
6.2.4	Limitations.....	103
6.3	HR in patients aged 40 or less.....	104
6.3.1	THA versus HR.....	104

6.3.2	Cumulative survival and revisions	104
6.3.3	Clinical outcome and quality of life.....	105
6.3.4	Activity and survival.....	105
6.3.5	Limitations.....	106
6.4	ARMeD with patients operated on with ASR hip replacement	107
6.4.1	Prevalence and risk factors	107
6.4.2	Limitations.....	108
7	Conclusions.....	110
	Acknowledgements	112
	References	114
	Original publications.....	129

1 Introduction

The choice of optimal bearing material in total hip replacement (THR) has been at the centre of investigation for almost a century (Santavirta et al. 2003). Each material, either metal, ceramic or polyethylene (PE) each has its unique characteristics regarding wear and performance under stress conditions (Santavirta et al. 2003). Due to its hardness metal alloy has been tempting choice for bearings to use in hip replacements. Cobalt-chrome (CoCr) alloy bearings were mainly used before the triumph of the metal-on-polyethylene (MoP) bearing couple beginning in the mid-1960s (Amstutz and Grigoris 1996). Early designs utilizing all-metal bearings had a number of issues of which very hard machining, manufacturing and inadequate surface finish were not the least (Wilson and Scales 1970, Amstutz and Grigoris 1996, Clarke et al. 2005).

The use of metal-on-metal (MoM) bearings surged in the late 90's and early 2000's. Advances in metallurgy and tribology made it possible to manufacture more precise and adequate metal components than earlier (Grigoris et al. 2006). Moreover the possibility to overcome the problems seen in the past with CoCr alloy bearings was deemed especially intriguing in the field of hip resurfacing (HR) or surface replacement since resurfacing of the femoral head requires the use of thin acetabular cups in order to utilize large diameter femoral components. The first modern MoM HR was introduced in 1996 by Derek McMinn (McMinn et al. 1996).

HR has several proposed advantages. Large femoral diameter has been claimed to preserve hip biomechanics enabling a better range of motion (ROM) and stability. Due to preservation of the femoral head revision to THR is thought to be straightforward and comparable to primary THR. And most importantly hard-on-hard bearings were reported to have extremely low wear, thus extending the lifetime of implants beyond 15-20 years (Anissian et al. 1999, Clarke et al. 2000, Clarke et al. 2005). Due to these theoretical advantages MoM HR became popular for young and active patients. Short term results were excellent as regards implant survival rate and clinical outcome (McMinn et al. 1996, Schmalzried et al. 1996, Daniel et al. 2004, Back et al. 2005). The alleged advantages were not, however,

explicitly proven since even to date there is a lack of randomized controlled trials comparing HR with small diameter THR.

In recent years there has been a rapid decrease in the use of large-diameter (LD) MoM bearings due to a high prevalence of adverse reaction to metal debris (ARMeD) (AOANJRR 2013). ALTR (adverse local tissue reaction) is a synonym for ARMeD and is commonly used in the North American literature (Amstutz 2011). The prevalence of ARMeD has been as high as 30% in some patients although prevalence is heavily dependent on the device used (Carrothers et al. 2010, Langton et al. 2011a, Langton et al. 2011b). Most importantly, ARMeD may cause severe soft tissue destruction affecting the outcome of revision operation if not diagnosed early (Grammatopolous et al. 2009).

The current state of MoM HR is unknown. LD MoM bearings used with THR are no longer acceptable as implants since these devices have failed in a large proportion of patients regardless of the design used (Langton et al. 2011b, Bosker et al. 2012, AOANJRR 2013, Jack et al. 2013). An especially frequent failure pattern has been corrosion and damage in the taper-trunnion resulting in large amounts of metal debris and elevated cobalt and chrome metal ion levels in whole blood (Lavigne et al. 2011a, Matthies et al. 2013). Wear debris originating from the taper junction is potentially more cytotoxic than bearing wear debris causing ARMeD (Matthies et al. 2013). However, HR has inevitable advantages over small-diameter THR in young and active patients. Hence intensive study must be undertaken in order to unequivocally identify the true prevalence of ARMeD, factors associated with the development of ARMeD and to assess the long-term results of HR. Some authors still believe that HR remains a viable option for carefully selected patients of young age and with high activity levels (Coulter et al. 2012, Holland et al. 2012, Murray et al. 2012). Patient lifetime is most likely to exceed implant life time in these patients and therefore they are likely to require revision at some point regardless of the superiority of the implant used. If we are truly discontinuing the use of a design that addresses several issues related to the demands of young patients, the decision must be taken mindful of the inevitable results regarding pros and cons.

2 Review of the literature

2.1 Evolution of metal-on-metal bearings

Treatment of joint destruction by using artificial materials has tempted surgeons since the late 1800's (Gomez and Morcuende 2005). Philip Wiles was the first to utilize the concept of THR in 1938 by replacing both femoral and acetabular side of the hip joint using bearings made from stainless steel (Wiles 1958). Until then the concept of hip replacement consisted of a primitive cup implanted in the head of the femur. The first of its kind in glass was implanted in 1923 in Boston, USA (Smith-Petersen 1948).

The first time CoCr alloy was used in the treatment of hip joint destruction was in 1938, when Smith-Petersen had implanted his own monoblock surfacing implant made from CoCr alloy (Smith-Petersen 1948). Satisfactory results among 500 mould arthroplasties were achieved in the majority of cases (Smith-Petersen 1948). The next milestone was the utilization of CoCr alloy in the bearing surfaces. In 1956 a British surgeon McKee developed his own acetabular component made from CoCr alloy which he coupled with a Thompson femoral component previously used in hemiarthroplasties in the USA (McKee 1970). The previous implant McKee had used in 1951 was made from stainless steel. The preliminary results with the McKee prosthesis were not satisfactory owing to only 54% success (McKee 1970). Survival was greatly increased after McKee started using cement for fixation (McKee 1970).

In the 1960's several THRs made from CoCr alloy were developed and used. The main differences between them were in the fixation method and in the geometry of the components. The British surgeon Watson-Farrar used the prosthesis developed by McKee in 1966 but Watson-Farrar modified the femoral stem by reducing the diameter of the neck, thus allowing greater ROM until component impingement (McKee and Watson-Farrar 1966). Two years earlier Peter Ring had developed his own THR which resembled that used by McKee and Watson-Farrar (Ring 1970). Instead of cement fixation in the acetabular side he used a long screw which was implanted into the iliopubic bar.

In the United States several combinations of cup and stem were used. Namely the Thompson or Moore femoral prosthesis was coupled with a matching socket

being either Urist or McBride label (Breck 1970, Debeyre and Goutallier 1970, Lunceford 1970). Each bearing couple was made from CoCr.

In United States several combinations of cup and stem was used. Namely Thompson or Moore femoral prosthesis was coupled with matching socket being either Urist or McBride label (Breck 1970, Debeyre and Goutallier 1970, Lunceford 1970). Each bearing couple was made from CoCr.

In 1963 the British surgeons Wilson and Scales also used cementless fixation in the acetabular side but replaced the single long screw with three smaller ones (Duff-Barclay et al. 1966). There was also a major difference in the geometry in the cup since they used a concave bearing surface instead of a circular contour. They assumed that the concavity of the acetabular side would allow better ingress of synovial fluid between the bearing surfaces (Duff-Barclay et al. 1966).

Development of MoM THR was also pursued in the Soviet Union. Sivash developed his own implant in which the femoral component was constrained inside the cup thus preventing dislocation of the stem (Sivash 1969).

The invention of the concept of modern THR has been attributed to the British Sir John Charnley. In the early 1960's he developed his own THR which consisted of a femoral component made of stainless steel coupled with a PE cup component fixed with bone cement (Charnley 1961). A major advance in his THR was the invention of bone cement and the idea of low friction torque by using femoral diameter of only 22.225 mm. Femoral diameter was significantly greater in the THRs used by McKee, Watson-Farrar, Ring and Wilson and Scales.

The results of MoM THRs were mainly poor (Amstutz and Grigoris 1996). This was predominantly due to loosening of the components, which resulted from higher friction within the bearing couple leading to cement-bone debonding (Wilson and Scales 1970). This in combination with the excellent results seen with the Charnley THR led to the abandonment of MoM bearings (Amstutz and Grigoris 1996).

MoM bearings became a subject of renewed interest in the late 1980's (Grigoris et al. 2006). Most importantly this was due to advances in tribology and metallurgy. Forging as a manufacturing process and high carbon content of the CoCr alloy enabled more precise surface polishing, which in turn reduced friction in the bearings (Wilson and Scales 1970).

The first THRs utilizing the new CoCr alloy, called Metasul, were implanted in 1988 by a Swiss surgeon, Weber (Santavirta et al. 2003, Grigoris et al. 2006). The availability of a new, low wearing CoCr alloy inspired several surgeon-inventors to

develop second generation HRs, McMinn in the UK and Wagner in Germany being the first (McMinn 1996).

2.2 Evolution of metal-on-metal hip resurfacing

The concept of HR dates back to the late 1800's (Gomez and Morcuende 2005). The very first surgical procedures and interventions developed for the treatment of destruction of joint surfaces were basically some form of resurfacings of the femoral head. It was logical to replace the destroyed joint surface of the femoral head. Smith-Petersen was the first to use artificial material for the resurfacing instead of allografts such as skin (Smith-Petersen 1948). He tried several different glass and plastic compounds. The most suitable material, however, was CoCr alloy, which had been widely used in dentistry at that time. Metallic monoblock resurfacing component was not fixed to the femoral head (Smith-Petersen 1948).

In the footsteps of Smith-Petersen and Judet Sir John Charnley also tried to develop a resurfacing hip replacement before his breakthrough in THR (Charnley 1961). In 1951, he was the first to implant a total HR replacing both femoral and acetabular sides of the hip. He used Teflon (polytetrafluoroethylene) in that resurfacing implant and both components were fixed without bone cement (Charnley 1961). Poor results due to osteonecrosis prompted him to use a large-headed stemmed femoral prosthesis made from stainless steel. Later on he applied the concept of low friction arthroplasty by using the smallest possible diameter in the femoral head, thereby increasing the difference in the radiuses of femoral head and socket (Charnley 1961).

Two years later in the USA, Haboush developed his own HR device which was made of a CoCr alloy and both components were fixed with bone cement.

Another American surgeon, Townley, developed his own version of an HR device, in which the femoral component was made of CoCr and the acetabular component of polyurethane. The first TARA (total articular replacement arthroplasty) was implanted in 1960 (Townley 1982). Very poor results were seen in the acetabular side as with other polyurethane devices. The metal cup became available in 1962. Later on, in 1977, PE was also applied to the bearing material in the acetabular component (Townley 1982, Pritchett 2008).

Throughout the 1960s, no significant developments were seen in the field of HR replacements due to the triumph of the Charnley THR. In 1967, however, the Swiss surgeon Muller designed a MoM HR implant which yielded excellent short

term results, at least when compared to the earlier designs using other bearing couples. Despite this, he abandoned the use of his device in favour of the Charnley THR (Freeman 1978).

In the early 1970s, various resurfacing concepts were developed all around Europe and in Japan. What most of these new designs had in common was the adaptation of PE which had yielded excellent results in Charnley THR.

In 1970, a French surgeon, Gerard, combined two previously developed acetabular cups, namely the Luck and Aufranc cups, to create his own resurfacing implant. Neither of the cups was fixed, thus making the implant “self centering” (Gerard 1978). Following device had a PE acetabular cup which wore away rapidly. The last and most successful device developed in 1975 by Gerard had two metallic cups with PE liner in the acetabular side (Gerard 1978).

In 1971, in Italy, Paltrinieri and Trentani designed a resurfacing replacement in which a femoral component made of stainless steel was coupled with a PE cup (Trentani and Vaccarino 1978). At the same time, a Japanese surgeon, Furuya, used the same materials but in reverse (Furuya et al. 1978). However, the preliminary results were not encouraging poor and Furuya and co-workers reversed the bearing materials.

A combination of a metal femoral head and a PE cup was used by Freeman in England, Amstutz in the USA, Tanaka and Nishio in Japan and Wagner in Germany. The fundamental idea of Freeman and co-workers was to “develop a method by which the hip could be replaced without the disadvantages of a stemmed femoral component” (Freeman et al. 1978). The first ICLH (Imperial College London Hospital) prosthesis was implanted in 1972. Both components had a cement fixation (Freeman et al. 1978).

Amstutz of the USA was the main surgeon inventor of the THARIES (total hip replacement by internal eccentric shells) procedure (Amstutz et al. 1978). The development was based on 1) a reproducible technique for minimal femoral head remodelling, 2) a range of components providing interchangeability and custom fitting abilities, 3) components positioning based on native hip anatomy and 4) a transtrochanteric approach (Amstutz et al. 1978). Again, both components had cement fixation.

In Japan development advanced through two surgeon-inventors between 1971 and 1976. Tanaka used stainless steel femoral heads coupled with PE acetabular components. The socket was eccentric having a thicker wall in the lateral weight bearing portion (Tanaka 1978). Nishio of Japan first used MoM double cup hip arthroplasty. The acetabular component was that of Urist and the femoral side was

his own design (Nishio et al. 1978). Later on, he used a PE lined CoCr acetabular cup.

In 1976 an Austrian surgeon (Salzer) introduced an HR device with ceramic bearings (Salzer et al. 1978). MoP resurfacings were still used in the early 1980's (Grigoris et al. 2006). Cemented cups had been abandoned in favour of metal backed porous coated ones with a PE liner introduced by Amstutz and Capello in USA (Grigoris et al. 2006).

The results of metal-on-PE HRs were not encouraging. The revision rates for the Wagner prosthesis, THARIES, TARA and ICLH were unacceptably high (Cotella et al. 1990, Freeman and Bradley 1983, Howie et al. 1990, Nesse 1991, Pritchett 2008). It is reasonable to assume that other devices share the same aetiology of failure since they all utilize the concept of a large diameter metal ball coupled with a thin PE shell. The majority of failures were due to aseptic loosening in both femoral and acetabular side. A major contributor to loosening was wear-induced osteolysis (Mai et al. 1996). Interestingly, John Charnley, advocate of small diameter metal-on-PE THR, stated as early as in 1970: "I distrust thin plastic sockets with large diameter steel heads. Elastic deformation under load with a thin socket may disturb the cement bond." (Charnley 1970)

Small patient series treated by Salzer with all ceramic HR did not succeed either owing to several cases of aseptic loosening (Salzer et al. 1978).

The introduction of new, low wearing CoCr alloy encouraged several surgeons to develop next generation HRs. The very first modern HRs was introduced by Wanger in Germany in 1991. In that design, both components had cementless fixation. This device, however, did not attract much attention and no long-term results are available (Grigoris et al. 2006).

In 1991, McMinn began using an HR device that he had developed himself (McMinn et al. 1996). The first version of this device had uncemented fixation, non-hydroxyapatite (HA) coated in both components. Due to a high incidence of aseptic loosening of these components, HA coating was later applied to both components, with significantly superior results. For reasons not explicitly stated in his book *Modern Hip Resurfacing* (2009) McMinn started to fix both components with cement. The cemented femoral component achieved excellent short-term survivorship. The cemented acetabular component, however, still had a high failure rate because of loosening. McMinn returned to using a cementless cup with HA coating. Thus his final concept was a hybrid HR design. Some changes were still made regarding the metallurgy and manufacturing of the components. Double heat treatment of the cast CoCr alloy resulted in a higher osteolysis-induced rate of

failure and single heat treatment was selected as the ideal manufacturing method. Contemporary Birmingham Hip Resurfacing (BHR, Smith and Nephew, Warwick, UK) was introduced in 1997.

2.3 Cup orientation in THR and in HR

2.3.1 Assessment of cup orientation

2.3.1.1 Planar radiographs

Postoperative radiographs are an important tool in the routine follow-up of hip arthroplasties (McBride and Prakash 2011). In addition to qualitative analysis of postoperative radiographs, quantitative measurements may also yield important information regarding the performance of the prosthesis. Qualitative analysis of postoperative radiographs includes assessment of osteolysis, radiolucencies, sclerosis and cement mantles if present (McBride and Prakash 2011).

Quantitative measurements include assessment of leg length, eccentricity of the femoral head in PE cups and cup orientation, of which the last is the most common quantitative measurement (McBride and Prakash 2011). This includes lateral opening or acetabular inclination and version of the cup. Acetabular inclination can be measured straightforwardly from anteroposterior radiographs (Lewinnek et al. 1978, McBride and Prakash 2011). Version however is more complicated to measure.

Over the decades several papers have been published proposing various methods to measure cup orientation, mainly version, in the THR from plain radiographs without any specialized computer software. Most commonly anteroposterior radiographs have been used in the measurements (Visser and Konings 1981, Seradge et al. 1982, Ackland et al. 1986, Hassan et al. 1995, Fabeck et al. 1999, Pradhan 1999, Widmer 2004). When anteroposterior radiographs are used the assessment of version is based on various calculations with the aid of the ellipse formed by the cup opening. Cross-table, i.e. lateral, radiographs can also be used in the measurement (Yao et al. 1995).

Version is straightforward to calculate when all-PE cups are used since the metallic rim inside the cup is fully visualized. As Lewinnek et al. (1978) described, version is the inverse sin value of the ratio of the short and long axis of the ellipse formed by the cup opening. However, when metal backed PE cups are used the

calculation of version is more complicated. Nevertheless cup version can be readily assessed since when small diameter femoral components (<32mm) are used, the cup opening is visualized to a great extent. Hence with the help of different kinds of indirect measurements the long and short axes of the opening can be measured and version thus analysed (Ackland et al. 1986, Pradhan 1999, Widmer 2004). Assessment of version in LD MoM hip replacement is more complicated since the cup opening is visualized only minimally due to the large femoral ball. EBRA (Ein Bild Roentgen Analysis) software is a frequently used tool in published studies to assess cup orientation reliably when contemporary MoM bearings are used (Langton et al. 2010).

2.3.1.2 Computed tomography

Computed tomography (CT) based measurement of cup orientation has been used in several recent studies (Hart et al. 2011a, Hart et al. 2011b, Hart et al. 2012). When radiographs are used in the assessment the calculated version is referred to as planar or radiographic. In CT scans version is calculated against the anatomic reference plane, which in most studies is the frontal pelvic plane or the McKibbin plane (McKibbin 1970). It is formed by the anterior superior iliac spines and pubic bone. Version obtained using CT is referred to as anatomical version.

There is no consensus on the correct anatomical reference plane. In the study by Ghelman et al. (2009) the reference plane was formed by the posterior border of the distal sacrum and the posterior border of the ischium. Marx et al. (2006), Olicrona et al. (2004) and Kalteis et al. (2006) used the McKibbin plane as a reference. It is obvious that these two different planes are not parallel in the vast majority of population. Several authors have claimed that planar or radiographic anteversion is unreliable (Kalteis et al. 2006, Marx et al. 2006, Ghelman et al. 2009). In their studies planar versions have been compared to those obtained using CT scans. The differences between x-ray based version and CT based version have been remarkable, ranging from 0 to 36 degrees.

It is important, however, to understand that CT and plain radiographs offer different premises for the assessment of cup version. When the version is calculated with CT, it is calculated against a plane formed by anatomical landmarks and deemed true version. If this reference plane matches the coronal plane, in theory, there is no difference between measurements taken with CT or using plain or planar AP radiographs. However, if there is pelvic tilting, the McKibbin plane formed by the anterosuperior iliac spines and pubic symphysis is not parallel with the coronal plane (McKibbin 1970). This may lead to large differences between

acetabular versions obtained from plain radiographs and to measurements taken by CT (Haenle et al 2007). None of the studies comparing CT and plain radiographs have taken pelvic tilt into consideration.

2.3.2 Clinical significance of cup orientation

The very first reported postoperative complication in THR which is associated with cup orientation was the dislocation of the femoral head. Lewinnek and co-workers (1978) described a "safe zone" for acetabular orientation which was defined as inclination between 30 and 50 degrees and version between 5 and 25 degrees. Outside this zone hips had a 4.1 fold risk of dislocation compared to hips with acetabular orientation within the safe zone. Since then the "Lewinnek safe zone" has often been referred to as the optimal and targeted acetabular orientation.

The effect of cup orientation on hip ROM has been widely studied. Cup orientation, however, is only one factor among others possibly affecting hip ROM, and such factors include soft tissue restrictions, cup coverage, head-neck ratio, femoral version and use of elevated-rim liners (Malik et al. 2007). It is well shown in several studies that a poorly oriented cup component may cause reduced ROM due to neck-cup impingement if other aforementioned factors allow wide ROM (D'Lima et al. 2000, Kluess et al. 2008, Williams et al. 2009).

The rules regarding cup orientation and ROM are the same for both THRs and HRs (D'Lima et al. 2000, Williams et al. 2009). With constant acetabular inclination extreme version angle reduces the arc of extension allowing a greater range of flexion at the same time. With insufficient version the situation is the reverse. If version is kept constant a too horizontally oriented cup reduces the arc of flexion allowing a greater range of extension. Again, the situation is the opposite with a more vertically oriented cup.

In a dry bone study investigating ROM after contemporary HR most physiologic ROM was seen with an inclination of 50 degrees and version of 25 degrees (Williams et al. 2009). In another clinical study multivariate analysis including demographic variables and cup orientation, head-neck ratio, head-neck off-set ratio and neck diameter the only significant correlate of flexion was version (Malviya et al. 2010). This finding is in accordance with in vitro studies, although the clinical relevance of the results is debatable.

In large diameter MoM THRs and in HRs cup orientation has a great deal of importance. The single most important factor in which cup orientation exerts influence is the wear of the cup. According to current knowledge the inclination

angle is more clearly associated with wear than version (De Haan et al. 2008, De Smet et al. 2008, Hart et al. 2011a, Hart et al. 2011c, Langton et al. 2011). Both metal ion release and volumetric wear have been shown to correlate positively with increasing inclination angle (De Haan et al. 2008, De Smet et al. 2008, Matthies et al. 2011). Direct comparison of inclination angles between different LD MoM devices, however, is not feasible. There are significant differences in the functional arc (FA) or cup articular arc angles (CAAA) between contemporary LD-MoM cups (Griffinet al. 2010, Jeffers et al. 2009). Smaller FA or CAAA leads to reduced cup coverage with equal inclination angle. Cup coverage on the other hand is the most important factor associated with cup wear (Underwood et al. 2011).

With optimal cup coverage there is no head-rim contact and the contact area between head and cup does not intersect with the rim of the cup (Underwood et al. 2011). It has been suggested that under this condition an optimal lubrication regime exists between the bearing surfaces and no relevant contact is present, thus leading to minimal wear. However, with decreasing cup coverage the contact area or contact patch of the head intersects with the rim of the cup and edge-loading is seen (Underwood et al. 2011). When edge-loading is present the lubrication regime is lost and adverse wearing properties are present leading to significantly increased wear (Catelas and Wimmer 2011). In several studies the presence of edge-loading has been associated with adverse soft tissue reactions and elevated metal ion levels (Kwon et al. 2010, Matthies et al. 2011).

2.4 Results of metal-on-metal hip resurfacing

2.4.1 Survival of HR

Survival after BHR has been favourable according to national hip arthroplasty registers. According to the Swedish Hip Register survival of BHR acetabular and femoral components was 98.2% and 95.6% at ten years respectively (SHAR 2013). according to the Australian registry, the cumulative revision rate of BHR was 7.1% at ten years (AOANJRR 2013). In the National Joint Registry of England and Wales BHR has shown a cumulative revision rate of 8.1% at nine years (NJR 2013).

Survival rates from BHR have been reported from many centres. In several papers, the combined survivorship after BHR has been reported to remain well above 95% at five to nine years in both male and female patients (Table 1). Madhu et al. (2011), however, reported a clearly inferior survivorship (91.5%) at seven

years compared to other studies. The authors did not report the survival rates separately for sexes. Even poorer survivorship was reported by Bisschop and co-workers (2013), namely 87.5% at five years. They performed systematic screening for pseudotumours (PTs) which may partly explain their results. To date, their study is the only one in which all BHR patients underwent cross-sectional imaging to find ARMeD.

There is a considerable variation in overall survivorship from BHR at ten years (Table 1). The highest survival rates have been reported in designer series (McMinn 2011, Matharu et al. 2013). There are three reports from independent centres (Table 1). Murray et al. (2012) performed cross-sectional imaging in patients with poor clinical outcome and 26 of the 54 revisions in their study were due to pseudotumours. Coulter et al. (2012) reported 11 revisions, of which only two were due to unexplained pain and one due to elevated metal ion levels. In the study by Holland and co-workers (2012), two of the eight revisions were due to ARMeD. Systematic imaging was not performed in the two latter independent series.

Study	Patients (hips)	Survival					
		5 years (95% CI)	6 years (95% CI)	7 years (95% CI)	8 years (95% CI)	9 years (95% CI)	10 years (95% CI)
Nishi et al. 2007	41 (46)	96% (91%-101%)					
Bisschop et al. 2013	129 (149)	87.5% (nr)					
Ollivere et al. 2009	463 (463)	95.8% (94.1%-96.8%)					
Heilpern et al. 2008	98 (110)		96.3% (92.8%-99.8%)				
Bose et al. 2010	71 (96)		95.4% (90%-100%)				
Madhu et al. 2011	101 (117)			91.5% (85.4%-97.6%)			
Aulakh et al. 2010	97 (101)*			95.0% (nr)			
Khan et al. 2009	653 (679)				95.7% (nr)		
McBryde et al. 2010	1826 (2123)				95.5% (92.1%-97.1%)		
Rahman et al. 2010	302 (329)					96.5% (94.7%-98.4%)	
Murray et al. 2012	554 (646)						87.1% (83.0%-91.2%)
Holland et al. 2012	90 (100)						92% (86.7%-97.3%)
Matharu et al. 2013	393** (447)						96.3% (93.7%-98.3%)
Coulter et al. 2012	213 (230)						94.5% (90.1%-96.9%)
McMinn 2011	nr (3095)	99% (nr)					97% (nr)

Table 1. Studies reporting survivorship of BHR using the Kaplan-Meier method. * OA group reported. ** Patients aged <50 years. nr = not reported.

BHR has been the most commonly used device in the majority of published studies reporting the results of HRs. Review studies reporting on the proportion of HR among BHRs has been 43.8%-44.8% (van der Weegen et al. 2011, Pailhe et al. 2012).

In addition to BHR, ten-year survival rates are available for Cormet (Corin Group, Cirencester, UK) and Conserve+ (Wright Medical Tech, Memphis, TN, USA) implants (Gross et al. 2012). Early version of the Cormet HR device, in which both components had uncemented fixation, resulted in a very high failure rate (Gross and Liu 2008). A hybrid version of the Cormet with cemented femoral component has resulted in a survival rate of over 90% at ten years in one study (Gross et al. 2012). Survivorship after Cormet has been significantly poorer in register-based studies. In the Australian register, for instance, Cormet has a reported 7.5% revision rate at five years (AOANJRR 2013). In the National Joint Registry of England and Wales, the revision rate was as high as 10.38% at seven years (NJR 2013).

The results for Conserve+ HR have been rarely reported apart from information from the surgeon-inventor group. They have reported an overall survival of 88.5% at ten years (Amstutz et al. 2010). The authors claimed that survival was satisfactory. This survival rate does not, however, comply with the requirement set by NICE, which requires 90% survival at ten years. Langton et al. (2011a) reported a 99.1% survivorship for Conserve + with revision for ARMeD as the end-point, suggesting that edge-loading and wear related failures are apparently not a frequent problem with this design. This may be partly attributable to larger articular arc or hemisphericity compared to other designs (Griffin et al. 2010).

Durom HR (Zimmer, Warsaw, IN, USA) was recalled as early as in 2008 due to “inadequacies in surgical techniques and instruction” (Blanchard 2008). Clinically, Durom HR design showed a high rate of failure owing to aseptic loosening of the cup. In published patient series, the prevalence of cup loosening has ranged from 0% to 10.1% (Berton et al. 2010, Long et al. 2010, Naal et al. 2011, Leclercq et al. 2013, Li et al. 2013). Although some studies have reported a low prevalence of cup loosening, overall survivorship after Durom HR has been poor in clinical studies. According to the Australian register, Durom had a failure rate of 9.3% at nine years.

In two published series ReCap HR (Biomet, Warsaw, IN, USA) device has achieved a acceptable survival rate (Gross and Liu 2012a, van der Weegen et al.

2012). Survivorship has, however, varied widely in different registers. The five-year failure rate of 11.8% in the Australian register is almost twice as high as the failure rate of 5.96% in the National Joint Register of England and Wales (AOANJRR 2013, NJR 2013).

Articular surface replacement (ASR) (DePuy, Warsaw, IN, USA) has been reported to have achieved acceptable, but below average overall survival in two studies from single centres (Bergeron et al. 2009, Jameson et al. 2010). In the earliest study, the survival rate of ASR was 97.2% with a mean follow-up of 200 days (Siebel et al. 2006). As early as in 2008, however, the Australian National Joint Replacement Registry reported a “higher than anticipated” revision rate with ASR cup in their annual report (AOANJRR 2008). This finding was “re-identified” in the next year’s report (AOANJRR 2009). In 2010, ASR HR and ASR XL THR were reported to have higher than acceptable failure rates, mainly due to increased wear resulting in ARMeD (Langton et al. 2010a). In the same year, ASR hip replacement devices were recalled by the manufacturer.

The Adept HR device (MatOrtho, Surrey, UK) has also been widely used and is among the most implanted devices in England and Wales in addition to the aforementioned HR concepts (NJR 2013). In the Australian register in 2011 Adept was the fourth most implanted device (AOANJRR 2011). According to the registers Adept has achieved good overall survival at five years with a failure rate ranging from 2.7% to 4.4% (AOANJRR 2013, NJR 2013).

Study	Patients (hips)	Brand	Survival							
			2 years (95% CI)	3 years (95% CI)	4 years (95% CI)	5 years (95% CI)	6 years (95% CI)	7 years (95% CI)	10 years (95% CI)	11 years (95% CI)
Li et al. (2013)	111 (141)	DUROM		91.9% (nr)						
Leclercq et al. (2013)	580 (644)	DUROM				91.2% (87-94)				
Naal et al. (2011)	91 (100)	DUROM				88.2% (84.3-92.1)				
Amstutz et al. (2010a)	89 (100)	Conserve+				93.9% (86.9-97.2)			88.5% (80.2-93.5)	
Jameson et al. (2010)	192 (214)	ASR			93% (90-98)					
Bergeron et al. (2009)	209 (228)	ASR				94.8% (nr)				
Gross and Liu 2008	18 (20)	Cormet (uncemented)						78.9%		
Stulberg et al. (2008)	nr (1023)	Cormet (hybrid)	95.9% (nr)							
Gross et al. (2012b)	329 (373)	Cormet (hybrid)								93% (nr)
van der Weegen et al. (2012)	240 (280)	ReCap					93.5% (88.8-95.3)			
Gross and Liu (2012a)	653 (740)	ReCap						96.4% (nr)		

Table 2. Studies reporting survivorship of other brands than BHR using the Kaplan-Meier method. nr=not reported.

2.4.2 Clinical results of BHR

The Harris Hip Score (HHS) (Harris 1969) remains the most commonly used tool to assess clinical outcome in patients with BHR (Table 3). Mean HHS has varied widely according to different studies (Table 3). Most of these studies have reported mean values for clinical outcome scores (HHS, Oxford Hip Score, d'Aubigne Score) and for the University of California, Los Angeles (UCLA) activity score (Table). This, however, is inappropriate since these scores are not normally distributed being non-parametric and hence median values should be reported. A minority of studies has reported median values.

Temporal changes of outcome variables are available from three different centres (Table 4). Khan et al. (2009) reported decreasing values of HHS and proportion of extremely satisfied patients during eight-year follow-up. Similar findings regarding OHS were reported by Australian authors in three consecutive studies (Table 4; Melbourne group) (Back et al. 2005, Hing et al. 2007, Coulter et al. 2012). Interestingly, in their latest study with ten-year follow-up they did not report HHS. A surgeon-inventor group also reported decreasing OHS values (Table 4; Birmingham group) (Treacy et al. 2005, Treacy et al. 2011).

Differences in mean HHS and OHS values during a longitudinal follow-up have been small, around one point. It is important to note, however, that all scoring systems used to assess the clinical outcome of hip arthroplasty have a ceiling effect (Wamper et al. 2010, Paulsen et al. 2012). HHS in particular has been shown to have a higher than acceptable ceiling effect (Wamper et al. 2010). The ceiling effect is higher in patients with HR than in patients with THR. This means that a very high proportion of patients score the maximum score of 100 points in HHS. This shifts the median value toward the maximum score. Hence even a one point decline in the mean value indicates significant changes in the distribution of the hip scores. Occurrence of slight pain in previously painless hip drops the HHS by four points. Hypothetically, if all patients score 100 in HHS, a drop of one point in mean value indicates that one in four patients is beginning to experience mild pain, i.e. scoring 96 points. However, since the median value in HHS is rarely 100, a one point drop in the mean value indicates significant changes in the distribution of HHS values.

Study	Patients (hips)	Follow-up	UCLA	OHS	d'Aubigne score	HHS	WOMAC	Satisfaction	ROM
Nishii et al. (2007)	41 (46)	Min. 5 years	-	-	17.4*	-	-	44 satisfactory 2 unsatisfactory	-
De Smet et al. (2005)	236 (252)	Mean 2.8 years	-	-	17.68*	97.24*	-	-	F: 123°
Heilpern et al. (2007)	98 (110)	Mean 71 months	7.5*	44.6*	-	96.4*	-	89/94 satisfied	-
Madhu et al. (2011)	101 (117)	Mean 7 years	-	38.5*	14.5*	84.8*	-	-	F: 100°
Ollivere et al. (2010)	94 (104)	Mean 61 mo	-	-	-	90*	-	-	-
Whitehouse et al. (2013)	- (103)	Median 50 months	-	47	-	-	-	SAPS: 100	-
Rahman et al. (2010)	302 (329)	Min. 5 years	7.5*	44.1*	-	94.3*	-	-	-
Holland et al. (2012)	90 (100)	Mean 9.55 years	7	-	-	96	WOMAC pain: 5.0	-	-
Aulakh et al. (2010)	OA: 97 (101) ON: 95 (101)	OA: 7.3 years ON: 7.5 years	-	-	-	OA: 96* ON: 95*	-	-	-

Table 3. Clinical outcome scores in studies reporting results of BHR not reported in Table 4. * indicates mean value otherwise median value. WOMAC = Western Ontario and McMaster Universities Arthritis Index

Study center (publications)	Outcome	1 year	2 years	3 years	4 years	5 years	6 years	7 years	8 years	9 years	10 years
Oswestry (Khan et al. 2008)	HHS (median)	95	96	96	95	96	94	87	88	-	-
	Extremely pleased	85%	84%	81%	83%	81%	82%	80%	78%	-	-
Melbourne (Back et al. 2005, Hing et al. 2010, Coulter et al. 2012)	HHS (mean) Charnley A	-	-	97.7	-	96.7	-	-	-	-	-
	HHS (mean) Charnley B	-	-	99.4	-	96.6	-	-	-	-	-
	HHS (mean) Charnley C	-	-	85.5	-	90.1	-	-	-	-	-
	OHS (median)	-	-	46.5	-	45.8*	-	-	-	-	45.0
Birmingham (Treacy et al. 2005, Treacy et al. 2011)	Modified OHS**	-	-	-	-	2.1%	-	-	-	-	4.2%

Table 4. Temporal changes of outcome variables in BHR studies. * = Investigators reported significant decrease compared to three year result. ** = Percentage indicates proportion of best results, ie. the higher percentage, the poorer scores.

2.5 Proposed advantages of HR

2.5.1 Hip biomechanics

Since the femoral diameter of HR mimics the native femoral head diameter it has been proposed that HR restores the native biomechanics of the hip better than conventional THR.

Girard et al. (2006) randomized 120 patients undergoing total hip replacement to receive either DUROM HR or 28 mm MoM uncemented THR. Several biomechanical parameters were compared to those of the unaffected contralateral hip. HR restored the horizontal centre of rotation, femoral offset and leg-length equality significantly better than THR. However, when patients with Perthes' disease or dysplasia were compared, significant improvement was seen only in femoral offset.

In another study Loughhead et al. (2005) investigated the differences between unmatched groups of HR and THR and came to the opposite conclusion stating that hip biomechanics were more precisely restored with THR. Girard et al. (2006), however, concluded that the conclusion of Loughhead and co-workers (2005) was incorrect. In the study by Loughhead et al. (2005) less change in femoral offset was seen in the THR group but they also reported increased leg length discrepancy and more superomedial centre of rotation than in the contralateral hip in the THR group, possibly compensating the total change in off-set.

Herman et al. (2011) compared leg lengths and femoral offset between unmatched groups of HR, 28 mm conventional THR and LD-MoM THR. They concluded that HR restores hip biomechanics best. However, they also claimed that this is not solely due to larger femoral diameter since similar findings were not seen in the LD-MoM THR patients.

2.5.2 Revision to THR

The most important proposed advantage of HR is the retention of a well fixed cup component in case of femoral side failure. This is claimed to make the revision operation more straightforward. Since the bone stock on the femoral side is well preserved, the operation is said to resemble primary THR using LD implant.

Peri- and postoperative results of converting failed femoral components in HR have been reported by several authors. When compared to primary THR using

either MoP or LD MoM hip replacements no differences have been observed in respect to operating time, blood loss, complication rates or clinical outcome scores (Ball et al. 2007, Garrett et al. 2011, Desloges et al. 2012). It is important to note that in these studies, and always when HR is revised and the cup is left *in situ*, the resurfacing cup is coupled with a matching head component attached to a modular stem. In three recent papers LD MOM THR has been reported to lead to a high incidence of ARMeD as well as to an unacceptably high failure rate due to taper wear (Langton et al. 2011b, Bolland et al. 2011, Bosker et al. 2012). Moreover, register studies have reported high failure rates with modular LD MoM THRs regardless of implant type (AOANJRR 2013, NJR 2013). Therefore, revision of HR leaving the cup component *in situ* is no longer an acceptable procedure.

2.5.3 Range of motion

There is only one published RCT comparing postoperative ROM in HR and THR (Howie et al. 2005). In that study, Howie and co-workers (2005) compared an early version of the McMinn resurfacing device and a 26 mm MoP THR. They found no difference in ROM between the groups.

The findings of retrospective studies comparing ROM after HR and THR are controversial. Lavigne and co-workers (2011b) assessed postoperative ROM in patients who had received either HR, LD-THR or 28 mm THR. The greatest ROM was seen in patients with LD-THR. No difference was seen between patients with HR or a 28 mm THR. Equal ROMs were seen in another study comparing HR to MoM THR with femoral diameter ranging from 28 mm to 50 mm (Le Duff et al. 2009). In contrast to these observations, Vail et al. (2006) reported significantly better ROMs in patients with HR compared to those who had MoP THR with femoral head size ranging between 28 and 36 mm. These retrospective series are all potentially susceptible to selection bias.

Impingement free ROM after HR has been investigated in many cadaver and computerized studies. Several factors influence impingement free ROM including cup hemisphericity, inclination and version, seating depth of the cup and head-neck ratio, the latter being presumably the most important (Chandler et al. 1982, Vendittoli et al. 2007, Incavo et al. 2011). Post-operative head-neck ratio in HRs has been reported only in a clinical study where it ranged between 1.11 and 1.47 in the immediate postoperative radiographs (Grammatopoulos et al. 2010b). When the head-neck ratio was set at between 1.207 and 1.224 resurfaced hips had significantly inferior ROM at flexion compared to standard HR with 32 mm

femoral head in one CAD study (Klues et al. 2008). When THR was compared to HR in cadavers, the former restored ROM better and HR resulted in poorer flexion and internal rotation (Incavo et al. 2011).

2.5.4 Stability

Small jumping distance is the most important factor associated with risk of dislocation (Sari et al. 2009). Other factors include small head-neck ratio, small femoral diameter, suboptimal cup orientation and joint laxity (Sari et al. 2009). Contemporary LD MoM bearings have high jumping distance which in theory reduces the risk of dislocation (Figure 1).

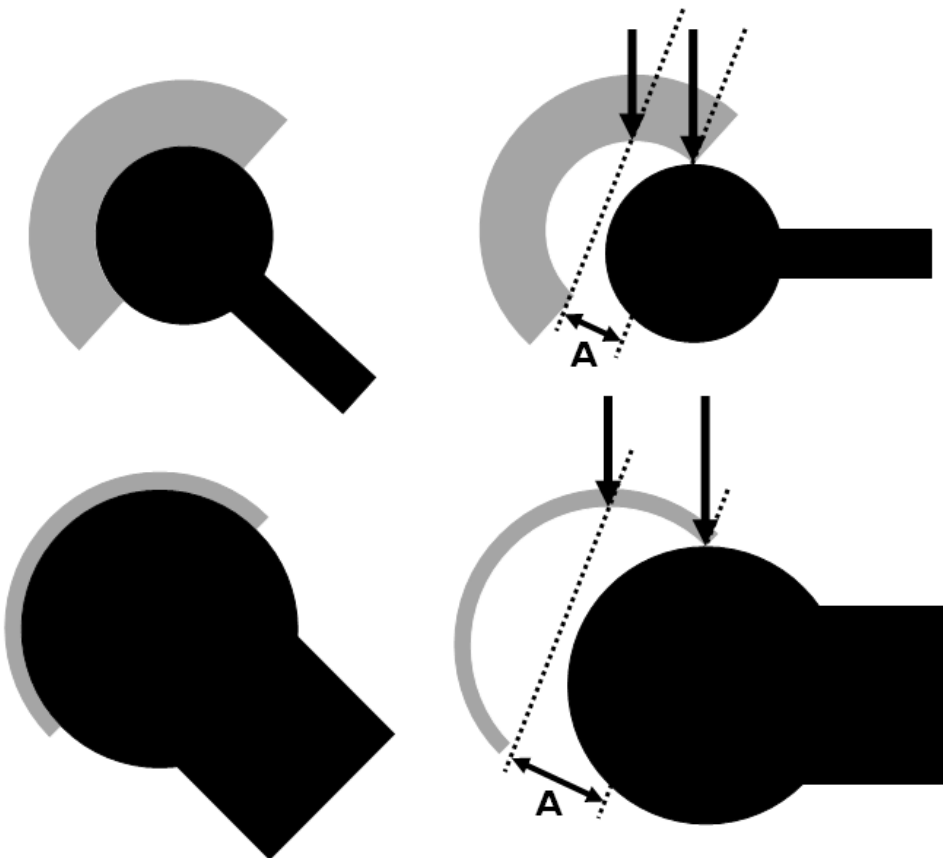

Figure 1. Upper schemas represent 28 mm THR and lower schemas represent 50 mm HR. Distance A indicates the distance the centre of rotation must transverse to dislocate. The distance is longer with larger diameter HR.

Numerous studies with minimum one-year follow-up and with different patient subcohorts and preoperative diagnoses have reported a 0% dislocation rate for HR (Daniel et al. 2004, McGrath et al. 2008, McMinn et al. 2008, Sayeed et al. 2010, Daniel et al. 2010, Berton et al. 2010, Bose and Baruah 2010, Jameson et al. 2010, Madhu et al. 2011, Holland et al. 2012, Kranz et al. 2012, van der Weegen et al. 2012, Li et al. 2013, Woon et al. 2013). Other studies have reported a 0.2 - 1.0% dislocation rate for HR (De Smet et al. 2005, Ollivere et al. 2009, Amstutz et al. 2010, Murray et al. 2012, Gros et al. 2012, Leclercq et al. 2013, Whitehouse et al. 2013). Some dislocations have occurred early in the postoperative period, and they have been treated with closed reduction. In some patients, however, dislocations have been recurrent, requiring revision surgery. In one study an overall dislocation rate of 3.1% was reported (Mont et al. 2007). This result was based on data obtained from the multi-centre Investigational Device Exemption trial using Conserve+ implant in an attempt to improve surgical technique.

2.5.5 Bone mineral density

Wolff's law states that in healthy persons bone will remodel i.e. strengthen under loading conditions. It has been amply demonstrated that in conventional THR bone mineral density decreases in the proximal femur around the stem and in the medial aspect of the cup (Venesmaa et al. 2003, Hayaishi et al. 2007, Penny et al. 2012, Smolders et al. 2013). This is thought to be induced by stress shielding, meaning decreased bone loading due to altered biomechanics.

Changes in bone mineral density (BMD) on the femoral side after HR have been studied intensively. It has been well established that BMD does not deteriorate after HR (Cordingley et al. 2010, Tapaninen 2012 et al. 2012, Malviya et al. 2013). Interestingly, in one study it was suggested that increased cup inclination was associated with better BMD preservation (Malviya et al. 2013). When compared to THR patients matched by several demographic variables, THR patients experienced a significant decrease in BMD, especially in the superolateral and inferomedial aspects of the femur (Kishida et al. 2004, Penny et al. 2012). Penny et al. (2012) reported a significant increase in BMD after HR in several femoral regions compared to preoperative values.

Contrary findings have been reported on the acetabular side. Although different periacetabular regional definitions have been used in these studies, a significant decrease in the BMD has been reported in the medial and superior periacetabular regions (Penny et al. 2012, Smolders et al. 2013). No change has been reported in

the inferior region. Penny et al. (2013) reported no differences in any of the regions compared to THR, whereas in the study by Smolders et al. (2013), patients with HR had higher BMD than those with THR in the medial and inferior regions, although BMD was still significantly inferior compared to baseline values.

2.6 Total hip replacement in patients younger than 40 years

2.6.1 Influence of age on the factors affecting the outcome of THR

With respect to preoperative diagnosis, younger patients undergoing THR differ greatly from older patients. Osteoarthritis (OA) is more frequently diagnosed in older patients. When looking at patients aged 50 years or less and patients aged 50 years or more, Amstutz et al. (2007) reported the prevalence of OA to be 86% among the older patients compared to 50% in younger patients undergoing HR. A more striking difference was seen in another study in which none of the patients aged less than 40 were diagnosed preoperatively with OA (Garcia-Rey 2009). Hip dysplasia, osteonecrosis (ON) and inflammatory arthritis are commonly seen indications for THR in younger patients (Furnes et al. 2001).

Preoperative diagnosis may have a significant effect on the outcome of THA. Hip dysplasia has been shown to be an independent risk factor for cup loosening in comparison to hips with OA (Bordini et al. 2007). Most importantly, cup fixation and positioning is more challenging in acetabular dysplasia due to insufficiencies in superior bony acetabular coverage (McMinn et al. 2008). HR patients with dysplasia have shown a significantly higher revision rate compared to OA patients in the Australian registry (AOANJRR 2013). Similar findings were reported for ceramic-on-ceramic THRs in patients aged less than 30 years (Garcia-Rey et al. 2009).

In their study comparing the results of HR in ON and OA patients, Gross and Liu (2012c) suggested that HR may not be suitable for ON patients. Their study included the largest reported cohort of ON hips (n=122) treated with HR. In other studies with smaller numbers of hips, the outcome of HR has been equally good in patients with ON as in patients with OA (Amstutz and Le Duff 2010, Aulakh et al. 2010, Sayeed et al. 2010). In the Australian registry, no difference was to be found in the revision rates of HR when patients with ON were compared to those with OA (AOANJRR 2013).

Younger patients undergoing THR are significantly more active than older patients (Amstutz et al. 2007, Lingard et al. 2009, Garcia-Rey et al. 2009). In THRs, PE wear and subsequent osteolysis are associated with the activity level of the patient rather than with time (Schmalzried et al. 2000, Lübberke et al. 2011). In several studies, young age *per se* has been established as an independent risk factor for acetabular revision in MoP THRs (Eskelinen et al. 2005, Bordini et al. 2007, Lazarinis et al. 2010).

One of the major advantages anticipated with the introduction of MoM bearings was the significantly lower wear compared to MoP articulations in laboratory tests (Schmalzried et al. 2000). This finding was thought to be of especial importance to young and active patients. Currently, the influence of activity on wear in MoM bearings is controversial, although published studies suggest increased metal ion release due to increased activity. Heisel et al. (2005) reported no significant correlation between patient activity and serum metal ion levels. In contrast to this, Khan et al. (2008) reported an exercise-related increase in cobalt (Co) levels. The rise was associated with the inclination angle. Moreover, a simulator study has shown that fast-jogging simulation led to a sevenfold increase in volumetric wear and a twentyfold increase in total wear particle surface area (Bowsher et al. 2006).

No studies have been published showing a correlation between intense patient activity and increased risk of pseudotumour (PT) or ARMeD in general. Glyn-Jones et al. (2009) reported that age under 40 years was an independent risk factor for PT formation in HR. They did not report patient activity.

Younger patients have less comorbidity than older patients (Lingard et al. 2009). Young patients also exhibit higher functional scores and better quality of life with respect to physical activity (Amstutz et al. 2007, Garcia-Rey et al. 2009, Lingard et al. 2009). In one study patients undergoing HR were significantly younger although the difference was not clinically significant (49.3 vs. 51.5) but nevertheless they had lower chronic disease score, higher Western Ontario and McMaster osteoarthritis index (WOMAC) score and better quality of life (MacKenzie et al. 2012).

All these factors impose high demands on HR in young patients, as do all other THR concepts. Patients with HR are more likely to return to sporting activities and this effect is more prevalent in younger patients with higher preoperative activity (Williams et al. 2012). Ghomrawi et al. (2011) reported similar recovery expectations in THR and HR patients matched for age, sex and activity, but interestingly HR patients had expectation of normal ROM independent of other higher levels activities.

The outcomes of THR in patients under age 40 have been reported in several studies. Bearings materials have varied widely in studies published since 2000 (Table 5). Both all-ceramic and all-metal bearings have shown good survival at seven to ten years. Nizard et al. (2008) reported significantly inferior survival with ceramic bearings compared to other studies. They attributed poor survival to the mode of acetabular fixation and anticipated better performance with improvements in fixation.

Fixation has mainly been achieved without cement on both sides. This is in accordance with the findings of Adelani et al. (2013), who reviewed all studies published between 1968 and 2008 performed on patients under the age of 30. Cemented fixation was used in 69.5% of cases implanted before year 1988. Only 22.7% of cases implanted after year 1988 had cemented fixation.

Study	Patients (hips)	Age limit (mean)	Implant type	Survival			
				5 years (95% CI)	7 years (95% CI)	10 years (95% CI)	15 years (95% CI)
Garcia-Rey et al. (2009)	56 (63)	40 (30.7)	Uncemented CoC		93.7% (86.7%–100%)		
Girard et al. (2010)	34 (47)	30 (25)	Uncemented (45/47) 28 mm (42/47) MoM			94.5% (80%-98.6%)	
Chiu et al. (2001)	50 (68)	40 (33)	Uncemented MoCP	98% (95%-100%)		67% (47%-88%)	
Nizard et al. (2008)	101 (132)	30 (23.4)	Uncemented (70/132) CoC			82.1% (72.4%-91.8%)	72.4% (57.2%-87.6%)
Busch et al. (2010)	48 (69)	30 (24.6)	Cemented MoP			83% (69%-92%)	
Duffy et al. (2001)	72 (82)	40 (32)	Uncemented MoCP	96.3% (92.2%-100%)		78.1% (69%-88%)	
Simon et al. (2011)	26 (34)	40 (28.3)	Hybrid MoCP (31/34)			95% (nr)	90% (nr)
Yoo et al. (2006)	61 (72)	40 (30)	Uncemented CoC			100% (nr)	

Table 5. Studies published since 2000 showing results of THA in patients under age 40. MoCP = metal-on-conventional polyethylene

2.6.2 Outcomes of HR in patients aged 40 years or less

Although HR is reportedly a favorable option in the treatment of isolated hip disease in young patients, there is a relative paucity in the literature regarding the results of HR in extremely young patients. To date outcome of HR in patients under the age 40 has been reported in four studies.

Seyler et al. (2009) analysed the results of HR in the US Food and Drug Administration investigational device exemption study. With a minimum follow-up of two years, patients under the age 35 had a failure rate of 14%. No information was presented regarding causes of failures or which type of prosthesis was used.

The results of HR in single-centre studies have been more encouraging. Sayeed et al. (2010) compared the outcome of HR and THR in patients under the age of 25 with ON. Both Conserve+ and Cormet 2000 devices were used, whereas the control group received a standard uncemented MoP THR. No differences were seen between groups in respect to survival or HHS. Both groups had a survival rate of 100% at seven years. In the HR group this can be considered very encouraging since all HR patients received small-headed ($\leq 50\text{mm}$) HRs, which are prone to increased wear.

The Conserve+ implant was also used in the study by Woon et al. (2013), who reported the outcome of HR in patients under age 30 operated on by the developer of the implant used. Six failures were seen among 46 hips. In five hips there was a loosening of either component and one hip was revised due to pain. Survivorship was 95% at eight years. Mean HHS was 87.8, which can be considered relatively poor compared to the results with BHR (Table 3). UCLA activity averaged 7.2 at latest follow-up.

The study by Krantz et al. (2012) also reported 100% survival with a mean follow-up of 51 months. Of the 24 hips in 22 patients 14 had been operated on with Conserve+ and ten with DUROM. Mean UCLA activity score was 7.6, which equals that reported by Woon et al. (2013). Mean HHS was 89.3, which is also relatively poor as in the study by Woon et al. (2013). Krantz et al. (2012) also reported that 21 out of 24 hips were pain free. This would suggest that the majority of patients have some disability which reduces the total HHS 10.7 points on average. These were not reported in that study.

2.7 Adverse reaction to metal debris

2.7.1 Historical aspects

The first reports on the toxic cardiovascular and renal effects of Co and chrome (Cr) date right back to the 1960's (McKenzie et al. 1973). In 1973 Coleman and co-authors (1973) reported elevated whole blood (WB) Co and Cr levels in patients with MoM THR. They were also the first to report anecdotally the metallic appearance of synovia and presence of perivascular inflammation in tissues around MoM THRs. The following year Evans and co-workers (1974) reported a possible association between metal hypersensitivity and loosening of MoM-THAs. In their study patients with loosened McKee-Farrar hip replacements showed a high incidence of metal hypersensitivity along with histological synovial necrosis. In the editorial section elsewhere in the same publication it was stated "Whatever one's views on the practical significance of this new evidence of metal sensitivity, we surely cannot ignore it" (Sweetnam 1974).

During the next 30 years in several reports metal hypersensitivity came to be associated with THR failure, especially with aseptic loosening (Hallab et al. 2001). In most studies the incidence of metal sensitivity was shown to be higher in patients with failed MoM THR than in patients with well functioning implant (Park et al. 2005, Korovessis et al. 2006). The causal effect of device failure and presence of metal hypersensitivity could not be demonstrated in these studies. The exact association of these two factors remains unknown (Hallab et al. 2001).

2.7.2 Risk factors

2.7.2.1 Wear and metal ion levels

The main risk factor for ARMeD is increased wear of the bearings (De Smet et al. 2008, Kwon et al. 2010, Langton et al. 2010a, Langton et al. 2011b). Since wear can be assessed only in revised implants not many studies have been published reporting correlation of wear and ARMeD.

Kwon et al. (2010) reported that eight hips revised due to PT had significantly higher linear wear rate than hips revised for other causes. Langton and co-workers (Langton et al. 2011b) reported volumetric wear rates using a co-ordinate measuring machine based on out-of-roundness traces of 57 ASR HRs revised due to ARMeD. Volumetric wear ranged between 2.30 mm³ and 95.5 mm³. They stated

that wear of all ASR hips exceeded “normal” volumetric wear rates. This was based on the baseline value for “normal” wear of 0.33 to 2.06 mm³ obtained from a cadaver study reporting wear rates of well functioning MoM THRs three to ten years *in situ* (Huber et al. 2010). This is significantly less than predicted by simulator studies. Clinical studies suggest 1.2 to 2.2 million gait cycles per year in typical arthroplasty patients (Sechriest et al. 2007, Kinkel et al. 2009). In simulator studies using HRs with 54 to 56 mm femoral diameter steady-state wear has been less than 0.5 mm³ per million cycles (Clarke et al. 2005). The product of these values results in higher volumetric wear than 2 mm³ in ten years.

High WB or serum Co and Cr levels indicate increased wear. Both WB and serum Cr and Co have been shown to correlate positively with linear and volumetric wear of the bearings (De Smet et al. 2008, Hart et al. 2011). Regardless of the HR design, patients with ARMeD have been shown to have significantly higher metal ion levels than patients with well functioning implant (Hart et al. 2009, Kwon et al. 2011, Langton et al. 2010a, Bisschop et al. 2013).

The significance of taper wear or damage for metal ion levels remains unknown. In a recent study volumetric wear of the taper did not affect the WB Co or Cr levels when wear of the bearing was included in the analysis (Matthies et al. 2013). Vundelinckx et al. (2013) studied serum metal ion levels in randomly selected 19 patients with ceramic-on-PE THR. Co level was above 5 ppb in six of the selected 19 patients. This highlights the importance of Co ions originating from the taper junction since this was the only MoM interface in their patients.

2.7.2.2 Acetabular inclination and version

High inclination is known to result in edge-loading and increased wear and metal ion release (De Haan et al. 2008, Langton et al. 2009, Hart 2011a, Hart 2011b). In the study by Langton et al. inclination angle was not associated independently with risk of ARMeD (Langton et al. 2010a). Significantly higher version, however, was seen in hips with ARMeD. Further, increasing incidence of ARMeD was seen with the combination of extremities of cup orientation in another study by same authors (Langton et al. 2011a). This was also seen in the study by Grammatopoulos et al. (2010). Contrary, Hart et al. (2011a) reported that version was negatively associated with Co and Cr levels, indicating that very high version should lead to reduced metal ion levels. Lastly, in a fourth study neither inclination nor version was associated with PT formation after HR (Matthies et al. 2012). Hence very small version or even retroversion is associated with increased

wear and elevated metal ion levels, whereas the implication of very high version remains controversial.

In a recent study Hart et al. (2012) reported an equal number of PTs in well-functioning MoM hip replacements and poorly functioning or revised hips. They were unable to find an association between acetabular component orientation and PT formation. All implants used in their study were HR and therefore taper damage and subsequent ion release was not a confounding factor. However, an important consideration is that the study conducted by Hart et al. (2012) was a case-control study, whereas the other studies reporting prevalence of ARMeD and PTs have been follow-up studies of a patient series (Grammatopoulos et al. 2010, Langton et al. 2011b). In summary, high inclination angle and the resulting reduced cup overage are a major risk factor for increased wear and development of ARMeD. However, it is not a necessarily risk factor for ARMeD, for it may be present in hips with optimal wearing conditions.

2.7.2.3 Femoral head diameter

In HRs small femoral head size (<50 mm) is a well established risk factor for ARMeD (Glyn-Jones et al. 2009, Langton et al. 2010). Smaller femoral sizes are have also been associated with increased metal ion levels (Langton et al. 2009, Desy et al. 2010). Articular surface or cup hemisphericity decreases with decreasing femoral head sizes in all other HR designs apart from Conserve+ (Griffin et al. 2010, Amstutz et al. 2011,). Therefore HRs with smaller femoral diameters are more prone to edge loading. Specifically this is due to reduced cup coverage when HRs with different femoral sizes and with equal inclination angles are compared. This is the leading cause of the higher failure rates seen in HRs with small femoral sizes.

In LD-MoM THRs the significance of femoral diameter is unclear. In two studies reporting high failure rate of ARMeD with contemporary LD-MoM THrs there was no difference in femoral diameter between failed and well-functioning hips (Bolland et al. 2011, Bosker et al. 2012). Langton et al. (2011b) even reported a higher prevalence of ARMeD in THRs with femoral diameter of 55 mm or more compared to THRs with femoral diameter between 49 and 53 mm.

2.7.2.4 Modularity

In a study using DUROM hip replacement patients with THR had significantly higher metal ion levels than patients with HR with identical bearing couple

(Garbuz et al. 2010). Taper damage has been associated with increased Co ion release (Cooper et al. 2013, Matthies et al. 2013, Vundelinckx et al. 2013). The exact mechanism of the damage is unknown. Both corrosion and mechanical wear have been proposed. Taper itself as a risk factor for ARMeD has not been studied in a multifactorial manner. In a recent study by Matthies et al. (2013) taper wear was not associated with increased metal ion release or PT formation when wear of the bearing surfaces was included in the analysis. However, reports on survival after ASR HR and ASR XL THR amply demonstrate the significance of taper in ARMeD development since these two devices have identical bearing systems (Langton et al. 2011b). Whether the ionic Co debris released from the taper is more toxic than the ions originating from bearing surfaces remains unknown.

2.7.2.5 Demographic variables

Acetabular orientation, head size and taper damage are all mechanical and implant related risk factors for ARMeD. The significance of demographic variables remains unknown. The influence of sex is the most controversial issue. Since the 1970's hypersensitivity has been reported to be a failure mechanism in some loosened MoM hip replacements. Since metal hypersensitivity or allergy is more prevalent among females, they have been proposed to be at increased risk of ARMeD due to patient susceptibility (Hallab et al. 2001).

Glyn-Jones and co-workers (2009) reported 39 PTs among 1,419 MoM HRs. Patients aged under 40 years and of female sex were associated with increased risk of PT formation. They did not include acetabular inclination in their multivariate analysis. Femoral diameter on the other hand was included and hence their results suggest that female patients may indeed be more prone to ARMeD, possibly due to aseptic lymphocyte-vasculitis associated lesions (ALVAL) or other inflammatory response. This is further supported by the fact that ARMeD may be present in patients with low wearing devices and high wear is not a necessary risk factor for ARMeD as reported by Matthies et al. (2012).

2.7.3 Histopathogenesis

Histological findings in hips with failed MoM THR have been reported by several authors (Willert et al. 2005, Davies et al. 2005, Natsu et al. 2012). Failed MoM THRs have had a specific histological appearance compared to other failed hips with different bearing couples and this tissue response has been termed lesion

ALVAL (Willert et al. 2005). This umbrella term includes four specific synovial findings.

In most failed MoM hips the synovial cell lining is missing and is replaced with fibrin exudation (Willert et al. 2005, Natu et al. 2012). In some cases extensive cellular necrosis may be seen. In the study by Davies et al. synovial destruction was more prevalent in MoM hips revised due to aseptic loosening than in MoM hips revised for other reasons (Davies et al. 2005).

Inflammatory cell response is variable. The main finding which is also reportedly a hallmark of ALVAL is perivascular infiltration or accumulation of lymphocytes (Natu et al. 2012, Watters et al. 2010). Moreover these cuffs are seen in postcapillary venules (Willert et al. 2005). The main cell type is CD3-T-lymphocytes. Small amounts of B-lymphocytes have also been seen (Willert et al. 2005). In some cases lymphocytes have been present as germinal centres.

Debris-laden macrophages are usually present to some extent. Foreign body reaction in hips with ALVAL, however, has been described as mild (Davies et al. 2005, Willert et al. 2005). One specific feature in MoM implants has been the presence of plasma cells adjacent to macrophages (Willert et al. 2005). Campbell et al. proposed an ALVAL score to estimate the degree of ALVAL-type response. Three subclasses included assessment of synovial lining, inflammatory infiltration (lymphocyte-dominated versus macrophage-dominated) and tissue organization (Campbell et al. 2010).

ALVAL-scores in failed MoM hips have been described in some studies. It is also known that perivascular lymphocytes are not a pathognomic finding in hips with PT (Hart et al. 2012). A correlation between high wear and macrophage infiltration has been proposed (Campbell et al. 2010, Grammatopoulos et al. 2013). Furthermore, dominant lymphocyte infiltration has been associated with hips with suspected hypersensitivity and low wear (Campbell et al. 2010, Grammatopoulos et al. 2013). However, opposite results have been reported. Lohman et al. (2013) reported higher tissue metal content in hips with lymphocyte dominated response than in hips with a more macrophage dominated reaction. The association of histological findings with specific PT characteristics i.e. cystic and atypical fluid lesions remains unknown.

2.7.4 Systemic exposure to metal ions

It is well known that metal ions originating from MoM devices are secreted and measurable in blood. Consequently in theory Cr and Co ions may have systemic

effects. Concern about the potential carcinogenicity of these ions has been a subject of investigation for several decades (Visuri et al. 1996, Makela et al. 2012, Brewster et al. 2013, Lalmohamed et al. 2013).

Both Cr and Co are essential metals for human metabolism (Dunstan et al. 2008). At the same time, Cr has been shown to have carcinogenic effects (Dunstan et al. 2008). The difference lies in the valence of the Cr ions. Cr³⁺ is the form of dietary Cr. In contrast the carcinogenic effect of Cr is due to Cr⁶⁺. It is still unclear which form of Cr is produced by MoM devices. In vivo studies have shown, however, that patients with MoM implants have chromosomal aberrations, i.e. abnormalities in their peripheral blood (Wagner et al. 2012).

Chromosomal aberrations and exposure to carcinogens naturally raise concerns about an increased risk of cancer. In several register and retrospective cohort studies patients with MoM hip implants have not evinced higher incidence of cancer in general (Mäkelä et al. 2012, Brewster et al. 2013, Hartmann et al. 2013, Lalmohamed et al. 2013). However, in a study based on Finnish national registers, Mäkelä and co-workers found that the risk of soft-tissue sarcoma and basalioma in the metal-on-metal cohort was higher than in the non-metal-on-metal cohort (Mäkelä et al. 2014).

2.7.5 Metal ion levels

One of the most significant features of MoM hip replacements is the measurable elevation of Co and Cr ions in blood and serum. The behaviour of Co and Cr in well functioning MoM HRs is well known. They first reach a peak level, Cr earlier, six to nine months after implantation, which is considered to be the running-in phase (Clarke et al. 2005, Daniel et al. 2009). After that a small decrease is seen and the metal ions level out, which is called the steady-state (Clarke et al. 2005, Daniel et al. 2009). The plateau stage has been shown to last at least six years and further changes are not known (Daniel et al. 2009). It has been suggested that after six to seven years metal ions have an upward trend (deSouza et al. 2010).

In the methods and measurements in early studies reporting postoperative metal ion levels have varied greatly. Concentration of metal ions in blood has been analysed from plasma, serum and WB (Hartmann et al. 2013). Different units for concentration have also been used. Concentration has been reported using nanomoles per litre (nmol/l), micrograms per litre (µg/l) and parts per billion (ppb) of which the latter two are interchangeable. Current consensus statements from the European Federation of National Associations of Orthopaedics and Traumatology

(EFORT), the European Hip Society (EHS), the German Arbeitsgemeinschaft Endoprothetik (AE) and the Deutsche Arthroshilfe (DAH) recommend using WB measurements and ppb as a reporting unit (Hannemann et al. 2013).

The statement mentioned above also includes a threshold value for “clinical concern” which ranges from 2 ppb to 7 ppb (Hannemann et al. 2013). Values less than 2 ppb are without “clinical concern”, and 7 ppb is also the cut-off value which the UK Medicine and Healthcare Regulation Agency uses as a trigger value for imaging (Medicines and Healthcare Products Regulation Agency 2012). The US Food and Drug Administration does not recommend metal ion analysis as a screening tool (US Food and Drug Administration 2013).

The optimal cut-off value for adverse soft tissue reaction has been investigated by several authors. When a positive magnetic resonance imaging (MRI) finding was used as a diagnosis for ARMeD, Malek and co-authors (2012) reported a sensitivity of 86% and specificity of 27% when using serum Co or Cr values of 3.5 ppb as a cut-off value. Specificity was quite poor but major bias arises from the fact that only PT was used as an end-point and hence many of the patients with Co or Cr values over 3.5 ppb might still present with an intracapsular ARMeD, which is not readily assessed in MRI. Malek and co-workers (2012) concluded that metal ion screening should not be used as a sole screening method, but in conjunction with clinical assessment and imaging.

Macnair et al. (2013) had a similar research frame with a smaller patient cohort. In their study, with 4 ppb as a cut-off value, sensitivity and specificity for Co were 72% and 66% and for Cr 61% and 66% respectively. Their final conclusion was that normal metal ion levels can be misleading and MRI is advisable in all patients.

Hart et al. used “true unexplained pain” as a cause for revision as an end-point for their analysis (Hart et al. 2011b). This indicated that all traditional reasons for implant failure (loosening, infection, malalignment, fracture, size mismatch) were ruled out leaving only presumed adverse soft tissue reaction as a cause for the unexplained postoperative pain. In their case-control study maximum Co or Cr of 4.97 ppb yielded a sensitivity of 63% and specificity of 86%, which are superior to those reported by Malek et al. (2012). A major difference between these studies was the definition of ARMeD, since the failures in the study by Hart et al. (2011b) included not only those with PT but also those with intracapsular ARMeD.OK

2.7.6 Cross-sectional imaging

2.7.6.1 Early reports

The very first report on cross-sectional imaging findings in ARMeD was published in 2006 by Boardman et al. (2006). They described “a solid, circumscribed heterogeneous lesion” around the BHR hip. Perioperative finding in the revision operation included synovitis and black staining of the femoral neck. Necrotic tissue and extensive lymphocytic infiltration was noted in the microscopic analysis of the synovia.

Another report followed in 2007 by Gruber and co-workers (2007), who identified periarticular soft tissue lesions with "sharp margins" and hyperintense core signal in two patients with MoM THR. Since then an increasing number of reports have been presented on adverse soft tissue reactions around MoM implants due to advances in imaging techniques.

2.7.6.2 MRI

The characteristics of MRI findings in PTs vary widely. Milder cases involve cystic lesions which present a typical fluid signal with thin walls. The cores of these lesions have hyperintense signal to skeletal muscle on T2W images and isointense on T1W images (Hauptfleisch et al. 2012, Sabah et al. 2011). In some cases the walls may be in apposition with only small amounts of fluid. This type of PT resembles typical bursa and such findings have also been reported around non-MoM implants (Carli et al. 2011). Cystic masses or lesions have been reported to be located mainly posterior to the hip joint (Hauptfleisch et al. 2012).

More severe PTs present with thicker walls. Content or core of the PT may appear fluid-like as mentioned earlier. In some cases the core may appear more heterogeneous with variable signal intensity in T2W images (Sabah et al. 2011, Hart et al. 2012). T1W images show hyperintense signal intensity. The shape of these PTs may also be irregular (Sabah et al. 2011, Hart et al. 2012).

The most severe PTs appear in MRI to be predominantly or totally solid (Hart et al. 2012). Wall and core cannot be differentiated. In several reports PTs with solid component have mostly been located anterior to the hip joint (Hauptfleisch et al. 2012). These PTs have been reported to be more symptomatic and require revision more often (Hauptfleisch et al. 2012).

To date several classification systems for PTs have been proposed. The imperial classification by Hart et al. (2012) and the classification proposed by Hauptfleisch

et al. (2012) have many similarities. In both systems type 1 PTs are cystic lesions with thin walls and typical fluid signal. Type III in both systems includes those PTs which are predominantly solid without apparent border or wall structure. Type II PTs in the Hauptfleisch classification are cystic lesions with thick walls, which is almost the same as Imperial IIa. Type IIb PTs in Imperial classification differs from IIa, the content being atypical fluid signal.

The Anderson classification, also including three classes, is different from the aforementioned since it does not identify lesions with hyperintense T2W signal indicating cystic masses (Anderson et al. 2011). Another difference is the relevance of the size of the PT, which is without importance in the Imperial and Hauptfleisch classifications.

Hayter classified extraarticular lesions as being either “synovitis” or “extracapsular disease” (Hayter et al. 2012). The former was used if the content of the PT or the lesions communicated with the joint and if it did not it was classified as “extracapsular disease”.

2.7.6.3 Ultrasonography

In addition to MRI, ultrasonography has also been used in the assessment of PTs seen around MoM implants (Kwon et al. 2011, Nishii et al. 2012). The findings are similar to those seen in MRI, ranging from cystic lesions with fluid content to irregularly shaped, thick walled ones with partially or totally solid content (Kwon et al. 2011). Kwon et al. (2011) also reported similar distribution of PTs as in the MRI. Cystic ones located predominantly at the posterior and more solid PTs located predominantly at the anterior aspect of the hip.

US has some advantages over MR imaging. Synovial changes cannot be reliably assessed in MRI sequences due to artefacts caused by the implant metal. Using US synovial hypertrophy or joint expansion can be readily assessed. No classification systems for PTs seen in US have been proposed in the published literature.

Neither of the imaging modalities has been shown to be superior to the other. Ultrasonography is less expensive and more easily accessible, but it is operator dependent as are all ultrasonography examinations. MRI with magnetic artefact reduction sequence (MARS) is far more expensive but it has superior imaging quality and patient related factors i.e. excessive subcutaneous fat does not limit its use. No studies have so far been published comparing these two imaging modalities.

2.7.7 Operative findings

Coleman and co-workers were the first to report that tissues around CoCr THR “often have a black appearance” (Coleman et al. 1973). Nowadays this finding is termed metallosis and is a frequent intraoperative macroscopic finding in hips which have been revised due to unexplained pain (Korovessis et al. 2006, De Smet et al. 2008, Ollivere et al. 2009, Browne et al. 2010). It is unknown whether high wear is a necessary factor for metallosis to develop or whether it may occur in low-wearing and well-fixed hips. In studies reporting macroscopic metallosis in failed MoM hips the cups have been mostly suboptimally oriented or loose (Korovessis et al. 2006, Ollivere et al. 2009).

In the study by Hayter et al. metallosis was present in nine hips out of a total of 20 revised due to PT (Hayter et al. 2012). Of these nine hips six had evidence of ALVAL in the PAD sample of the synovia. Of the remaining eleven hips without metallosis six had findings suggestive of ALVAL, indicating that histological diagnosis of ALVAL is not specifically associated with metallosis, which on the other hand is a macroscopic diagnosis.

In the same study five out of nine hips with metallosis also had macroscopic evidence of soft-tissue necrosis, but this was also seen without the presence of metallosis. This is in accordance with the findings of Toms et al. (2008), who observed soft-tissue necrosis in eight out of 15 hips revised due to PT. They did not report appearances of synovia.

In addition to metallosis, other synovial findings have rarely been described. Browne et al. reviewed intraoperative findings in ten patients who had undergone revision due to suspected ARMeD (Browne et al. 2010). Synovia was described as greenish or hypertrophic and in some cases the general term synovitis was used. The general term synovitis was also a common finding in a study by Liddle et al. (2013) describing findings in 39 failed MoM hips.

Browne and co-workers (2010) also stated that joint effusion was “universal” in hips with ARMeD. The appearance of the fluid has been described by several authors as milky. Browne et al. (2010) also reported dark fluid in some hips. Toms et al. (2008) described only fluid-filled cavities. The appearance of the fluid was not specified. They also reported periprosthetic soft tissue thickening or a soft tissue mass in each of the 15 revised symptomatic MoM hips. In eight cases there was also macroscopic necrosis.

Osteolysis is a frequent finding around each bearing type used in THAs. In MoP bearings it has been associated with increased wear. Osteolysis has also been reported in failed MoM hip replacements (Hayter et al. 2012, Liddle et al. 2013). It

remains unknown whether it is a wear-related phenomenon or more related to inflammatory response, i.e. ALVAL.

3 Aims of the present study

The main purpose of this study was to investigate the medium term results of metal-on-metal hip resurfacing and to establish risk factors for adverse reaction to metal debris in patients operated on with contemporary large-diameter metal-on-metal total hip replacement.

The specific aims of the studies were to investigate

- Study I: Cumulative survival and clinical outcome of Birmingham Hip Resurfacing after five to eight year follow-up
- Study II: Inter- and intraobserver reliability of a novel method to assess cup orientation in contemporary hip resurfacing
- Study III: Cumulative survival, clinical outcome and quality of life after contemporary hip resurfacing in patients aged 40 or less
- Study IV: Prevalence and risk factors for adverse reaction to metal debris in patients operated on with small headed articular surface replacement.
- Study V: Cumulative survival and prevalence of pseudotumours in patients operated on with Birmingham Hip Resurfacing and the usefulness of routine whole blood metal ion measurement

4 Patients and methods

4.1 Patients

BHRs were implanted in our institution between May 2001 and March 2012. For the purposes of Study I we identified all patients who had received BHR between May 2001 and May 2003. A total of 126 patients (144 hips) were identified and included in the study (Table 6). One hundred and seven patients (122 hips) attended our hospital for a follow-up examination at least once and none were lost to follow-up. Sixteen patients living outside of our hospital district did not attend for regular follow-up. Three patients moved abroad.

	Males	Females
Patients	82	44
Hips	92	52
Prosthesis		
Left-side	36	24
Right-side	36	12
Bilateral	10	8
Diagnosis		
OA	76	31
CDH	8	15
Fracture	0	4
Legg-Perthes	3	0
Caput necrosis	3	1
Other	2	1
Mean age	52.1 years	50.7 years
(Range, SD)	(22 to 71, 9.2)	(15 to 68, 9.0)
Preoper. HHS	52.2 years	50.7 years
(Range, SD)	(28 to 83, 18.3)	(24 to 83, 15.0)

Table 6. Demographic data of the first 126 BHR patients in Study I

For the purposes of Study II twenty hips were randomly selected from those included in Study I.

For the purposes of Study V we widened the patient selection by including all BHR patients operated on between May 2001 and May 2004 in the study. This yielded to total number of 219 patients (261 hips) (Table 7). Of these patients 18 were lost to follow-up, one had died and 14 had been revised prior to initiation of

the screening protocol. The remaining 191 patients were asked to participate in the screening protocol (Figure 2).

		Males	Females
Patients		149	70
Hips		177	84
Diagnosis	OA	143	57
	DDH	12	21
	ON	10	1
	Other	12	5
MoM device in contralateral hip	ASR	9	2
	ReCap	8	1
	Durom	2	0
	Other	5	4
Mean age (SD)		53.7 years (9.7)	53.6 years (7.8)

Table 7. Demographic data of the 219 BHR patients in Study V.

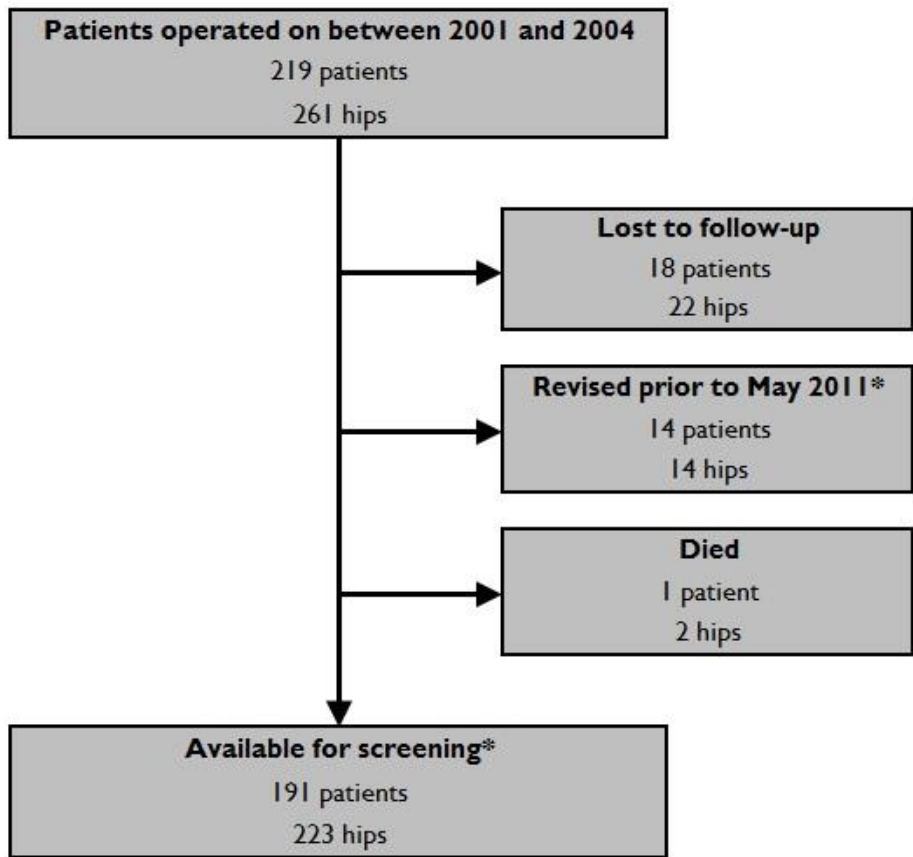

Figure 2. Flow-chart of Study V. *There were five patients with bilateral implants who had one hip revised prior to screening and the other hip was available for screening.

Between May 2001 and May 2008 a total of 1,092 HR arthroplasties were performed on 931 patients in our institution. Of these operations 75 were performed on 64 patients aged less than 40 at the time of the primary operation (Figure 3). These patients were included in Study III (Table 8).

	Males	Females
Patients	43	21
Hips	52	23
Diagnosis		
OA	24	6
ON	9	1
DDH	0	8
Other	8	8
Mean age	34.1 years	32.7 years
(Range, SD)	(17 to 40, 9.8)	(15 to 40, 11.6)
Mean Preop.	57.6	55.5
HHS	(28 to 85)	(34 to 73)
(Range)		
Comorbidities		
None	31	14
Mixed Connective Tissue Disease	1	0
Idiopathic thrombocytopenic purpura	1	0
Charcot–Marie–Tooth disease	0	1
Ankylosing spondylitis	0	1
Psoriatic arthritis	1	0
Juvenile idiopathic arthritis	1	0

Table 8. Demographic data of the 64 patients with HR aged less than 40 years included in Study III.

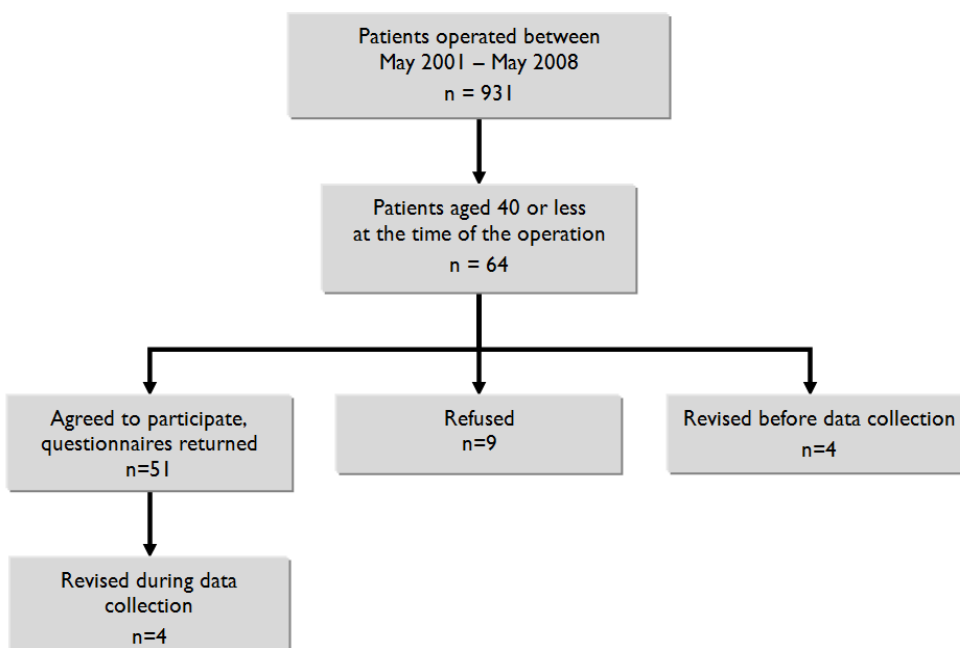

Figure 3. Flow-chart of Study III

One thousand and thirty-six ASR MoM hip arthroplasties were performed on 887 patients at our institution between March 2004 and December 2009. In 482 operations (424 patients), a femoral head size less than 50 mm was used (Table 9). These 424 patients were included in Study IV. One hundred and forty-two patients (168 hips) received an ASR HR prosthesis and 281 patients (312 hips) were implanted with an ASR XL THR prosthesis. One patient received both implants.

All 386 living patients (442 hips with a femoral head size less than 50 mm; one patient had bilateral implants—one revised before screening and one available for screening) who not having had revision surgery were asked to participate in a screening programme. Patients' demographics and radiological variables are shown in Table 9.

Demographic	Cohorts		p-value
	HR	THA	
Patients (number)	142	281	
Hips (number)	168	312	
Age (years)			
Mean (range)	53 (14-77)	58 (15-79)	< 0.001
< 50	43 (30%)	46 (16%)	
≥ 50	99 (70%)	235 (84%)	
Sex			
Male	125 (88%)	202 (73%)	< 0.001
Female	17 (12%)	74 (27%)	
Diagnosis			
Primary OA	137 (81%)	203 (65%)	< 0.001
Other	32 (19%)	110 (35%)	
Inclination			
Mean (range)	46.5° (29°-67°)	46.5° (28°-75°)	0.96
< 50°	125 (74%)	218 (70%)	
≥ 50°	44 (26%)	95 (30%)	
Preoperative ROM			
Mean (range)	156° (40°-275°)	140° (15°-270°)	< 0.001
< 130°	49 (30%)	121 (43%)	
≥ 130°	114 (70%)	158 (57%)	
Cup coverage			
Mean (range)	29° (9°-47°)	29° (0.9°-48°)	0.82
< 25°	36 (21%)	88 (28%)	
≥ 25°	133 (79%)	225 (72%)	

Table 9. Demographic and radiographic data of patients in Study IV. (One patient had both HR and THA, patient not shown in table).

4.2 Methods

4.2.1 Clinical evaluation (Studies I, III, IV and V)

All patients included in Studies I, III, IV and V and who attended our hospital for follow-up examination underwent a clinical examination using HHS (Harris 1969). HHS is a short patient reported outcome score (0 to 100) survey consisting of eight questions (pain, support, walking distance, limping, putting on shoes/socks, sitting, walking on stairs, use of public transport). Measurement of hip ROM is also included in the HHS. Patient satisfaction was also elicited on a scale 0-3 (0=poor, 1=fair, 2=good, 3=excellent).

Patients included in Study I and living outside our hospital district were sent a letter consisting of HHS without the motion part. Satisfaction and the possible indication for hip revision were also elicited. Follow-up radiographs of these patients were not available for analysis.

The RAND-36 quality of life and UCLA activity questionnaires were sent to all patients included in Study III (Amstutz et al. 1984, Hays et al. 1993). The RAND-36 questionnaire has eight health related domains: physical functioning, bodily pain, role limitations due to physical health problems, role limitations due to personal or emotional problems, emotional well-being, social functioning, energy/fatigue and general health perceptions. Each domain is scored from 0 (worst) to 100 (best). The UCLA activity is a one-question survey of activity scaled 1 (totally inactive) to 10 (impact sports regularly).

All patients participating in the screening protocol in Study IV received an OHS (scored 0-48) questionnaire by post (Dawson et al. 1996). The OHS is a 12-question survey on hip related pain, mobility and limitations during the last four weeks.

4.2.2 Components used and surgical technique

In Study I all patients had received a BHR implant. Median femoral component diameter in female patients was 46 mm (42 mm to 52 mm) and in male patients 54 mm (48 mm to 60 mm).

In Study III three different HR devices were used: BHR in 26 patients (31 hips), ASR in 23 patients (27 hips) and Durom resurfacing implant in 15 patients (17 hips).

Index operations in Study III were performed over a six-year period, during which different orthopaedic surgeons had exercised different preferences for MoM HR devices at our institution. This explains the use of so many different MoM device brands during the study period. The median femoral component diameter in female patients was 46 mm (42 mm to 52 mm) and in male patients 53 mm (48 mm to 60 mm).

Details of the femoral components used in Study IV are shown in Table 10. Stems manufactured by DePuy were used in all ASR™ XL THAs: a proximally coated Summit® stem in 233 (74%), a HA-coated Corail® stem in 54 (17%), and an S-ROM® stem in 24 (8%) operations. Furthermore, a short Proxima™ stem was used in two operations (1%). One patient received an ASR HR prosthesis in one hip and an ASR™ THR prosthesis in the other hip.

	Cohorts		p value
	HR	THA	
Femoral diameter (mm)			
Median (range)	47 mm (43-49)	47 mm (43-49)	
≤ 46	83 (49%)	133 (43%)	0.14
> 46	86 (51%)	180 (57%)	

Table 10. Femoral components used in Study IV

In Study V all patients had received BHR implants. Implant details are shown in Table 11.

	Males	Females
Median femoral diameter (range)	54 mm (46 to 58)	50 mm (42 to 54)
Femoral diameter		
42 mm	0	2
46 mm	4	39
50 mm	59	36
54 mm	77	7
58 mm	37	0

Table 11. Femoral components used in study V.

All primary operations in Studies I, III and V were performed by or under the direct supervision of four experienced hip surgeons and according to the standard protocol at our institution. A modified posterior approach, with the patient in lateral decubitus position, was used in all operations. Cups were implanted in a press-fit manner, whereas all femoral components were cemented. In each case external rotators were detached along the incision of the posterior capsule and reattached by drill holes to the greater trochanter.

A single-dose parenteral prophylactic antibiotic therapy with cefuroxime was administered two hours before the operation. Thromboembolic prophylaxis with a daily subcutaneous injection of enoxaparin, dalteparin or fondaparinux was used four weeks postoperatively or until the international normalized ratio (INR) had been at a therapeutic level for two days in patients on preoperative oral warfarin treatment.

On the first postoperative day, walking exercises with crutches and full weight-bearing were begun. One surgeon preferred restriction to a combination of flexion and internal rotation four weeks postoperatively whereas the other surgeons allowed full movement immediately.

In Study IV all primary operations were performed by or under the direct supervision of seven experienced hip surgeons and according to the standard protocol at our institution. Postoperatively patients were allowed immediate full weightbearing with crutches and with no major restrictions of movement.

4.2.3 Screening protocol (Studies IV and V)

All patients participating in Study IV were referred for both WB metal ion analysis and cross-sectional imaging using MRI with MARS. If magnetic artefact reduction sequence MRI was contraindicated or could not be done because of patient-related factors (such as claustrophobia), the patient underwent ultrasonography of the affected hip.

All patients participating in Study V were referred to WB metal ion measurements at the time of the latest follow-up. All patients with elevated WB Co or Cr levels or with hip complaints were moreover referred to cross-sectional imaging. Hip complaints included frequent or continuous groin pain, discomfort, sense of instability and /or impaired function of the hip as well as sounds (clanking, squeaking) from the hip. WB metal ion levels were considered elevated if either Cr or Co exceeded 5 ppb (Hart et al. 2011b).

Patients with complaints or with elevated WB metal ion levels were distributed over three groups; group 1: elevated Co or Cr and symptomatic, group 2: elevated Co or Cr and asymptomatic, group 3: non-elevated Co and Cr and symptomatic.

4.2.4 Radiographic evaluation

4.2.4.1 Studies I, IV and V

Patients attending for follow-up examination at our institution had anteroposterior and lateral radiographs of the hip and anteroposterior radiograph of the pelvis taken prior to the visit.

For the purposes of Study I all available radiographs were studied for radiolucency, osteolysis and heterotopic ossification. Radiolucency and osteolysis around the femoral component were classified according to Figure 4 and on the acetabular side as described by Delee and Charnley (1976). Heterotopic ossification was assessed by Brooker scale (Brooker et al. 1973).

Any findings indicating impingement were examined and categorized to anterior, cranial (lateral) or posterior or any combination of these. The stem-shaft

angle and the width of the neck were also measured. Width of the neck was determined as indicated in Figure 4. Neck thinning over 10% compared to radiograph taken immediately after the index operation was considered significant. Acetabular inclination was calculated against the horizontal line between ischial tuberosities (Figure 5). In cases where the cup shadow overlapped the femoral component the centre line of the cup opening was assessed as in Figure 5. Qualitative analysis was performed by two senior orthopedic surgeons.

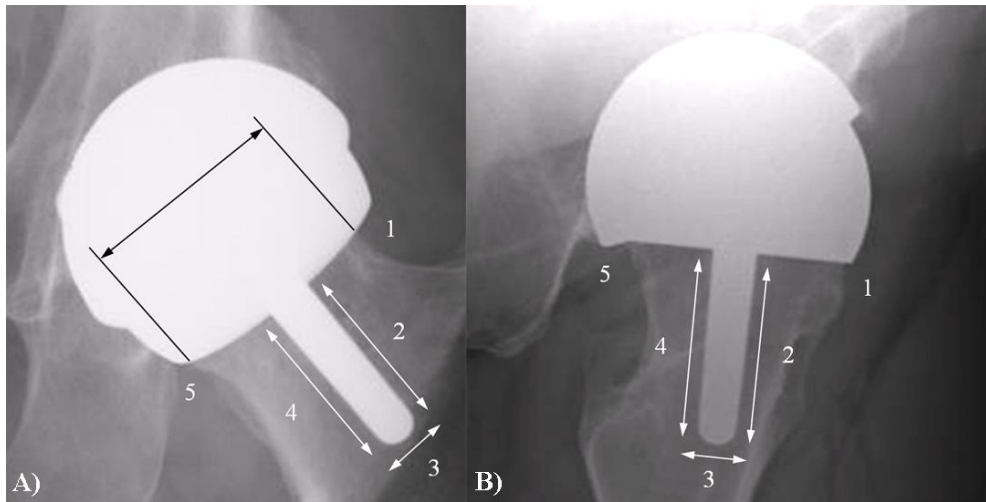

Figure 4. A) Radiological division (indicated AP1,AP2,AP3,AP4 or AP5) of anteroposterior radiograph and definition of neck width. 1=superior aspect of the neck, 2=superior aspect of the tip, 3=lateral aspect of the tip, inferior aspect of the tip, 5=inferior aspect of the neck. B) Radiological division (indicated Lat1, Lat2, Lat3, Lat4 or Lat5) of lateral radiograph. 1=anterior aspect of the neck, 2=anterior aspect of the tip, 3=inferior aspect of the tip, 4=posterior aspect of the tip, 5=posterior aspect of the neck.

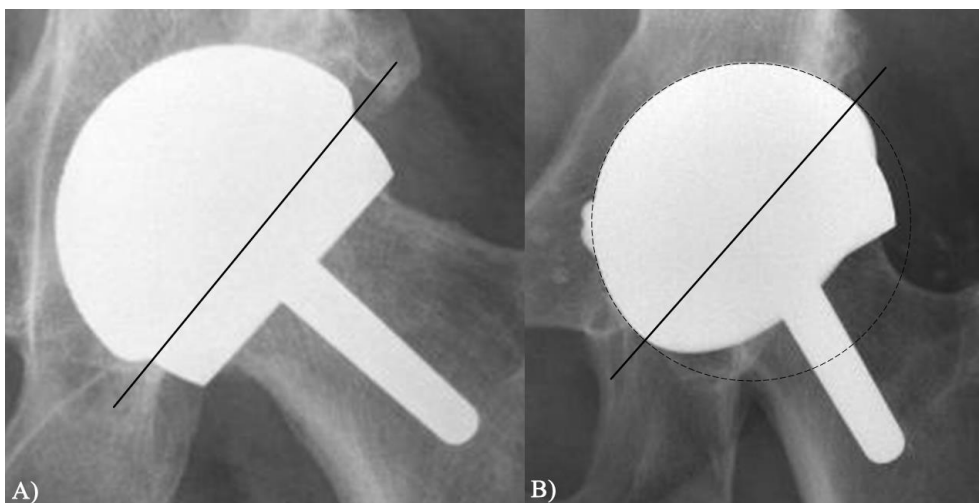

Figure 5. Definition of cup inclination in two different situations. A) The line is drawn through point where shadows of cup and femoral component intersect. B) The circle is drawn according to the outline of the cup shadow and then a line is drawn through the points where cup of the shadow diverges from the circle.

In Study V post-operative plain radiographs taken at the time of screening were analysed for radiolucent lines, osteolysis and pedestal sign. Locations of radiolucent lines and osteolysis were categorized according to Pollard et al. (Pollard et al. 2006). Zones 1-3 refer to Amstutz zones 1-3 in AP radiographs and zones 4-6 refer to the same zones in the lateral radiographs (Amstutz et al. 2004). Presence of osteolysis was also analysed in the proximal collum-implant interface and was categorized as anterior, posterior, cranial (lateral) or inferior (medial).

Pedestal sign was evaluated as described by Pollard et al. (Pollard et al. 2006). Quantitative analysis of the radiographs included acetabular inclination (AI) and version. AI was calculated against the horizontal line between ischial tuberosities and version was assessed as described in Study II. Both calculations were done twice from the two latest pelvic anteroposterior radiographs. “Optimal” acetabular orientation was defined as the “safe-zone” described by Lewinnek et al. (1978). The same zone for cup position was also used in the study regarding pseudotumours in well-positioned, low-wearing cups (Matthies et al. 2012).

Qualitative analysis in Study V was performed by a senior musculoskeletal radiologist (PE).

Radiological assessment in Study IV included only measurement of the acetabular inclination angle, which was calculated against the horizontal line between ischial tuberosities.

4.2.4.2 Study II

In Study II a novel method to assess cup version was used. Cup anteversion was calculated as follows:

- 1) Find the centre of rotation (RC) of the cup
- 2) Draw a circle or semicircle or any shape that has an arc continuous to the outline of cup.
- 3) Draw a line from RC to the point where the cup outline diverges from the circle shape outline. It is recommended to trim the length of this line and draw it to another edge of the cup. Line in another side of the cup should cross the same diversion point.
- 4) Draw a line perpendicular to the previous line and through the point where cup outline and femur component outline intersect (component corner).
- 5) Measure the distances r, e and p (Figure 6).
- 6) Anteversion can be calculated as:

$$Version = \sin^{-1}\left(\frac{p}{\sqrt{r^2 - e^2}}\right)$$

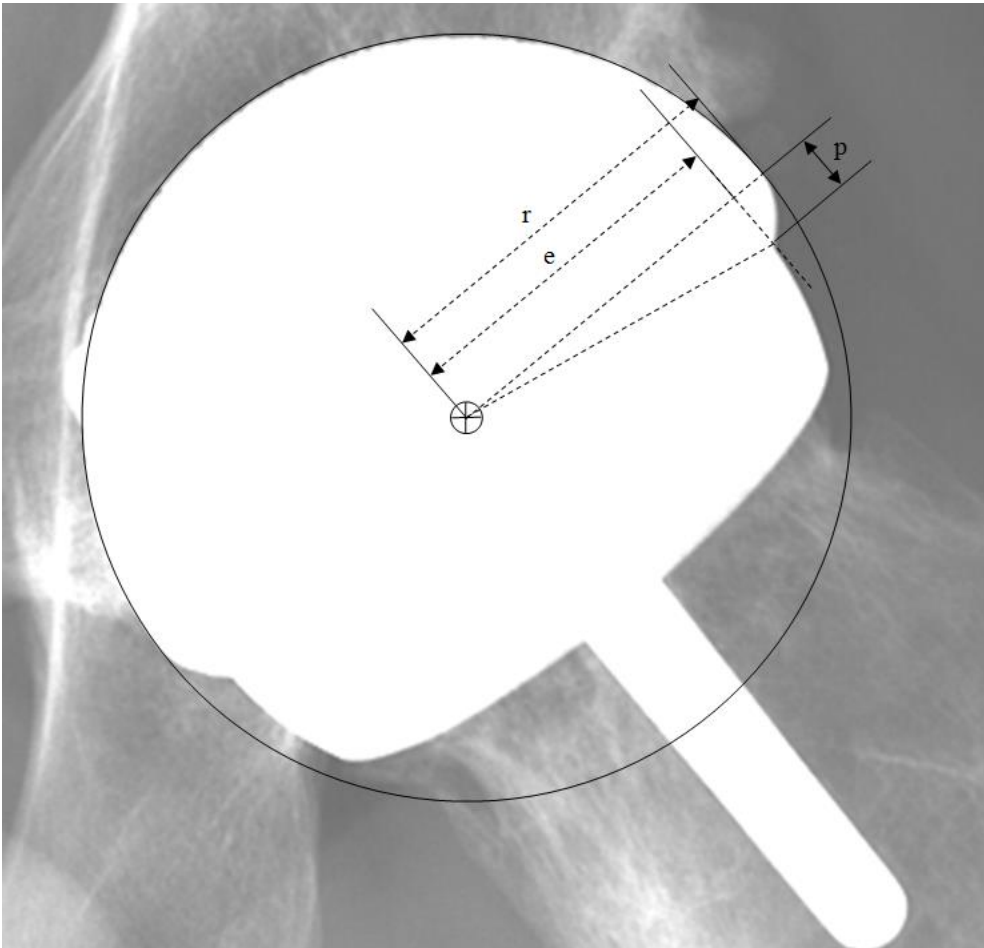

Figure 6. Measurements needed in the assessment of cup orientation.

The formula was derived as follows. The dashed circle in Figure 7 represents the cup opening with version 0 in xy plane. The solid circle represents the cup opening with version α in xy plane. When viewed from the y direction this circle shows as ellipse as in Figure 8. In Figure 8, r equals the R^A in Figure 7. Line p is a line perpendicular to r or R^A from a random point in the arc of the ellipse. Version α is one of the sharp angles in the right triangle in Figure 7. Thus the angle α can be calculated as $\sin^{-1}(a/p)$. Line a , however, cannot be directly measured in xz plane. Because the two circles representing cup opening are the same R_B equals R_A and by Pythagoras' Theorem the length of line a can be calculated and the denominator in the formula represents line a .

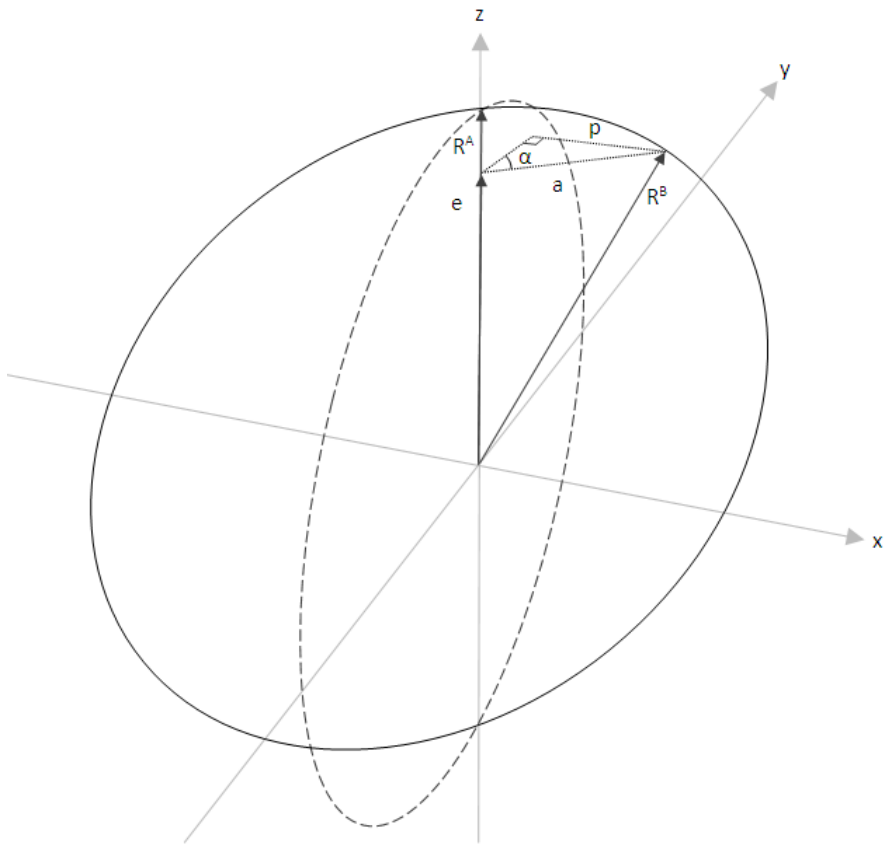

Figure 7. Two iso circles representing cup opening with version of 0 and α degrees.

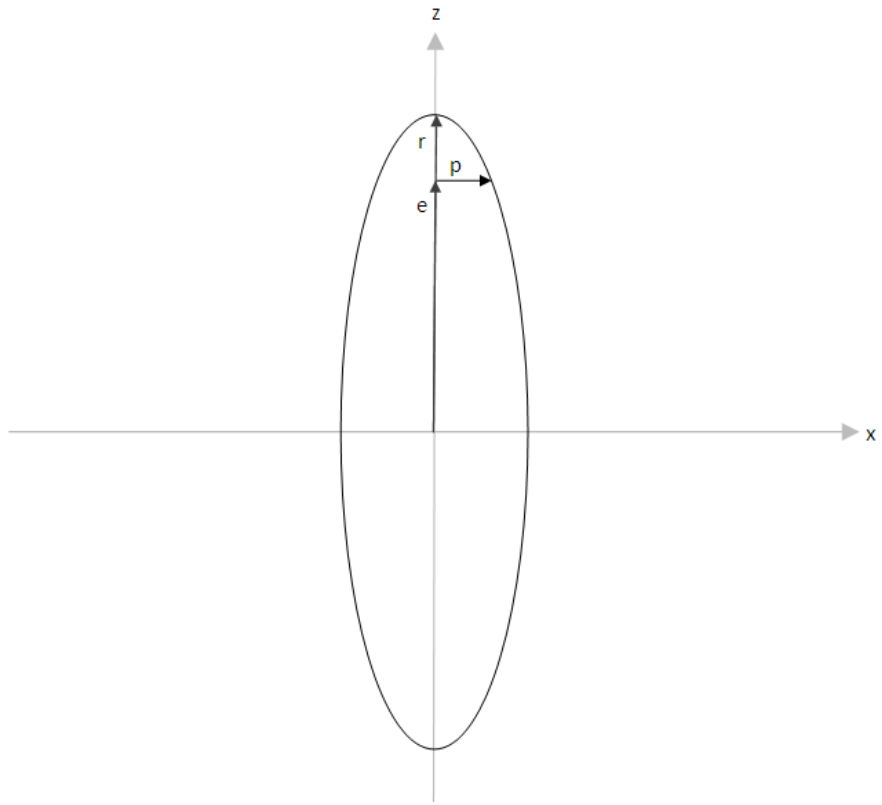

Figure 8. Iso circles of figure 7 viewed in y-direction.

The inclination of the cup is the angle between the major semi-axis of the ellipse formed by the cup opening and the horizontal reference line. Lines r , e and all lines parallel to them represent the major semi-axis of the ellipse.

The shadows of the components in the radiographs can be classified in four different ways: 1) the most common case is where both component corners can be seen, 2) only one component corner can be seen when the cup shadow overlaps the femur component, 3) only one component corner can be seen in the dysplasia cup, 4) no corners can be seen when the dysplasia cup overlaps the femur component (Figure 9). This method can be applied to all these cases.

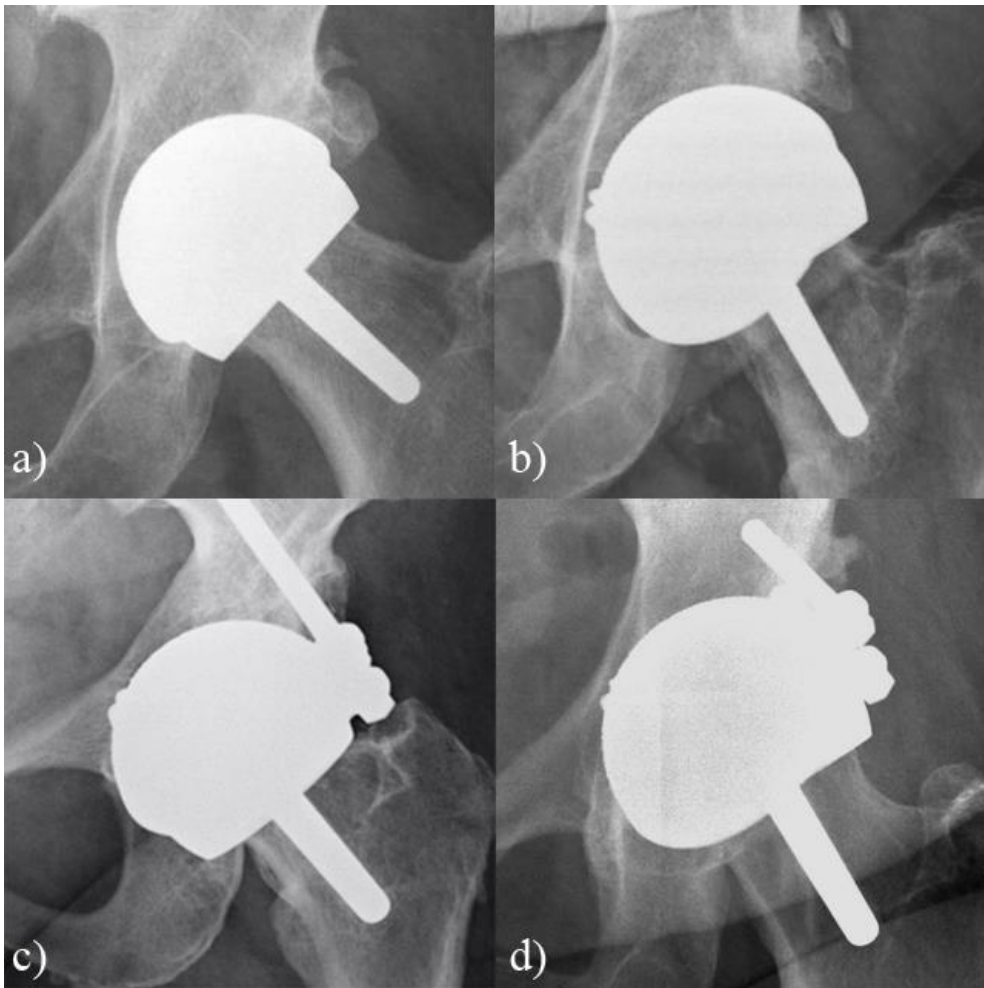

Figure 9. a) BHR components in neutral position showing both component corners, b) BHR cup anteverted overlapping the femoral component, c) BHR dysplasia cup in normal position, d) BHR dysplasia cup anteverted overlapping the femoral component.

4.2.5 Whole blood metal ion analysis

All patients attending the screening protocols in Studies IV and V had their blood samples taken from the antecubital vein using a 21-gauge needle connected to a Vacutainer™ system (Becton, Dickinson and Company Franklin Lakes, NJ, USA) and trace element blood tubes containing sodium EDTA. The first 10 mL of blood was used for other laboratory tests such as C-reactive protein and erythrocyte sedimentation rate measurement. The second 10 mL was used for Co

and chromium analysis. In the Finnish Institute for Occupational Health, standard operating procedures were established for Co and chromium measurement using dynamic reaction cell inductively coupled plasma (quadrupole) mass spectrometry (Agilent 7500 cx, Agilent Technologies, Santa Clara, CA, USA).

4.2.6 Cross-sectional imaging

The MRIs in Studies IV and V were performed on two 1.5-T machines (Siemens Magnetom Avanto 1.5 T; Siemens Healthcare, Erlangen, Germany; and GE Signa HD 1.5 T; General Electric Healthcare, Waukesha, WI, USA). All examinations were done with magnetic artefact reduction sequence: coronal and axial T1-weighted fast spin echo and coronal, axial, and sagittal short tau inversion recovery. Magnetic artefact reduction sequence MR images were analysed by the co-author (PE) and two other senior musculoskeletal radiologists in Study IV. In Study V one co-author (PE) analysed all images.

In the US, pseudotumour was defined as an extra-articular mass adjacent to a joint which was thick-walled or solid, and synovia was considered hypertrophic if it exceeded 5 mm in width. US examinations were performed with Logiq e9 (GE Healthcare, Wisconsin, USA) and graded using grading similar to that applied to the MRI findings by the same musculoskeletal radiologist (PE).

4.3 Statistical methods

In each study Student's t-test was used when comparing normally distributed variables between groups and non-parametric variables were compared using the Mann-Whitney U test. The Wilcoxon signed rank-sum test was used to compare preoperative and postoperative scores in the same patient.

In Study II four different observers calculated the version and inclination from every hip twice with a minimum one-week interval. The first observer (Observer A) was the person who developed the formula and who is also familiar with the computing software. The method was briefly introduced to three other observers. Two (Observers B and C) were senior orthopaedic surgeons familiar with the computing software. The fourth observer (Observer D) was not familiar with the computing software - mediCAD 2.04 templating software (HECTEC GmbH, Germany) was used by observers A and D whereas IMPAX Orthopaedic Suite (Agfa Healthcare, Mortsel, Belgium) was used by observers B and C. The observers were not instructed to calibrate the images in the same manner.

Intra-observer reliability in Study II was estimated by mean error between two sets of measurements. Standard deviation was also calculated for the mean errors. Pearson's correlation coefficient was used to estimate intra-observer reliability, i. e. the similarity of the two consecutive measurements for each observer.

The first series of measurements for version and inclination from each observer was then chosen for the inter-observer analysis. This enabled us to increase the sensitivity of the inter-observer analysis instead of calculating the mean values of the two measurement series. Bland-Altman plots for version and inclination were calculated between each observer. For four observers there are four paired plots. First they were drawn between A and B, A and C and B and C. Subsequent plots were drawn between A and D, B and D and C and D. These were drawn for both version and inclination. Mean error and 95% limits of agreement were calculated between observers as proposed by Bland and Altman (1986). Intraclass correlation coefficient was used to analyse the variability between the observers.

Kaplan-Meier survival analysis was used in Studies I, III, IV and V to construct the survival probability and the analysis was stopped when hips at risk dropped below 20. Comparison of survivorship by strata factor was performed using the log-rank test.

Cox regression analysis was performed to estimate risk factors for ARMeD in Study IV. Continuous variables were distributed to the appropriate subgroups. For age, a cutoff value of 50 years was used. A cutoff value of 40 years used by others would have led to too small subgroups, since only 36 patients in our study group were younger than 40 years. Femoral diameter was analysed as a continuous variable. Acetabular inclination was divided into two groups: 50° or less and greater than 50°. Preoperative ROM was divided into two groups based on the mean value minus ½ SD, which yielded the following distribution: less than 110° and 110° or greater in the THR group and less than 130° and 130° or greater in the HR group.

In order to study appropriately the influence of cup position on the risk of ARMeD, head size and acetabular inclination were combined and cup coverage was used in the adjusted Cox regression analysis. Cup coverage is equal to the lateral acetabular component edge, as previously described (Figure 10) (De Haan et al. 2008).

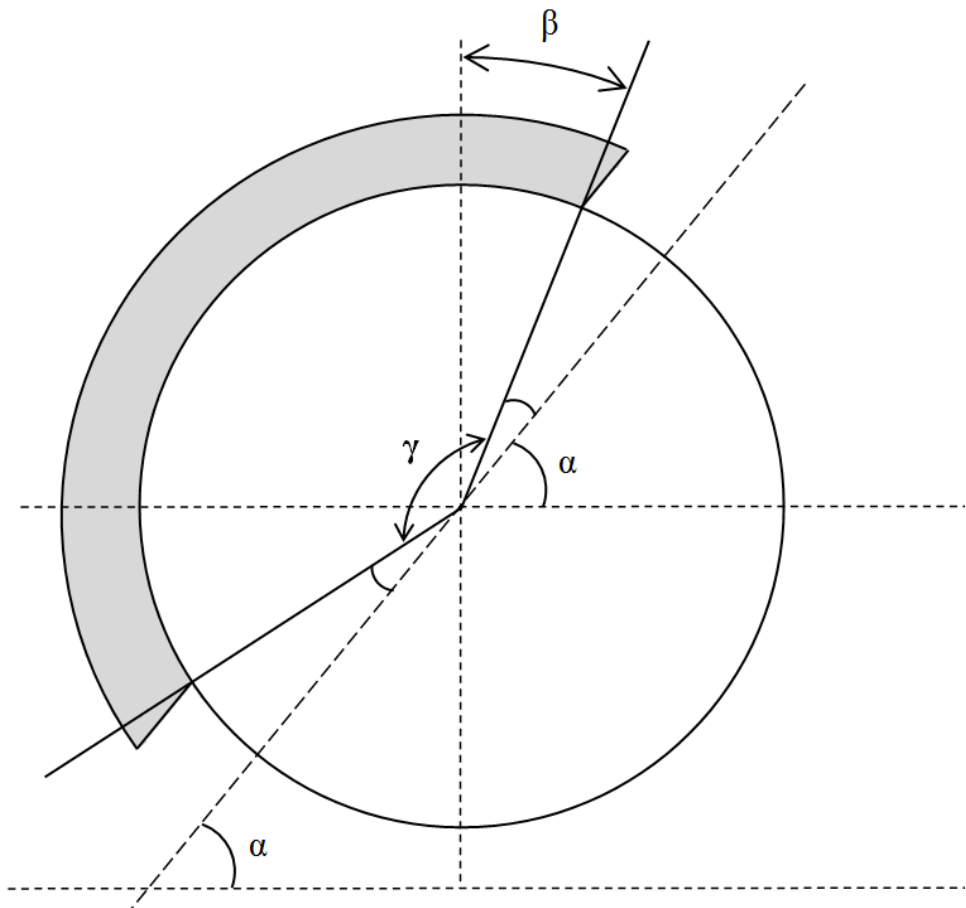

Figure 10. Definition of cup coverage. γ = FA, α = acetabular inclination, β = cup coverage. Cup coverage = $90 - (180 - \gamma)/2 - \alpha$

Subtended acetabular component angle or FA was obtained from the ASR™ cup templates in AGFA software Version 11.6 (Agfa, Greenville, SC, USA) (Figure 11). FA was calculated for each femoral size. The average of three calculations was used to assess the correlation of FA with femoral size. The assessment yielded the biphasic distribution of the arcs. FA correlated significantly with cup size in sizes from 39 mm to 47 mm (slope, $0.75^\circ/\text{mm}$; $r^2 = 0.9959$). In larger cups, the correlation was also significant (slope, $0.50^\circ/\text{mm}$; $r^2 = 0.9953$) (Figure 12). Because there was no relevant correlation with cup coverage and femoral diameter ($r^2 = 0.081$, $p = 0.051$), the latter also was included in the multivariate analysis

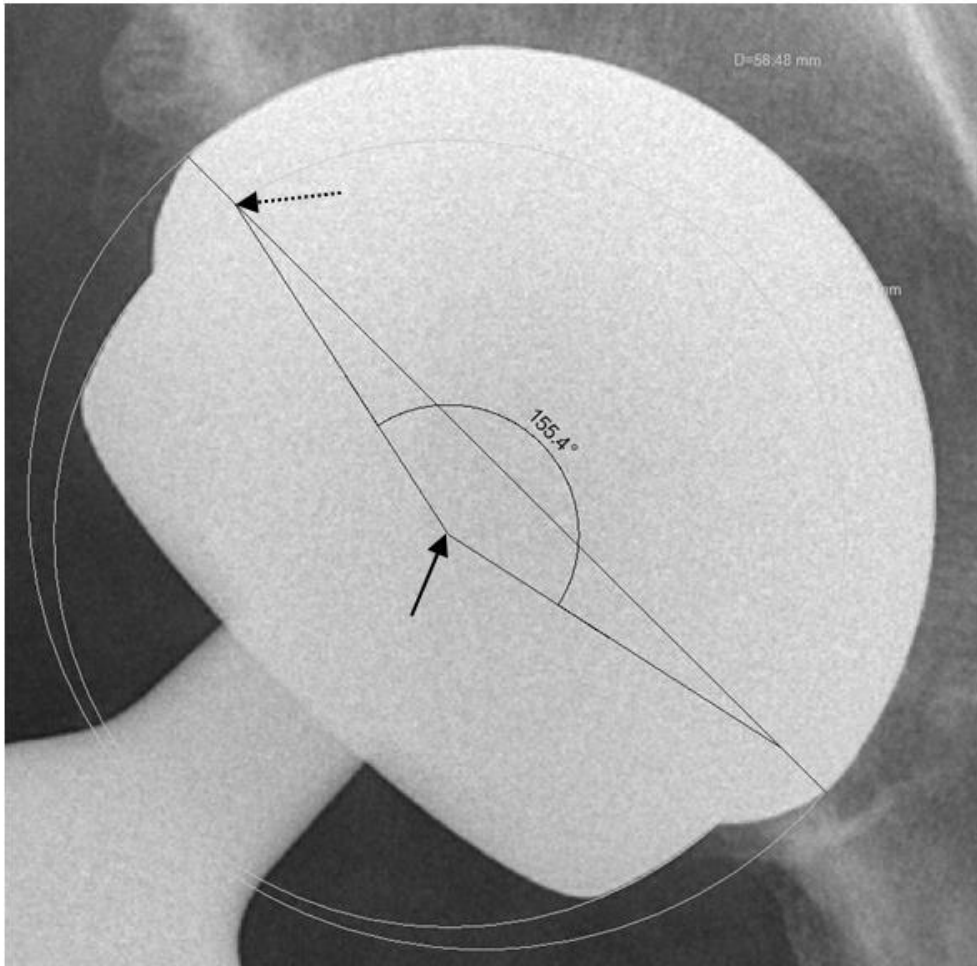

Figure 11. Screenshot from AGFA software showing the calculations needed to assess FA of cup. Solid arrow indicates center of rotation of the femoral head. Dotted arrow indicates the point where femoral diameter diverges from the cup edge.

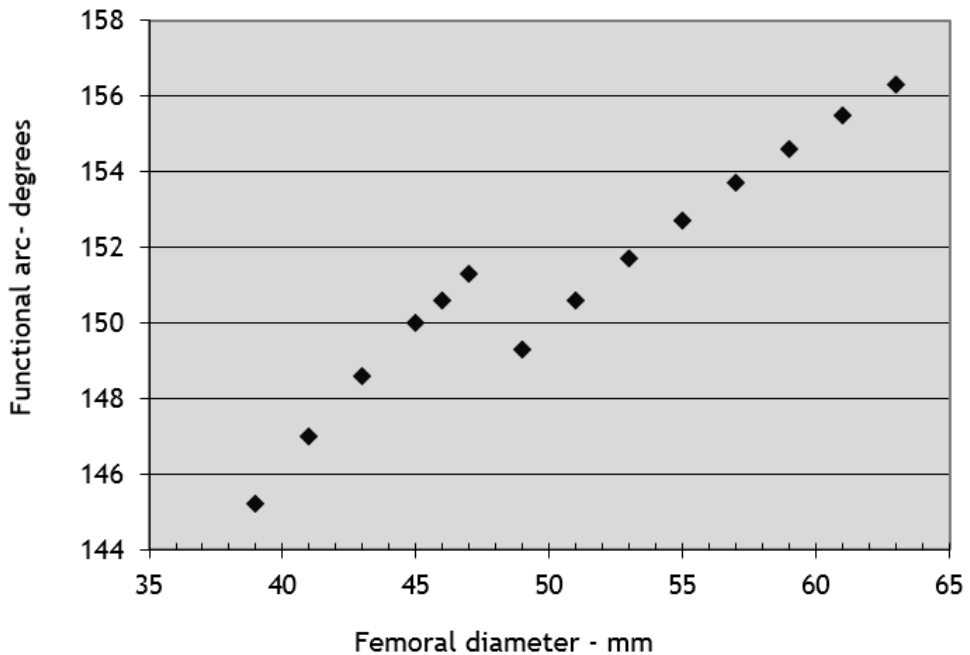

Figure 12. Association between femoral diameter and FA.

In addition to the aforementioned categorical variables, gender and implant type (HR versus THA) were studied as risk factors for adverse reactions to metal debris in Study IV. Cox regression analysis was used to estimate the unadjusted (crude) and adjusted risk ratios of different variables on the risk of adverse reactions to metal debris-related failure.

The Wald test was applied to calculate p values for data obtained from the Cox multiple regression analysis. Because femoral diameter is known to be smaller in female patients, we estimated colinearity between the variables used in the Cox regression model by calculating variance inflation factors. Variance inflation factors were obtained by multivariable regression analysis using follow-up as a dependent variable.

In Study V including 261 BHRs subgroup analyses were performed for male patients with femoral diameter of 50 mm or higher and results were analysed separately for this group. In this patient group HR was shown to have a five-year survival rate comparable to that of THR (NJR 2013).

4.4 Ethical considerations

Ethics committee approval was not obtained for Studies I ja II due to their retrospective nature and the absence of any intervention.

Informed consent was obtained from all participants in Studies III, IV and V. The authors obtained permission to conduct each study from the ethics committee of the hospital district in which the work was performed (Study III: R10077, Study IV: R11006, Study V: R11196).

5 Results

5.1 Studies I and V

5.1.1 Cumulative survival and revisions of patients operated on with BHRs

For the first 126 patients (144 hips) operated on with BHRs at our institution (Study I) the mean follow-up time was 6.0 years (range 4.7-7.8 years). Four of the 122 hips in regular follow-up were operated on for a second time.

Of the 16 patients approached by letter, ten returned the questionnaire and another two patients were contacted by phone. All twelve patients still had a functioning prosthesis.

The cumulative six-year survival rate of the 144 BHRs was 96.7% (95% CI, 95.0 to 98.4). The cumulative survival rate at mean six years was 97.7% for males and the five-year survival rate was 95.2% for females. Two failures occurred in male and two in female patients. The information concerning the revised prostheses is shown in Table 12.

Patient	Age	Gender	Time to revision	Etiology	Operation	New bearings	Result
1	47	Female	5.9 y	ALVAL (and metallosis)	Cup/stem revision	CoC	Pain free
2	58	Male	3.8 y	Neck fracture due to caput necrosis	Stem revision	MoM	Squeaker
3	62	Male	4.0 y	Malposition due to caput necrosis	Stem revision	MoM	Mild pain
4	53	Female	3.8 y	ALVAL (and metallosis)	Cup/stem revision	MoP	Pain free

Table 12. Reoperated patients of the Study I. CoC = ceramic-on-ceramic

At the time of going to press 23 hips in 21 patients had been revised after the systematic screening for ARMeD (Study V) including larger cohort of 219 patients with 261 BHRs. The most common mode of failure was ARMeD (Table 13). One revision was pending. One male patient with pseudotumor from Group 1 had not consented to revision when the study was completed.

	Number of revised hips (proportion all hips)		
	Males	Females	Total
ARMeD	3 (1.9%)	8 (9.9%)	11 (4.6%)
ON	3 (1.9%)	1 (1.2%)	4 (1.7%)
Neck fracture	1 (0.6%)	3 (3.7%)	4 (1.7%)
Infection	1 (0.6%)	1 (1.2%)	2 (0.8%)
Impingement	1 (0.6%)	0 (0%)	1 (0.4%)
Pain	1 (0.6%)	0 (%)	1 (0.4%)
Total	10 (6.3%)	13 (20%)	23 (9.6%)

Table 13. Reasons for revision by sex in Study V.

The ten-year survival for this larger cohort with any revision at end-point was 90.7% (95% CI 88.7% to 92.7%). Ten-year survival rate was 93.1% (95% CI 91.0% to 95.2%) in male and 86.0% (95% CI 82.1% to 89.9%) in female patients (p=0.046).

5.1.2 Clinical results

For the first 126 patients (144 hips) operated on with BHRs at our institution (Study I) the mean preoperative HHS of the cohort was 55.0 (24 to 83). In the latest follow-up examination median HHS was 100 (52-100). Preoperatively the mean total ROM (flexion, extension, abduction, adduction, external and internal rotation) was 120 degrees and in follow-up it had improved to 242 degrees on average.

Nine patients who returned the questionnaire reported being pain-free and that their functional outcome was good. Five patients experienced pain and three of them considered it mild. One patient reported moderate pain.

Overall satisfaction of the 116 patients was 2.53 on a scale 0-3. Seventy patients reported excellent satisfaction, 39 patients good satisfaction, six patients fair satisfaction and one patient reported poor satisfaction. The proportion of patients who were highly satisfied was significantly higher in male patients (65% vs. 51%, p=.02).

Of the patients included in Study I three experienced squeaking, and two were among those revised.

In the patients included in Study I paresis of the peroneal nerve on the operated side was diagnosed in two patients, one of whom also had paresis of the femoral nerve. Three prostheses caused a squeaking sound and two were revised.

During the six-year follow-up in Study I no dislocations or infections were detected.

At the time of the final follow-up visit in Study V with a larger cohort of BHR patients, mean and median postoperative HHS were 94.0 points and 100 points (range 52 to 100), respectively. Mean total ROM was 240 degrees. Hip flexion was 114 degrees on average, abduction 35 degrees, adduction 28 degrees, internal rotation 27 degrees and external rotation 34 degrees. Six patients (eight hips) reported frequent sounds originating from the resurfaced hip.

5.1.3 Radiographic analyses

The radiological findings of Study I are listed in Table 14. Neck thinning of over 10% was seen in seven patients. Mean stem-shaft angle was 137 degrees. The mean abduction angle of the acetabular component was 48.0 degrees.

The mean abduction angle of the cups in the revised group (four hips) was 55.9 degrees. The abduction angles of the cup in our two ALVAL and metallosis patients were 64 and 61 degrees. Two other female patients had inclination over 60 degrees both of which also had neck thinning over 10%.

Finding	Grading or location	Number of hips (proportion)
Radiolucency	AP3	1 (0.9%)
	AP5	1 (0.9%)
Osteolysis	AP1	1 (0.9%)
	AP5	1 (0.9%)
	Lat1	2 (1.8%)
	Lat5	3 (2.7%)
	AP1 and AP5	1 (0.9%)
	Lat1 and AP1	1 (0.9%)
Heterotopic ossification	Brooker I	9 (8.1%)
	Brooker II	1 (0.9%)
	Brooker III	5 (4.5%)
	Brooker IV	1 (0.9%)
Impingement	Anterior	10 (9.0%)
	Posterior	1 (0.9%)
	Antero-cranial	1 (0.9%)

Table 14. Results of radiographic analyses in Study I

In Study V mean version and inclination of the acetabular components were 21.4 degrees (SD 6.6) and 48.6 degrees (SD 6.7) respectively. Of the hips 43.9% had inclination over 50 degrees. There was no difference in WB metal ion levels between patients with inclination over 50 degrees and those patients with inclination under 50 degrees (Cr: 1.50 ppb vs. 1.80 ppb, $p=0.4$; Co: 1.45 ppb vs. 1.70 ppb, $p=0.5$). “Optimal” acetabular orientation (inclination 40 ± 10 degrees, version 15 ± 5 degrees) was seen in 29.0% of the hips. However, no difference in WB metal ion levels was observed when patients with “optimal acetabular orientation” were compared to those with cup position outside the optimal zone (Cr: 1.70 ppb vs. 1.60 ppb, $p=0.9$; Co: 1.45 ppb vs. 1.60 ppb, $p=0.4$).

A summary of the qualitative radiological analysis is shown in Table 15. Osteolysis was seen in 43 (20.3%) hips (3.3% on the acetabular side, 19.2% on the femoral side). Radiolucencies were seen in 23 (10.9%) hips (4.3% on the acetabular side, 7.6% on the femoral side).

Patients with a pedestal sign had statistically significantly higher median WB Cr level than patients without a pedestal sign (1.50 ppb vs 1.30 ppb, $p=0.035$). No difference was seen in median WB Co ion levels (1.20 ppb vs. 1.20 ppb, $p=0.2$). Neither was there any difference in median WB metal ion levels when patients with osteolysis were compared to those without (Co: 1.10 ppb vs. 1.20 ppb, $p=0.97$; Cr:

1.30 ppb vs. 1.40 ppb, $p=0.98$) nor between patients with radiolucent lines compared to those without (Co: 1.20 ppb vs. 1.20 ppb, $p=0.86$; Cr: 1.40 ppb vs. 1.20 ppb, $p=0.82$).

Femoral side		Cases with osteolysis (proportion of all cases)	Cases with radiolucent lines (proportion of all cases)
Zone	Amstutz 1	8 (3.8%)	13 (6.2%)
	Amstutz 2	3 (1.4%)	2 (0.9%)
	Amstutz 3	8 (3.8%)	7 (3.3%)
	Amstutz 4	9 (4.3%)	3 (1.4%)
	Amstutz 5	5 (2.7%)	0
	Amstutz 6	6 (2.8%)	6 (2.8%)
	Anterior neck	25 (11.8%)	-
	Posterior neck	9 (4.3%)	-
	Inferior neck	12 (5.7%)	-
	Lateral neck	9 (4.3%)	-
Acetabular side		Cases with osteolysis (proportion of all cases)	Cases with radiolucent lines (proportion of all cases)
Zone	Charnley-Delee 1	6 (2.8%)	6 (2.8%)
	Charnley-Delee 2	3 (1.4%)	4 (1.9%)
	Charnley-Delee 3	3 (1.4%)	5 (2.7%)

Table 15. Summary of osteolysis and radiolucent lines in Study V.

5.1.4 Cross-sectional imaging

In total, 30% (48 patients, 56 hips) of 219 patients included in Study V had elevated WB Cr or Co levels and/or were symptomatic and thus were referred to cross-sectional imaging (Figure 13). Median time to imaging was 9.0 years (range 7.2 to 11.1 years). Nine pseudotumours, five thin-walled fluid-filled (class 1) and four thick-walled with atypical content (class 2B) were identified in eight patients by MRI (Table 16). US revealed four more pseudotumours in four patients. All PTs seen in US appeared irregular in shape with thick walls meeting the criteria for Imperial class 2B.

Eight patients (ten hips) were both symptomatic and had elevated blood metal ion levels (WB Co or Cr > 5 ppb) (Group 1 in Figure 13) (Table 16). Of the two

bilateral patients both reported complaints in only one hip. Imaging revealed PT in five of these eight patients. Twelve patients (14 hips) were asymptomatic, but had elevated blood metal ion levels (Group 2) (Table 16). Cross-sectional imaging revealed a pseudotumour in five out of 12 patients in this subgroup. Twenty-eight patients (32 hips) were symptomatic but had low blood metal ion levels (<5 ppb) (Group 3) (Table 16). Cross-sectional imaging was performed on all 28 patients and three pseudotumours (10.7%) were detected. In addition, three asymptomatic patients (three hips) with low blood metal ion levels were imaged due to frequent squeaking of the resurfaced hip. No pseudotumours were detected in these patients.

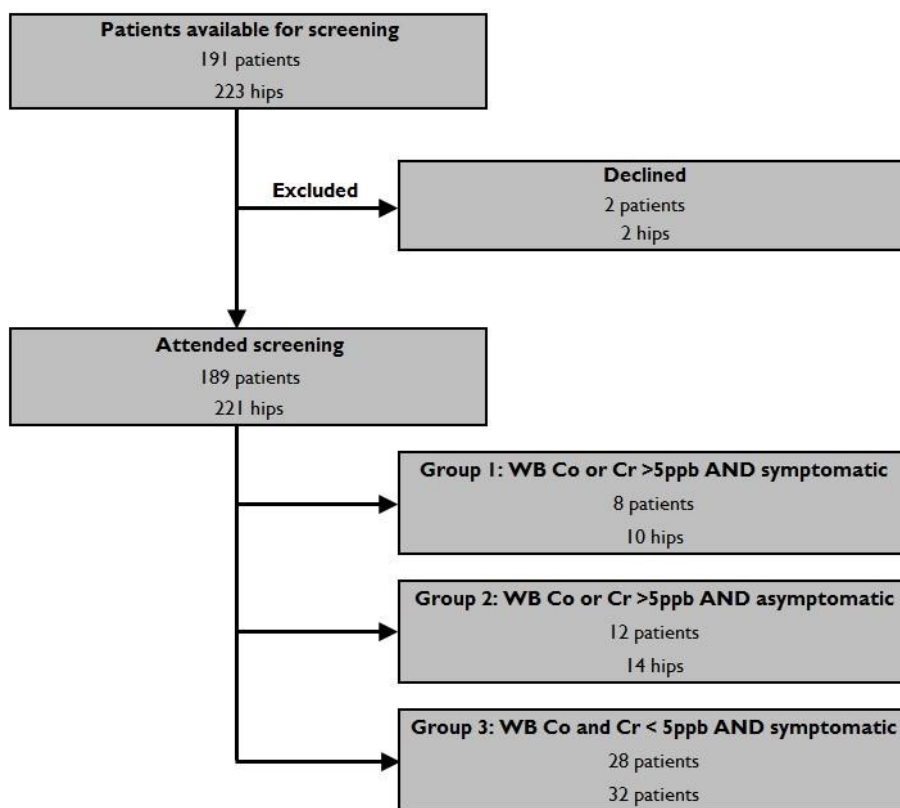

Figure 13. Flow-chart of the screening in the Study V.

		Patients (hips)	Males (%)	Median femoral diameter (range)	Median HHS (range)	Median WB Co (range)	Median WB Cr (range)	Patients with PT
Group 1 Symptomatic patients and elevated WB metal ion levels	Unilat.***	6 (6)	83%	52 mm (50 to 58)	90 (55 to 100)	39.7 ppb (2.10 to 106.3)	21.2 ppb (2.4 to 41.2)	3 (50%) MRI: Two class 2B US: One thick walled (One synovial thickening)
	Bilat.	2 (4)	0%	50 mm (46 to 50)	98 (96 to 100)	89.8 ppb (21.2 to 158.3 ppb)	39.3 ppb (13.1 to 65.4)	2 (100%) US: Two thick walled
Group 2 Asymptomatic patients but with elevated WB metal ion levels	Unilat.**	8 (8)	63%	50 mm (46 to 58)	100 (92 to 100)	8.20 ppb (4.40 to 201.2)	6.00 ppb (3.00 to 93.5)	3 (27.5%) MRI: Two class 1 US: One thick walled (One synovial thickening)
	Bilat.	2 (4)	100%	54 mm (50 to 58)	100 (96 to 100)	6.00 ppb (5.20 to 6.80)	5.95 ppb (3.40 to 8.50 ppb)	2 (100%) MRI: One class 1, one class 2B
Group 3 Symptomatic patients but with non-elevated WB metal ion levels	Unilat.*	24 (24)	63%	54 mm (46 to 58)	85 (52 to 100)	1.30 (0.8 to 4.60)	1.60 ppb (0.70 ppb to 2.90)	1 (4.2%) MRI: One class 1 (US: Three synovial thickenings)
	Bilat.	4 (8)	40%	50 mm (46 to 58)	93 (59 to 100)	1.85 ppb (1.40 to 2.80)	1.90 (.90 to 2.50)	2 (50%) MRI: One class 1, one class 2B

Table 16. Clinical findings of patients with elevated WB metal ions and/or hip complaints. *** Two patients had contra-lateral non-BHR implant. None had PT adjacent to BHR implant. ** Five patients had contra-lateral non-BHR-implant. One had PT (1B) adjacent to BHR implant. * Two patients had contra-lateral non-BHR-implant. Both had PT adjacent to BHR implant.

5.1.5 Male patients with femoral diameter of 50 mm or greater

Ten-year survival rate of male patients with femoral diameter of 50 mm or more in the larger cohort of BHR patients (Study V) was 93.8% (95% CI 91.9% to 95.7%). Of these hips 29.6% had “optimal” acetabular orientation in plain radiographs. Median WB Cr and Co levels in unilateral patients were 1.30 ppb (0.70 ppb to 5.70 ppb) and 1.20 ppb (0.6 ppb to 11.1 ppb) respectively.

In this subcohort of patients, 38 (27.5%) reported symptoms or had elevated WB metal ion levels. Elevated WB Cr and/or Co levels were seen in eight patients, six of whom had a unilateral BHR implant. Six non-revised patients (six hips) in this cohort remained under close surveillance due to suspicious clinical or radiographic findings (Table 17).

Age	Femoral diameter	Clinical findings	Cross-sectional imaging	WB Co and Cr levels	Inclination and version	Other
55 years	54 mm	Fluctuating symptoms	MRI: Slight edema in the gluteal muscles	Cr 7.4 pp, Co 15.1	I 45.7°, V 25.9°	Has not so far consented to undergo revision surgery
46 years	50 mm	Asymptomatic	US: PT	Cr 6.9 ppb, Co 10.5	I 46.3°, V 19.7°	
36 years	50 mm	Asymptomatic	MRI: 1B	Cr 9.5 ppb, Co 8.1	I 59.2°, V 24.6°	
56 years	58 mm	Fluctuating symptoms	MRI: 2B and wide edema in the whole iliacus muscle	Cr 2.0 ppb Co 1.9 ppb	I 50.4°, V 24.7°	Bilateral 58 mm implants
66 years	58 mm	Increasing hip symptoms	US: Synovial hypertrophy	Cr 3.6 ppb, Co 7.1 ppb	I 33.8°, V 16.2°	Has recently become more symptomatic and has been referred once again to cross-sectional
49 years	54 mm	Asymptomatic	MRI: Capsular thickening and intracapsular fluid collection	Cr 3.8 ppb, Co 6.6 ppb	I 60.6°, V 25.2°	

Table 17. Details of male patients included in the study V with femoral diameter of 50 mm or higher who are under close surveillance

5.2 Study II

5.2.1 Intra-observer results

Intra-observer correlations and mean errors for two repeated measurements of version and inclination for each technique requiring an observer developed for this study are presented in Table 18. All correlations were statistically significant ($p < 0.05$).

Observer	Repeated measurements for version		Repeated measurements for inclination	
	Mean error (SD)	Correlation	Mean error (SD)	Correlation
A	0.3 (1.3)	0.97	0.3 (1.7)	0.96
B	-0.28 (2.8)	0.85	-0.1 (2.4)	0.97
C	1.1 (2.1)	0.93	-0.4 (1.8)	0.97
D	-1.8 (3.1)	0.74	-0.6 (2.1)	0.94

Table 18. Intra-observer values for inclination and version.

5.2.2 Inter-observer results

Bland-Altman plots between observers for version are shown in Figure 14 and for inclination in Figure 15. Mean error for version between observers A and B was 0.2 degrees, between A and C 1.0 degrees, between A and D -0.03 degrees, between B and C 0.7 degrees, between B and D 0.7 degrees and between C and D -1.0 degrees. Mean errors for inclination were -0.5, 0.1, -0.2, 0.6, 0.4 and -0.3 degrees in the same manner. Intraclass correlation coefficients for version among observers A, B and C were 0.88 and among all observers 0.79. Same values for inclination were 0.93 and 0.91.

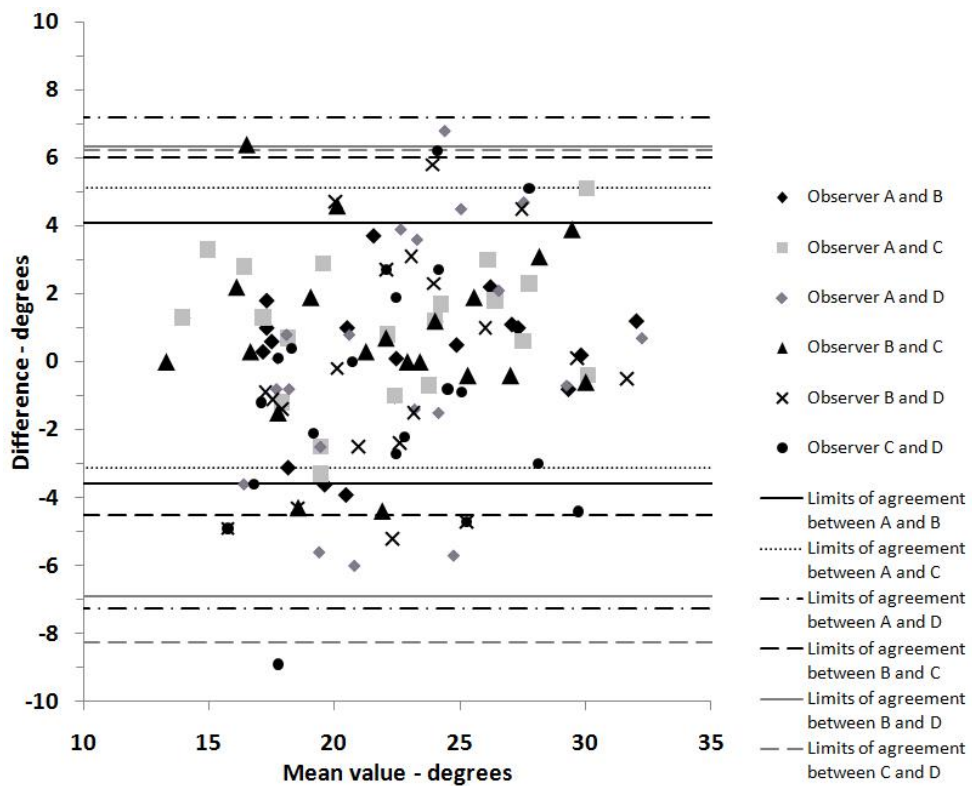

Figure 14. Bland-Altman plot for version measurements.

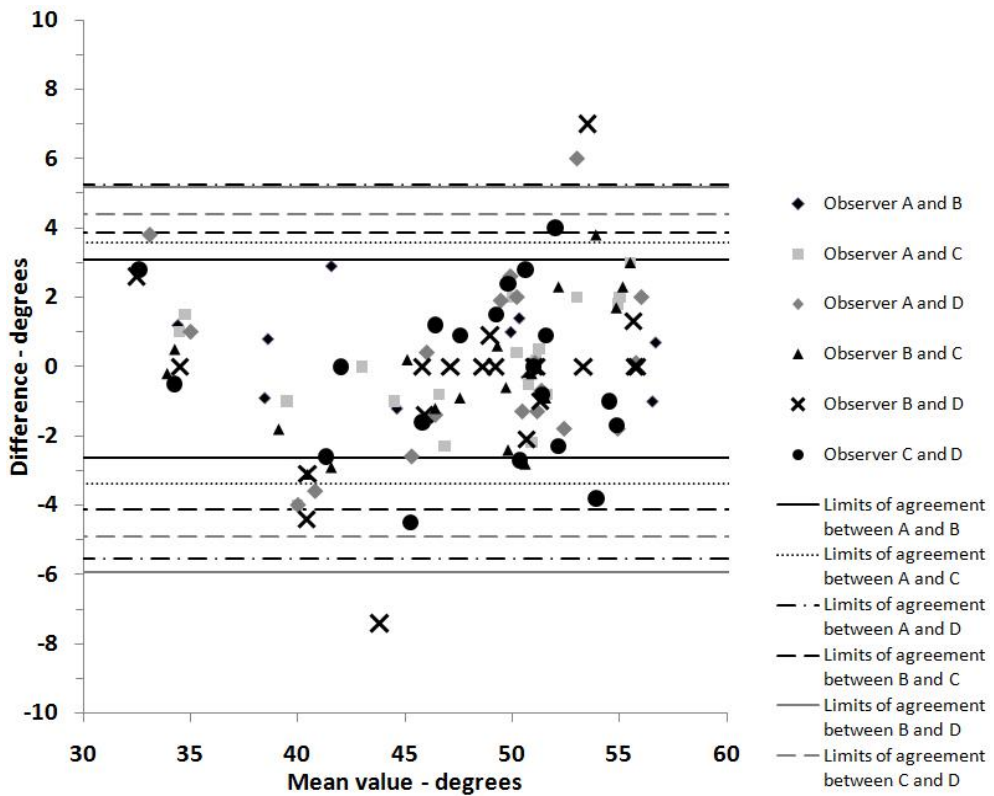

Figure 15. Bland-Altman plot for inclination measurements.

5.3 Study III

5.3.1 Cumulative survival and revisions

Seventy-five HRs were implanted in 64 patients aged 40 or less at the time of the index operation. Of these 75 hips, six (six patients) with ASR implants and two with BHR implants have been revised and seven of these reoperations were performed due to an ARMeD (Table 19).

Age	Sex	Diagnosis	Device	Femoral size	Abduction angle	Time to revision	Symptoms, findings	WB metal ion levels	Operative findings
14	F	SCPE	ASR	46 mm	38 degrees	6.1 years	Painless, neck thinning over 10%	[Co]: 17 µg/l [Cr]: 19 µg/l	Metal stained joint fluid, green-bluish synovia, bone cyst in the neck
15	F	DDH	ASR	43 mm	56 degrees	4.4 years	Moderate pain	[Co]: 217 µg/l [Cr]: 94 µg/l	Extensive metallosis, osteolysis in the acetabular side
39	F	DDH	ASR	46 mm	46 degrees	4.1 years	Mild pain with squeaking	[Co]: 20.1 µg/l [Cr]: 12.2 µg/l	Necrotic synovitis, metal stained fluid, no osteolysis
35	F	DDH	BHR	42 mm	56 degrees	5.2 years	Moderate pain with squeaking	[Co]: 188.9 µg/l [Cr]: 49.8 µg/l	Dark greenish joint fluid, bone cyst in the neck
36	M	Posttraumatic OA	ASR	53 mm	41 degrees	7.6 years	Painless	[Co]: 16.9 µg/l [Cr]: 17.0 µg/l	Greenish joint fluid, extensive metallosis, small osteolysis beneath cement
33	M	OA	BHR	50 mm	55 degrees	8.4 years	Painless, squeaking, bone cyst in the neck	[Co]: 106.3 µg/l [Cr]: 41.4 µg/l	Greyish fluid, extensive metallosis, necrotic mass
27	F	DDH	ASR	51 mm	55 degrees	6.9 years	Painless, squeaking	[Co]: 224.7 µg/l [Cr]: 79.9 µg/l	Extensive metallosis, femoral osteolysis

Table 19. Clinical findings of the patient aged less than 40 years revised due to ARMeD.

Five out of seven hips diagnosed with ARMeD had femoral diameter of 50 mm or less (Figure 16). Acetabular inclination in these hips varied between 38 and 56 degrees (Figure 17). Each of these patients had elevated blood metal ion levels and a PT was diagnosed in five patients using magnetic artefact reduction sequence MRI. A low-echo mass adjacent to the hip joint was seen in ultrasonography in two other hips. In all seven revised patients a diagnosis of ARMeD was confirmed in revision. The pseudotumour was resected and both prosthetic components were changed to a cementless THR with ceramic-on-ceramic articulation.

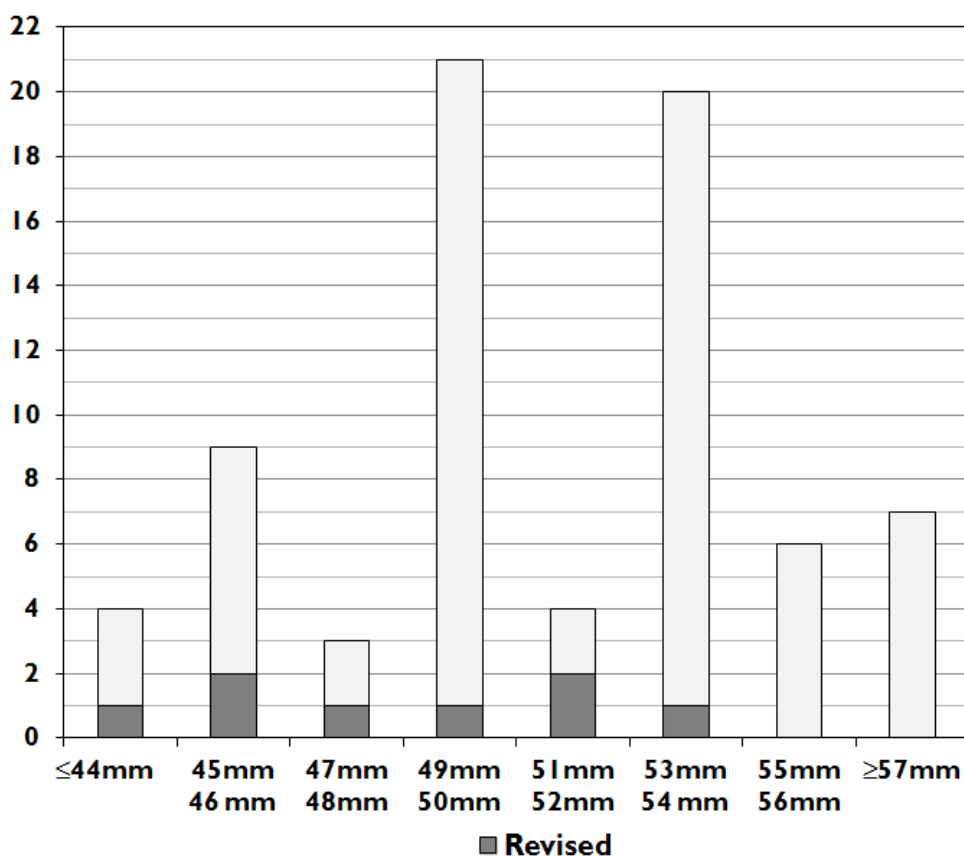

Figure 16. Histogram of femoral diameter showing number of hips revised.

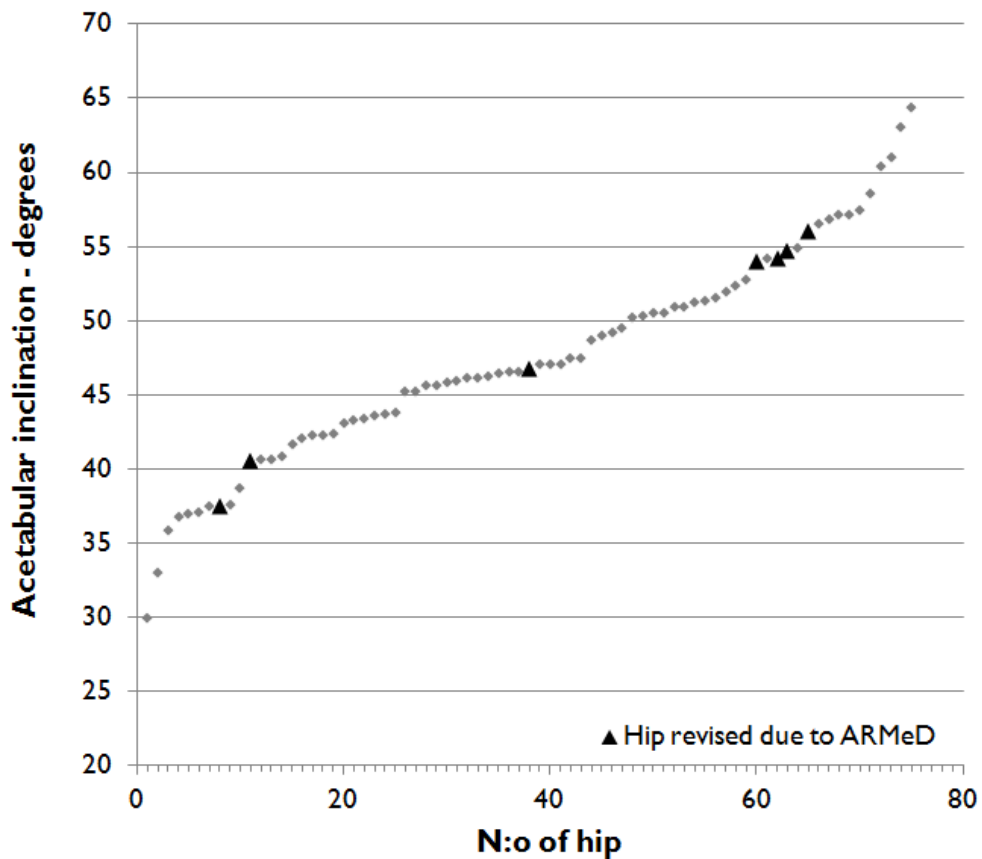

Figure 17. Hips rank ordered according to inclination angle.

Only in one case was a distinct ALVAL reaction seen in the PAD sample of the synovia: synovial cellular lining was missing and substantial fibrin deposition was present along with a large number of perivascular lymphocytic cuffs. In the samples of the other patients, moderate to high amounts of metal particle laden macrophages were seen with a variable fibrin deposition and tissue degeneration.

One male patient (one hip) with 51/58 mm ASR components was operated on again due to severe heterotopic ossification. Metal ion levels were normal (Cr: 1.7 µg/l, Co: 1.9 µg/l) and MRI did not reveal any soft tissue lesions.

The seven-year survival rate for the whole patient cohort was 90.5% (95% CI 85.9% to 95.1%) with revision for any reason as the end-point (Figure 17).

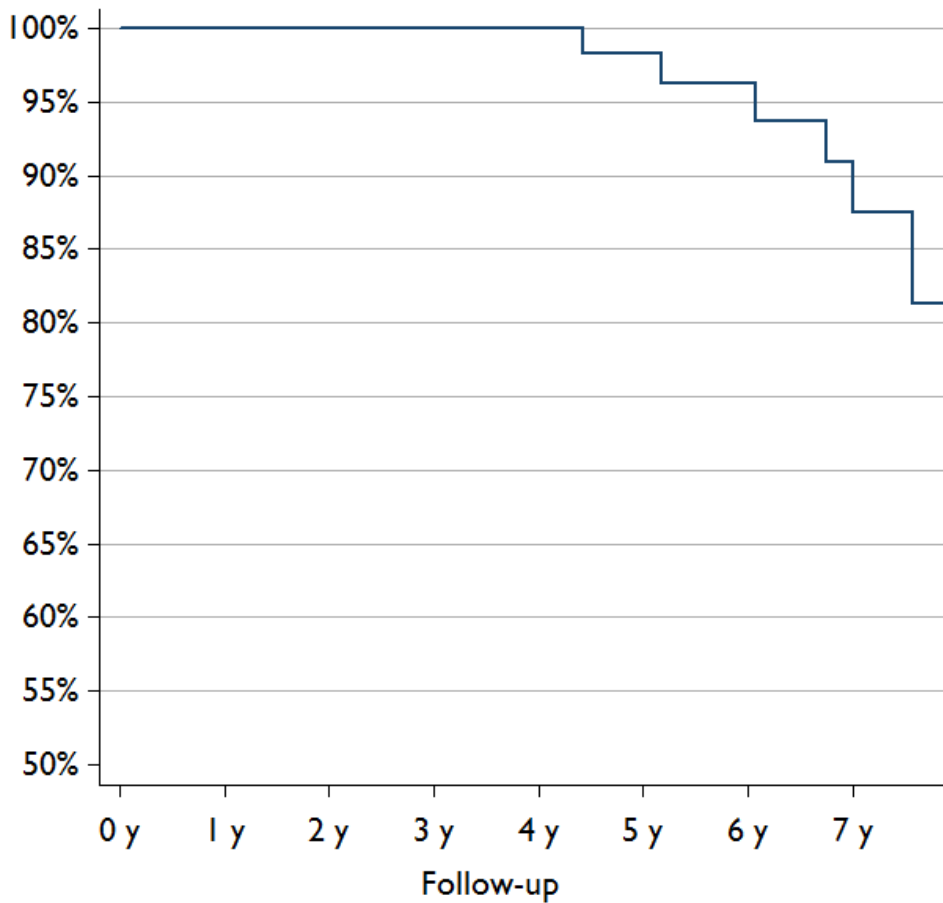

Figure 18. Kaplan-Meier survival curve for the whole cohort (75 hips) with any revision as the end-point.

5.3.2 Clinical results

Median HHS was 59 points (range 30 to 85) preoperatively, and increased significantly after the operation, with a median of 100 points (71 to 100, $p < 0.01$) at the one-year follow-up examination, and 98 points (53 to 100, $p < 0.01$) at the final follow-up evaluation.

Of the 48 non-revised patients 26 (54.2%) reported they were pain-free and the other 20 (41.7 %) patients reported occasional mild pain. Two patients (8.3%) were suffering occasional, moderate pain in the operated hip. The mean value for UCLA activity was 8.1 (range 4 to 10).

Of the 46 patients 25 (54.3%) reported excellent, 19 (41.3%) good and two (4.3%) fair subjective satisfaction at the time of the last follow-up. In the RAND-36 -questionnaire physical functioning and general health were 87.7 and 70.4 respectively. Men scored 87.9 points and women 87.3 points on average for physical functioning. General health was 68.8 and 73.7 respectively. Patients with comorbidities experienced lower activity level and poorer general health and physical functioning than those without comorbidities (Table 20).

	Patients without comorbidities	Patients with a comorbid condition	p-value
Median UCLA (range)	9 (4 to 10)	5 (2 to 7)	<0.01
Median HHS (range)	100 (65 to 100)	84.5 (53 to 86)	0.02
Median RAND 36 – scores (range)			
Physical functioning	95 (70 to 100)	67.5 (25 to 95)	<0.01
Physical role	100 (50 to 100)	50 (25 to 100)	<0.01
Mental role	100 (33 to 100)	100 (67 to 100)	0.8
Energy	80 (30 to 100)	57.5 (5 to 100)	0.042
Emotional well-being	80 (36 to 100)	68 (44 to 100)	0.11
Social functioning	100 (25 to 100)	76.5 (38 to 100)	0.08
Bodily pain	90 (45 to 100)	50 (23 to 68)	<0.01
General health	80 (25 to 100)	32.5 (25 to 45)	<0.01

Table 20. Comparison of outcome variables between patients without comorbidities and patients with comorbidity.

One patient sustained incomplete peroneal nerve palsy with complete recovery. In another patient there was a superficial infection due to a suture fistula which was treated by two courses of intravenous antibiotics.

5.4 Study IV

5.4.1 Cumulative survival and revisions

Of the 424 patients with 482 ASR hip replacements with femoral size of less than 50 mm (Study IV), 162 hips in 131 patients had undergone revision surgery (including those revised before the screening program). This represented 16% of

the population of ASR arthroplasties with femoral diameter of 50 mm or less we performed, at a mean of five years.

Adverse reactions to metal debris were diagnosed in the majority (n = 138 [85%]) of these revisions (Table 21). The prevalence of adverse reactions to metal debris was 31% in the ASR™ XL THR group and 25% in the HR group.

Cause of failure	Cohort		p-value
	Hip resurfacing	THR	
ARMeD	42 (84%)	96 (86%)	0.21
Infection	1 (2%)	9 (8%)	0.18
Aseptic loosening			0.7
Cup	3 (6.0%)	3 (2.7%)	
Stem	-	1 (0.9%)	
Avascular necrosis	1 (2.0%)	-	0.35
Periprosthetic fracture	2 (4.0%)	1 (0.9%)	0.28
Pain (without ARMeD)	2 (4.0%)	1 (0.9%)	0.28
Total	51(100%)	111 (100%)	0.27

Table 21. Causes of revisions in ASR™ hip resurfacing and THA cohorts

Cumulative seven-year survival rate was 51% (95% CI, 45%-57%) for the HR group and 38% (95% CI, 33%-44%) for the THR group with any revision as the end point respectively (p = 0.001) (Figure 19). With revision for ARMeD as the end point, the cumulative six-year survivorship was 73% (95% CI, 69%-78%) for the HR group and 61% (95% CI, 67%-65%) for the THR group at six years, respectively (p = 0.003).

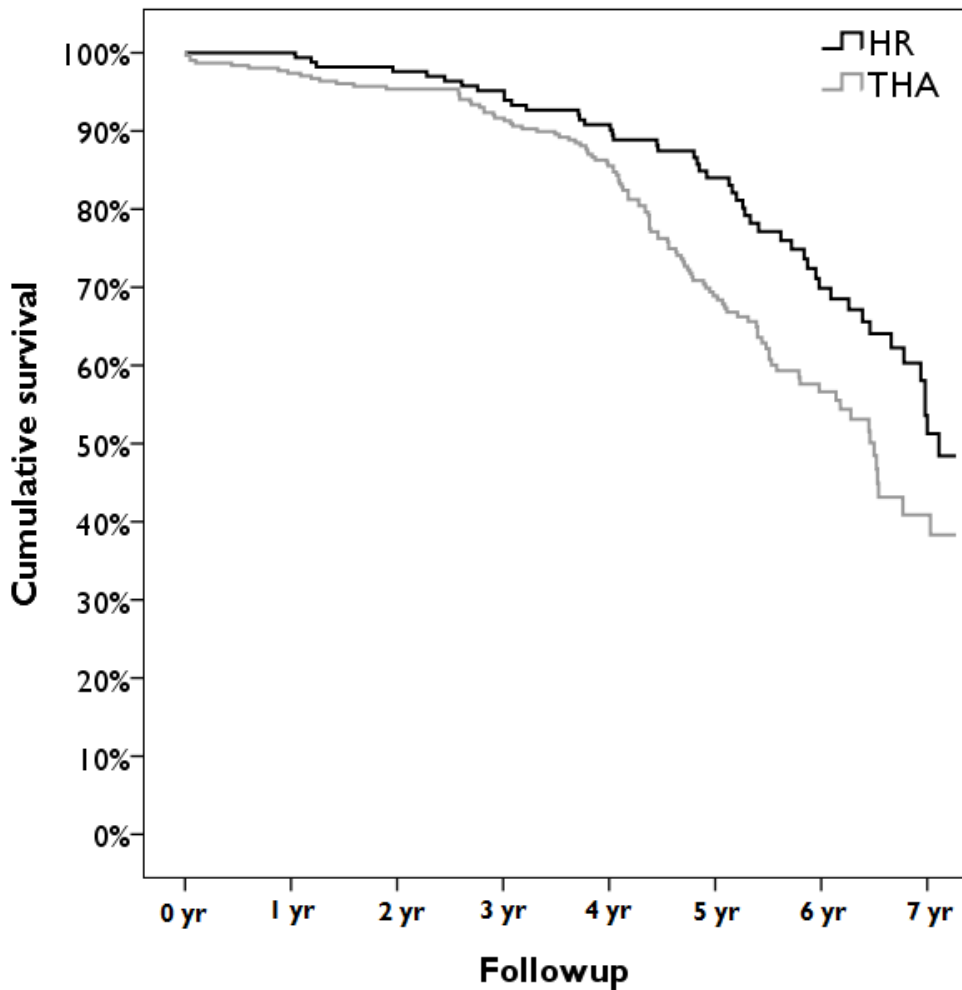

Figure 19. The overall survivorship for ASR hip resurfacing (HR) and THA cohorts with any revision as the end point.

5.4.2 Risk factors for ARMeD

Reduced cup coverage (THA cohort, $p < 0.001$; HR cohort, $p = 0.019$) was an independent risk factor for adverse reactions to metal debris in the THR cohort (Table 22) and HR cohort (Table 23). High preoperative ROM (risk ratio 1.92, $p = 0.04$), use of the Corail[®] stem (risk ratio 1.86, $p = 0.03$), and female gender (risk ratio 2.79, $p = 0.003$) were associated with an increased risk of adverse reactions to metal debris only in patients undergoing THR (Table 22).

The variance inflation factor ranged from 1.137 to 1.450 in the THR group and from 1.057 to 1.219 in the HR group implying that there is not a considerable amount of collinearity between predictor variables.

		Unadjusted RR (95% CI)	Adjusted RR (95% CI)
Age	<50 years	1.0	1.04 (0.44 to 2.46)
	≥50 years	1.81 (0.96 to 3.42)	1.0
Sex	Male	1.0	1.0
	Female	3.23 (1.76 to 5.95)**	2.79 (1.43 to 5.42)**
Diagnosis	OA	1.71 (1.08 to 2.72)*	1.32 (0.71 to 2.42)
	Other	1.0	1.0
Stem	Summit	1.0	1.0
	Corail	1.87 (1.12 to 3.15)*	1.86 (1.10 to 3.16)*
	Other	1.01 (0.44 to 2.32)	1.20 (0.45 to 3.18)
Preoperative ROM	<110°	1.0	1.0
	≥110°	1.93 (1.09 to 3.41)*	1.92 (1.08 to 3.44)*
Cup coverage	<25°	2.32 (1.54 to 3.50)**	2.17 (1.41 to 3.34)**
	≥25°	1.0	1.0
Femoral diameter	2mm decrement	1.02 (0.92 to 1.14)	1.10 (0.98 to 1.24)
AI	<50°	1.0	
	>50°	2.03 (1.35 to 3.06)**	N/A

Table 22. Risk factors for ARMeD in the THR group. RR = risk ratio, CI = confidence interval, N/A = not included in the analysis. * Indicates significant risk ratio (p<.05). ** Indicates significant risk ratio (p<.01)

		Unadjusted RR (95% CI)	Adjusted RR (95% CI)
Age	<50 years	1.0	1.34 (0.49 to 2.08)
	≥50 years	1.03 (0.54 to 1.96)	1.0
Sex	Male	1.0	1.0
	Female	5.57 (0.76 to 40.5)	2.35 (0.29 to 19.0)
Diagnosis	OA	1.75 (0.69 to 4.48)	1.71 (0.58 to 4.98)
	Other	1.0	1.0
Preoperative ROM	<130°	1.0	1.0
	≥130°	1.77 (0.88 to 3.55)	1.98 (0.97 to 4.03)
Cup coverage	<25°	1.79 (0.95 to 3.39)	2.22 (1.16 to 4.29)*
	≥25°	1.0	1.0
Femoral diameter	2 mm decrement	1.18 (1.01 to 1.40)*	1.21 (0.99 to 1.46)
AI	<50°	1.0	
	>50°	1.80 (0.97 to 3.35)	N/A

Table 23. Risk ratios for ARMeD in the HR group. RR = risk ratio, CI = confidence interval, N/A = not included in the analysis. * Indicates significant risk ratio (p<.05). ** Indicates significant risk ratio (p<.01)

5.4.3 Clinical results

Patients with THRs had significantly higher WB Co levels than patients with HR (Table 24). This difference was evident in patients with unilateral (p = 0.002) and bilateral (p < 0.001) hip arthroplasties. However, there was no difference in chromium levels between the HR and THR cohorts (Table 24). WB chromium and/or Co level exceeded 7 ppb in 18% of patients who had unilateral HR and in 37% of patients who had unilateral THR. A pseudotumour was found in 42 (10%) hips in cross-sectional imaging (Table 24). There were no differences in clinical scores between the HR and THR cohorts (Table 24).

Variable	Cohort		p value
	HR	THA	
Mean followup (range)	5.3 years (0.2-8.1)	4.6 years (0.2-8.0)	< 0.001
Median HHS (range)	94 (59-100)	94 (42-100)	0.89
Median OHS (range)	43 (11-48)	43 (12-48)	0.69
Median WB Co (range)			
Unilateral	2.3 ppb (0.7-217.7)	4.2 ppb (0.3-191.7)	0.006
Bilateral	2.4 ppb (0.9-96.9)	13.0 ppb (1.5-139.9)	0.002
Median WB chromium (range)			
Unilateral	2.0 ppb (0.8-94)	2.1 ppb (0.4-115)	0.58
Bilateral	2.7 ppb (1.0-54)	3.4 ppb (0.8-61)	0.28
Pseudotumor (proportion)			
MRI	12 (9.3%)	25 (10.4%)	0.87
US	1 (4.8%)	4 (12.9%)	0.39

Table 24. Clinical, laboratory, and cross-sectional imaging findings of patients attending the screening programme

6 Discussion

6.1 Assessment of cup orientation

6.1.1 Inaccuracies with plain radiographs

Pelvic rotation and pelvic tilt are the major causes of inaccuracy in the measurement of version between subsequent radiographs. Tannast et al. (2006) measured six different parameters to estimate pelvic tilt and rotation. The best correlation with pelvic tilt was 0.68 for men and 0.63 for women. Most importantly the inaccuracy due to the pelvic tilt or pelvic rotation can be minimized by organized and systematic imaging procedure. Imaging in supine position should be avoided since the difference between measured version in supine and standing position may be 20 degrees at most (Eddine et al 2001). It should also be remembered that when using plain radiographs in the assessment of the cup orientation retroverted cup cannot be excluded by a simple AP radiograph. Care should be taken when embracing calculated version as anteversion, regardless of method used.

Due to centering of the x-ray beam to the pubic symphysis the acetabular cup component is imaged obliquely in whole pelvis radiographs (Widmer 2004, Derbyshire 2008), so the cup opening is imaged obliquely. In CT the cup opening is seen directly in anteroposterior direction and this causes differences in calculations assuming the parallelism of the coronal and McKibbin plane. Derbyshire (2008) proposed a way to estimate this error and to correct the calculated version. Widmer on the other hand proposed a correction of the version by 5.46 degrees when the imaging distance is 1.15 metres. Pradhan (1999) preferred correction of 5 degrees.

We did not implement any correction arising from the obliqueness of the imaging. Thus we ignored the terms true and anatomical version. Mainly this was due to fact that we did not aim to validate this method against the golden standard, which most likely is the computer tomography based method. More importantly, we aimed to study the usefulness and repetitiveness of our method.

6.1.2 Usefulness of assessment based on plain radiographs

The limits of agreement between and correlations among and within observers were satisfactory. Therefore we conclude that our method is suitable for the assessment of cup version in MoM HRs.

A major limitation in Study II was the lack of comparison to another method. Computer tomography imaging is often considered to be the gold standard in the determination of the version of the cup component in hip arthroplasty (Marx et al. 2006, Kalteis et al. 2006). We, however, argue that CT should have been used as gold standard to compare measurements obtained with our method. Mainly we base this on the fact that plain radiographs and CT have different premises in the assessment of version. The former defines the planar values and the latter the true or anatomical values. Cup orientation in relation to the coordinate system based on the bony hip can be measured with CT and planar orientation of the cup is calculated from plain radiographs. An important principle is that radiographic version should equal CT based version if the reference plane is coronal. This is highlighted by the fact that with fixed anteversion the correlation between pelvic tilt and measured anteversion is linear (Haenle et al. 2007).

Marx et al. (2006) compared measurements done with five different radiographic methods and CT. The method proposed by Widmer (2004) produced nine degrees greater values than the other four radiographic methods. The values calculated by methods other than Widmer's were within 0.2 degrees. The difference was probably due to correction of 5.46 degrees which is included in the method by Widmer. The correction value is affected by the imaging distance, which in Widmer's method is 1.15 metres. The difference between values obtained using Widmer's method and CT was -6.4 degrees, i. e. CT produced greater values. The difference between the other four methods and CT based measurements varied between -14.3 and -14.5 degrees.

In the study by Mayr et al. (2005) the mean inclination of the pelvis or pelvic tilt in the standing position was 6.7 degrees among 120 patients when the McKibbin plane was used as the reference. As noted, with fixed anteversion the correlation between pelvic tilt and measured anteversion is linear (Haenle et al. 2007). If the pelvic tilt of 6.7 degrees is corrected so that the McKibbin plane matches the coronal plane, the radiologically estimated cup version is increased by a value which can be calculated precisely, as described by Murray (1993). More specifically, if a pelvic tilt of 6.7 degrees with a fixed radiographic inclination of 45 degrees is transformed to planar (radiographic) values according to Murray (1993), radiographic version is increased by 4.7 degrees. If this transformation is applied to

the findings of Marx et al. (2006) and also taking into account the correction due to the obliqueness of the planar imaging, the differences between radiographic and CT measurements are essentially decreased.

Hence, we believe that any radiological assessment is important and useful and that our method is valid to assess cup orientation in LD-MoM HRs. Especially for investigational purposes the plain radiograph based method is more appropriate if there are a hundred or more cases since our method, along with others, is easy to conduct and is inexpensive compared to CT. Moreover, it is debatable if it is truly worthwhile to assess the true, anatomic version of the cup. For investigative purposes it is often more important to study the significance of extremes of version instead of certain absolute cut-off values, i.e. correlational statistics are preferable to inferential statistics. To conclude, we acknowledge that our method has the same disadvantages as other radiological methods. However, we believe our method, which is based on plain radiographs, is suitable for use with contemporary hemi- or subhemispherical metal cups mindful of the different premise of assessment compared to CT.

6.2 Birmingham Hip Resurfacing

6.2.1 Aetiology of failure

Neck fracture and aseptic loosening of femoral or acetabular component are the most common reasons for failure in HRs in the Australian joint registry (AOANJRR 2013). Carrothers et al. (2010) reported 181 revisions among 5,000 BHRs neck fractures (54 hips) and cases of aseptic loosening (32 hips) to be the most common reason for failure. Aseptic loosening did not occur among our patients. In the literature, aseptic loosening has been more prevalent in female patients (Carrothers et al. 2010). Several authors have attributed this to increased wear leading to osteolysis and subsequent component loosening (Carrothers et al. 2010, McMinn 2011). Hence the absence of component loosening in our cohort may be due to matters of definition. In the presence of metallosis, synovitis and/or PT we defined ARMeD as the cause of failure regardless of component fixation. We consider this more profound since ARMeD as a cause of failure has been shown to lead to significantly poorer post-revision outcome (Grammatopoulos et al. 2009).

We encountered four neck fractures among our patients. There are two important observations regarding neck fractures in our study. Firstly, proportion of neck fractures of all failures was significantly smaller in our study compared to that of Carrothers et al. (2009). We attribute this finding to the high prevalence of ARMeD seen in our study, since Carrothers reported only 15 cases (out of 181) of ARMeD. In our cohort ARMeD accounted for 11 out of 23 revisions. One suspected ARMeD was pending. A similar proportion of neck fractures and ARMeD was seen in the study by Murray et al. (2012), who reported ten-year results of 646 BHRs. Both in our cohort and in the study by Murray et al. special attention was paid to diagnosis of ARMeD. This likely explains the higher prevalence of ARMeD.

The second observation regarding neck fractures in our cohort was the time between index operation and failure. In the study by Carrothers et al. (2010) mean time to failure was 0.65 years in males and 2.7 years in females. Steffen et al. (2009) analysed the prevalence and risk factors for neck fracture in a patient group containing 822 patients (842 hips). No significant risk factors were identified but a retrieval analysis of 11 fractured hips showed necrosis in nine cases. All these cases had occurred during the first three postoperative months. In a later study these scholars found that avascular necrosis was the underlying cause for neck fracture (Steffen et al. 2010). Furthermore, Beaulé et al. (2006) showed that femoral neck notching leads to a reduction in blood flow to the femoral head in extraosseous veins predisposing to avascular necrosis. Hence notching along with undersizing of the femoral component are important risk factors for neck fracture. Neck fractures in our cohort occurred at 2.0, 5.5, 6.6 and 7.8 years postoperatively. This is considerably later than the time to failure reported by Carrothers et al. (2010). Hence we conclude that the surgical technique damaging the extraosseal blood supply to the head was probably not the cause of failure in our patients.

6.2.2 Cumulative survival

The five to eight-year survival of 96.7% in our smaller BHR cohort is comparable those to seen in other patient series from independent centres with a mean follow-up of five to six years (Hing et al. 2007, Heilpern et al. 2008, Steffen et al. 2008, Khan et al. 2009). Eskelinen et al. (2005) reported the results of THR in patients aged 55 years or younger diagnosed with OA according to the Finnish Arthroplasty Register. The seven-year cumulative survival rate of 1,893 proximal porous-coated uncemented stems and 1,999 porous-coated press-fit uncemented

cups implanted between 1991 and 2001 was 95% for each component separately. Our results were superior to these results.

Ten-year survival in male patients in our study is slightly inferior to survival rates reported earlier, but still meets the criteria set by NICE in the UK (National Institute of Health and Care Excellence) (Table 25). In females the variance in survival is greater in earlier studies. Our result is comparable to those reported recently by other independent centres (Coulter et al. 2012, Holland et al. 2012, Murray et al. 2012). Murray and co-workers (2012) performed cross-sectional imaging on patients with OHS less than 33 points. This may explain the poorer survival in female patients in that study. In their study 48% of revisions were due to ARMeD. In the two other studies ARMeD was the cause of failure in 18% and 25% of the revisions (Coulter et al. 2012, Holland et al. 2012). In our cohort 48% of revisions were due to ARMeD. In male patients ARMeD accounted for 30% of revisions and in females 62%. The stricter screening is likely to affect the somewhat inferior survival and higher prevalence of ARMeD observed in our study. In all other studies the patient selection for imaging was presumably based solely on symptoms. In none of the other studies have WB metal ion levels been routinely measured. Further follow-up will reveal whether pseudotumours and revisions due to ARMeD continue to occur after follow-up exceeding ten to eleven years.

Study	Males		Females	
	Patients (hips)	10-year survival (95% CI)	Patients (hips)	10-year survival (95% CI)
Our study	128 (148)	93.1% (91.0% to 95.2%)	61 (73)	86.0% (82.1% to 89.9%)
Coulter et al. (2012)	140 (nr)	97.5% (92.4 to 99.2)	73 (nr)	89.1% (79.2 to 94.4)
Holland et al. (2013)	68 (74)	94.6% (89.4 to 100)	22 (26)	84.6% (70.7 to 98.5)
Murray et al. (2012)	325 (379)	95% (92.0 to 97.4)	229 (267)	74% (83 to 91),
Matharu et al. (2013)	nr (195*)	100% (100 to 100)**	nr (109*)	96.1% (90.1 to 99.9)**

Table 25. Recent studies reporting 10-year survival of BHR. nr = not reported. * = patients aged <50years, ** = aseptic revisions only

6.2.3 Routine metal ion measurement

In our cohort there were twelve patients with no complaints in the operated hip(s) but with elevated WB metal ion levels. According to the current guidelines, these patients would not have been imaged. However, according to our screening protocol cross-sectional imaging was performed and a pseudotumor was detected in five patients. Eight patients had elevated WB metal ion levels and complaints in the operated hip. In five patients a pseudotumor was detected in cross-sectional imaging. This is no surprise, and besides, according to current guidelines these patients ought to undergo cross-sectional imaging. In addition, only three pseudotumors were observed in 28 patients with complaints in the hip but normal WB metal ion levels.

Thus, in our opinion it is beneficial to combine routine metal ion measurement with clinical assessment. It helped us to identify several patients needing close surveillance in the future. Moreover, Chang et al. (2012) reported that pain is more likely attributable to muscle atrophy than the presence of PT. Several pseudotumours in our study would have gone unidentified if clinical symptoms had been the only indication for imaging. We continue to perform WB metal ion measurements also on patients with MoM devices with a good clinical track record.

6.2.4 Limitations

We acknowledge a few limitations in our study. Firstly, in most of our patients WB metal ion assessment was performed only once and the decision to perform cross-sectional imaging was therefore taken at a single time-point. Natural deviation of WB metal ion levels is unknown and, for example, the results regarding their association with activity are controversial (Heisel et al. 2005, Khan et al. 2008). WB metal ion measurements are performed on a regular basis in our follow-up programme (annually or biennially) and from now on special attention and cross-sectional imaging will be targeted at patients with a tendency for rising WB metal ion levels and/or exacerbating hip symptoms. Secondly, we used a cut-off value for elevated metal ion which was based on an earlier study reporting the diagnostic value of WB metal ions (Hart et al. 2011). We used the same cut-off value for all patients and we did not differentiate between unilateral and bilateral patients. Different safe upper limits for unilateral and bilateral HR patients have been proposed (Van Der Straeten et al. 2012). In our opinion one cut-off value for the screening and follow-up of patients is more straightforward and preferable in

clinical work. Furthermore, we did not aim to establish screening guidelines but to investigate the current recommendations.

Thirdly, the interpretation of our results is influenced by the large number of non-BHR-MoM implants in unilateral BHR patients. Especially in Group 2 a relatively high proportion of unilateral BHR patients had some other MoM implant. Two of three PTs seen in this group were in patients with only the unilateral BHR present. Furthermore, two of the five patients with non-BHR implants were resurfacing implants (the other two being ASR and LD-MoM THA) and not subjected to routine WB metal ion measurement according to current guidelines. Therefore we consider our conclusion regarding routine WB metal ion measurement justified. Fourthly, we acknowledge that there may have been patients with PT who are asymptomatic and have non-elevated WB metal ion levels since we did not image these patients. However, our aim was not to establish the overall incidence of ARMED. Instead we aimed to study the usefulness of the current guidelines in the screening of patients with a MoM HR with good clinical track records.

6.3 HR in patients aged 40 or less

6.3.1 THA versus HR

In the literature there has been debate about the superiority of MoM HR over MoM THR. Both randomized controlled trials (RCT) and case-control studies have been conducted comparing these two designs but no significant differences have been established between them (Garbuz et al. 2010a, Lavigne et al. 2010, Mont et al. 2009). No RCT's have been performed on patients with mean age less than 50 years.

6.3.2 Cumulative survival and revisions

The survival rate of HR in our cohort was relatively poor, being 90.5% only at seven-year follow-up. There were not sufficient hips to examine the survival separately for genders. All other studies reporting survival after HR in patients aged 40 or less have shown superior survival to ours (Sayeed et al. 2010, Krantz et al. 2012, Woon et al. 2013). In three studies with a total number of 97 hips no cases of ARMED were reported. Our results were very different; seven out of eight

revisions were due to ARMeD. Five out of seven patients with ARMeD had PT identified in pre-revision cross-sectional imaging.

There are, however, several important observations regarding the high prevalence of ARMeD seen in our study. Firstly Conserve was the most common hip device used in other studies reporting the results of HR in patients under age 40 (Sayeed et al. 2010, Krantz et al. 2012, Woon et al. 2013). Conserve implant has shown very low prevalence of ARMeD (Langton et al. 2011). By contrast, the now recalled ASR device was commonly implanted in our patients and five out of seven patients with ARMeD had an ASR implant. Secondly, two patients with ARMeD having a BHR implant had an inclination angle of 55 degrees or more. One of these patients also had a femoral diameter of 42 mm and hence they were at risk of high wear and ARMeD specifically due to small cup coverage (Griffin et al. 2010).

6.3.3 Clinical outcome and quality of life

We assessed the quality of life with the RAND-36 questionnaire. For the RAND-36 questionnaire normative data for unselected Finnish population has been established (Aalto et al. 1999). In our study physical functioning for men was 87.9 and for women 87.3. The average values for Finnish subjects aged 30-34 were 94.2 and 93.3 for men and women respectively (Aalto et al. 1999). When only patients without comorbidity are considered, the corresponding values were 91.5 and 93.1 respectively. The general health of our patients was 68.8 among men and 73.7 among women. Even higher numbers were seen when patients without comorbidities were considered. For Finnish subjects the corresponding values for those aged 30-34 were 69.3 and 73.3. This is probably because comorbidity is low among young patients. It seems that in young patients with isolated hip disease, MoM HR can restore their general health to the level of general population.

6.3.4 Activity and survival

Young patients have both preoperatively and, more importantly, postoperatively high activity levels as also seen in our study. In a recent study by Le Duff and Amstutz (2012) high level of activity was associated with inferior long-term survival of MMHR. Prevalence of ARMeD is known to be associated with high metal ion concentrations in blood (Langton et al. 2010). Few reports have addressed the correlation between patient activity and blood metal ion levels and the results have been inconclusive. Khan et al. (2008) reported a moderate correlation between exercise-related Co increase and acetabular inclination. In

another study no significant elevation of circulating metal ions after exercise was observed (Heisel et al. 2005).

However, our results raise concern regarding a possible correlation between high patient activity and ARMeD. Five out of seven patients revised due to ARMeD had inclination over 50 degrees and thus reduced cup coverage. This does not, however, directly lead to increased metal ion release, as seen in earlier studies (De Haan et al. 2008, Hart et al. 2011). Metal surfaces in the HR are referred to as tribomaterials which have been shown to form a layer with nanocrystalline grain size or tribolayer *in vivo* in the cup-head interface (Catelas and Wimmer 2011). This tribolayer is thought to dissipate frictional energy by grain rotation in the nanocrystalline layer enabling very low wear rate. However, such a tribolayer has been shown to be absent in high-stress conditions (i.e. stripe-wear regions and scrapings due to microseparation), which leads to increased wear (Catelas and Wimmer 2011). Patients under 40 do not necessarily have higher post-operative hip range-of-motion but they do experience higher periarticular muscle forces and a very active life style which may cause forceful head to rim contacts and other stress-related wear patterns. It is reasonable to assume that optimal MoM bearing conditions (i.e. continuously present tribolayer and therefore ultra-mild sliding regime) do not prevail in very young and active patients. Hence, very active patients may be more prone to wear related adverse outcomes if there is no optimal cup coverage. To date no simulator study has been performed with this hypothesis.

6.3.5 Limitations

We concede several shortcomings in our study. Our mean follow-up was not long enough to detect all ARMeD patients, since the time to revision due to ARMeD may be as long as nine years. Furthermore, systematic metal ion level screening or cross-sectional imaging was not performed on all patients, meaning that there may be asymptomatic ARMeD cases among our patients. Further, lack of preoperative UCLA and RAND-36 data limits the interpretation of our results. However, we prospectively followed up an unselected consecutive series of extremely young MMHR patients.

6.4 ARMeD with patients operated on with ASR hip replacement

6.4.1 Prevalence and risk factors

In ASR patients the prevalence of adverse reactions to metal debris was higher than that reported by Langton et al. (2011). In their study, the prevalence was 14% in the HR group and 29% in the THR group. Survival rates in our study were also inferior to those reported by Langton et al. (2011). We believe this is because our cohort included only patients with a small femoral head size, meaning that our patients were more prone to edge-loading as a result of a reduced FA (Griffin et al. 2010). Therefore, failure resulting from increased wear originating from the bearing surface instead of the taper is likely to be more prevalent in our cohort.ok

We examined risk factors for adverse reactions to metal debris and found that reduced cup coverage was strongly associated with an increased risk of adverse reactions in HR and THR cohorts. Small head diameter, by contrast, did not directly lead to an increased prevalence of adverse reactions. In our cohort, there were 32 resurfaced small-headed hips with cup coverage greater than 35°, and only two of these (6.3%) were revised. Reduced cup coverage was also a significant risk factor for adverse reactions to metal debris-related failure in the THR cohort. Therefore taper damage or taper corrosion appears not to be solely responsible for the high prevalence of adverse reactions in patients who received the ASR™ XL prosthesis during THA.

In the Study IV, patients who received a HA-coated Corail® stem in the primary THR were found to be at significantly higher risk for adverse reactions to metal debris-related failure. As Summit® and Corail® stems have identical 12/14 tapers, the wear or corrosion process in the taper-trunnion junction should not differ between them. The marked difference between these stem designs is their coating; whereas the Corail® stems have a HA coating, the Summit® stems are proximally porous-coated. HA coating has been shown to degrade over time and result in HA flake release and presumably third-body wear (Rokkum et al. 2002). This being the case, the problem with the Corail® stem goes beyond the ASR™ bearing system and the higher than expected failure rate also should be seen with other MOM bearing systems coupled with a Corail® stem or other HA-coated stem designs. Confirmation of the reason for this finding warrants additional research necessitating clinical and retrieval analyses.

It is also noteworthy that the survival rates in the Australian registry concur with our results (AOANJRR 2012). Corail® stem coupled with ASR acetabular component has a higher revision rate than that of Summit stem coupled with ASR cup. Moreover, Corail stem coupled with Pinnacle® (DePuy, Warsaw, IN, USA) acetabular component has a higher revision rate than that of Summit® stem coupled with Pinnacle® acetabular component.

Risk factors associated with adverse reactions to metal debris in larger head sizes may differ from those established in our study with small-heads. The FA of the cup increases with increasing head sizes thus offering more cup coverage and reducing the occurrence of edge-loading (Griffin et al. 2010). Thus, especially in patients with large head implants in HR, the prevalence of adverse reactions may be lower than in our current cohorts. Owing to increased cup coverage with larger head sizes, other factors may be more influential in the development of adverse reactions to metal debris.

6.4.2 Limitations

A major limitation in our study was inadequate assessment of cup orientation. Extremes of cup version are known to be associated with an increased risk of adverse reactions to metal debris-related failure. We did not calculate cup version in this study because we lacked appropriate tools to measure version accurately. We also included patients with unilateral and bilateral hip arthroplasties. It is debatable whether it is appropriate to include bilateral implants in survival analyses. It can be assumed that patients who received bilateral implants and have experienced possible metal hypersensitivity-related failure on one side are also at an increased risk of failure of the other hip for the same reason, even if the components were properly implanted. Furthermore, it is debatable whether the systemic exposure of metal ions affects the contralateral hip. This may cause unobserved heterogeneity and it could be addressed by acquiring a shared frailty model in regression analysis. We did not use a shared frailty model as a result of the small number of bilateral revisions owing to adverse reactions to metal debris (six patients).

Finally, we studied only one implant with a known design flaw that predisposes the bearings to edge-loading and the patients with these hip replacements to adverse reactions to metal debris. Most likely this is the reason why the ASR™ implant has been withdrawn from the market. However, several facts suggest that these results can most likely be generalized to other MOM implants as well. First, the design flaw of the ASR™ prosthesis (i. e. poor cup coverage) was only one of

the risk factors for adverse reactions to metal debris: the effects of high ROM and gender, for instance, are not implant-dependent. Second, adverse reactions to metal debris are seen with all implant types, and approximately 50% of failures of MOM hip implants have low wear rates of the bearing surfaces.

7 Conclusions

- I. Our results along with other published studies have shown encouraging results regarding mid-term survival after BHR. However, further research is warranted to ascertain the true incidence and prevalence of ARMeD in patients with MoM HRs, and also whether survival remains at an acceptable level for up to 15 years of follow-up. Only then can one estimate whether MoM HR will remain a viable option in the treatment of hip OA in young and active patients.
- II. The mathematical method presented to assess the version and inclination of the cup in the MoM bearing shows that the limits of agreement and the mean errors between observers were at an acceptable level. Moreover, this method is also applicable to any orthopaedic templating software. The observations clearly demonstrated the necessity of mastering the technique as evinced in nonconforming results in one of the measurement series done without previous experience with the software in question.
- III. MoM HR achieved excellent functional medium-term outcome in young patients aged 40 or less. There were no femoral neck fractures, or aseptic loosening of either component, which is likely attributable to the benefit of a high-volume clinic. On the other hand, cumulative survival was not satisfactory since it decreased to 90% in just less than seven years.
- IV. We found a high rate of revision attributable to adverse reactions to metal debris in patients with ASR HR and XL THR. We found several significant risk factors for adverse reactions in patients who had received ASR™ XL THAs; namely, female gender, stem type (Corail®), high preoperative ROM ($> 110^\circ$), and reduced cup coverage ($< 25^\circ$), the last being a risk factor for adverse reactions in the HR cohort as well. Our results suggest a more complicated failure mechanism in THAs than in hip resurfacing procedures.

- V. Ten year survival of BHR was satisfactory in male patients after systematic screening for ARMeD. Moreover, our results suggest that WB metal ion measurement is also useful follow-up tool in asymptomatic patients with an HR device. This finding conflicts with the current international guidelines. In addition to having aided us in identifying patients with ARMeD, routine WB metal ion measurement also helped us to identify patients in need of closer surveillance.

Acknowledgements

This study was carried at the Coxa Hospital for Joint Replacement and the University of Tampere, Finland.

Above all I want to thank my supervisors Docent Antti Eskelinen, MD, PhD and Docent Timo Puolakka, MD, PhD. Their guidance and support created an excellent and relaxed environment to carry out this dissertation. Furthermore, their enthusiasm for science and open-mindedness in relation to new research ideas have encouraged me to continue to conduct orthopaedic research in the Coxa study group.

I wish to express my appreciation to Docent Jorma Pajamäki, MD, PhD. At his instigation in the early phases of my medical studies I worked as a study intern and was introduced to orthopaedic research and surgery. He also played an important role in guidance and planning throughout my thesis.

I want to thank Professor Heikki Kröger, MD, PhD and Docent Hannu Miettinen, MD, PhD for their valuable contribution in reviewing my thesis and for their constructive criticisms and during the preparation of the final work.

During the early stages of this work it was my good fortune to work at the Coxa hospital. I wish to thank Jorma, Timo, Antti and the other Coxa surgeons for their positive attitude and collaboration.

I want to express my gratitude to Ella Lehto (research nurse) for her excellent work. Towards to the end of my dissertationproject there have been a countless number of data sources. Ella's work was of great importance in sorting this data out and making it available to researchers, including me.

I warmly thank Petra Elo M.D., PhD and Docent Antti Paakkala MD, PhD for their critical comments and for co-authoring the original articles. I also thank Heini Huhtala MSc for her statistical assistance.

For the valuable friendship I owe my thanks to my closest friend Samppa, who tragically died in an aviation accident in autumn 2014. Samppa was always there to divert my attention to things outside work and to remind to live life to the fullest. I am grateful to my mother and father-in-law for their care, endless support and limitless understanding during my academic years.

This study was financially supported by the Finnish Arthroplasty Association, the Finnish Research Foundation for Orthopaedics and Traumatology and the Medicare Foundation.

References

- Aalto, A.M. Aro, A.R. Teperi, J. (1999) RAND-36 terveyteen liittyvän elämänlaadun mittarina: Mittarin luotettavuus, suomalaiset väestöarvot. STAKES Tutkimuksia 101
- Ackland MK, Bourne WB, Uhthoff HK. (1986) Anteversion of the acetabular cup. Measurement of angle after total hip replacement. *J Bone Joint Surg Br* 68:409-13.
- Adelani MA, Keeney JA, Palisch A, Fowler SA, Clohisy JC. (2013) Has total hip arthroplasty in patients 30 years or younger improved? A systematic review. *Clin Orthop Relat Res.* 471:2595-601.
- Amstutz HC, Thomas BJ, Jinnah R. (1984) Treatment of primary osteoarthritis of the hip: a comparison of total joint and surface replacement arthroplasty. *J Bone Joint Surg Am.* 66:228-41
- Amstutz HC and Grigoris P. (1996) Metal on metal bearings in hip arthroplasty. *Clin Orthop Relat Res* 329 Suppl:S11-34.
- Amstutz HC, Beaulé PE, Dorey FJ, Le Duff MJ, Campbell PA and Gruen TA. (2004) Metal-on-metal hybrid surface arthroplasty: two to six-year follow-up study. *J Bone Joint Surg Am* 86-A:28-39.
- Amstutz HC, Ball ST, Le Duff MJ, Dorey FJ. (2007) Resurfacing THA for patients younger than 50 year: results of 2- to 9-year followup. *Clin Orthop Relat Res.* 460:159-64.
- Amstutz HC, Le Duff MJ, Campbell PA, Gruen TA, Wisk LE. (2010) Clinical and radiographic results of metal-on-metal hip resurfacing with a minimum ten-year follow-up. *J Bone Joint Surg Am* 92:2663-71.
- Amstutz HC and Le Duff MJ. (2010b) Hip resurfacing results for osteonecrosis are as good as for other etiologies at 2 to 12 years. *Clin Orthop Relat Res* 468:375-81.
- Amstutz HC, Le Duff MJ, Campbell PA, Wisk LE and Takamura KM. (2011) Complications after metal-on-metal hip resurfacing arthroplasty. *Orthop Clin North Am* 42:207-227.
- Anderson H, Toms AP, Cahir JG, Goodwin RW, Wimhurst J, Nolan JF. (2011) Grading the severity of soft tissue changes associated with metal-on-metal hip replacements: reliability of an MR grading system. *Skeletal Radiol* 40:303-7.
- Anissian HL, Stark A, Gustafson A, Good V, Clarke IC. (1999) Metal-on-metal bearing in hip prosthesis generates 100-fold less wear debris than metal-on-polyethylene. *Acta Orthop Scand* 70:578-82.
- Aulakh TS, Rao C, Kuiper JH, Richardson JB. (2010) Hip resurfacing and osteonecrosis: results from an independent hip resurfacing register. *Arch Orthop Trauma Surg* 130:841-5.
- Australian Orthopaedic Association National Joint Replacement Registry. Annual Report 2008. <https://aoanjrr.dmac.adelaide.edu.au/annual-reports-2008>.
- Australian Orthopaedic Association National Joint Replacement Registry. Annual Report 2009. <https://aoanjrr.dmac.adelaide.edu.au/annual-reports-2009>.

- Australian Orthopaedic Association National Joint Replacement Registry. Annual Report 2012. <https://aoanjrr.dmac.adelaide.edu.au/annual-reports-2012>.
- Australian Orthopaedic Association National Joint Replacement Registry. Annual Report 2013. <https://aoanjrr.dmac.adelaide.edu.au/annual-reports-2013>.
- Back DL, Dalziel R, Young D, Shimmin A. (2005) Early results of primary Birmingham hip resurfacings. An independent prospective study of the first 230 hips. *J Bone Joint Surg Br* 87:324-9.
- Ball ST, Le Duff MJ, Amstutz HC. (2007) Early results of conversion of a failed femoral component in hip resurfacing arthroplasty. *J Bone Joint Surg Am* 2007;89:735-41.
- Bergeron SG, Desy NM, Nikolaou VS, Debiparshad K, Antoniou J. (2009) The early results of metal-on-metal hip resurfacing - a prospective study at a minimum two-year follow-up. *Bull NYU Hosp Jt Dis.* 67:132-4.
- Berton C, Girard J, Krantz N, Migaud H. (2010) The Durom large diameter head acetabular component: early results with a large-diameter metal-on-metal bearing. *J Bone Joint Surg Br.* Feb;92:202-8.
- Bisschop R, Boomsma MF, Van Raay JJ, Tiebosch AT, Maas M, Gerritsma CL. (2013) High Prevalence of Pseudotumors in Patients with a Birmingham Hip Resurfacing Prosthesis: A Prospective Cohort Study of One Hundred and Twenty-nine Patients. *J Bone Joint Surg Am* 95:1554-60.
- Blanchard. (2008) URGENT DEVICE CORRECTION. <http://www.zimmer.com/content/pdf/en-US/DUROM-SURGEON-LETTER-07-22-08.pdf>
- Bland JM, Altman DG (1986) Statistical methods for assessing agreement between two methods of clinical measurement. *Lancet* 8476;307-10.
- Boardman DR, Middleton FR, Kavanagh TG. (2006) A benign psoas mass following metal-on-metal resurfacing of the hip. *J Bone Joint Surg Br* 88:402-4.
- Bolland BJ, Culliford DJ, Langton DJ, Millington JP, Arden NK, Latham JM. (2011) High failure rates with a large-diameter hybrid metal-on-metal total hip replacement: clinical, radiological and retrieval analysis. *J Bone Joint Surg Br* 93:608-15.
- Bordini B, Stea S, De Clerico M, Strazzari S, Sasdelli A, Toni A. (2007) Factors affecting aseptic loosening of 4750 total hip arthroplasties: multivariate survival analysis. *BMC Musculoskelet Disord.* 24;8:69.
- Bose VC, Baruah BD. (2010) Resurfacing arthroplasty of the hip for avascular necrosis of the femoral head: a minimum follow-up of four years. *J Bone Joint Surg Br.* 92:922-8
- Bosker BH, Ettema HB, Boomsma MF, Kollen BJ, Maas M, Verheyen CC. (2012) High incidence of pseudotumour formation after large-diameter metal-on-metal total hip replacement: A prospective cohort study. *J Bone Joint Surg Br* 94:755-61.
- Bowsher JG, Hussain A, Williams PA, Shelton JC. (2006) Metal-on-metal hip simulator study of increased wear particle surface area due to 'severe' patient activity. *Proc Inst Mech Eng H.* 220:279-87.
- Breck LW. (1970) Preliminary report on total hip joint replacement with Urist-Thompson unit without cement. *Clin Orthop Relat Res.* 72:174-6.
- Brewster DH, Stockton DL, Reekie A. (2013) Risk of cancer following primary total hip replacement or primary resurfacing arthroplasty of the hip: a retrospective cohort study in Scotland. *Br J Cancer* 108:1883-90.
- Brooker AF, Bowerman JW, Robinson RA, Riley LH Jr. (1973) Ectopic ossification following total hip replacement. Incidence and a method of classification. *J Bone*

- Joint Surg Am. 55:1629-32. Browne JA, Bechtold CD, Berry DJ, Hanssen AD, Lewallen DG. (2010) Failed metal-on-metal hip arthroplasties: a spectrum of clinical presentations and operative findings. *Clin Orthop Relat Res* 468:2313-20.
- Busch V, Klarenbeek R, Slooff T, Schreurs BW, Gardeniers J. (2010) Cemented hip designs are a reasonable option in young patients. *Clin Orthop Relat Res.* 468:3214-20.
- Campbell P, Ebramzadeh E, Nelson S, Takamura K, De Smet K, Amstutz HC. (2010) Histological features of pseudotumor-like tissues from metal-on-metal hips. *Clin Orthop Relat Res* 468:2321-7.
- Carli A, Reuven A, Zukor DJ, Antoniou J. (2011) Adverse soft-tissue reactions around non-metal-on-metal total hip arthroplasty - a systematic review of the literature. *Bull NYU Hosp Jt Dis* 69 Suppl 1:S47-51.
- Carrothers AD, Gilbert RE, Jaiswal A, Richardson JB. (2010) Birmingham hip resurfacing: the prevalence of failure. *J Bone Joint Surg Br* 92:1344-50.
- Catelas I, Wimmer MA. (2011) New insights into wear and biological effects of metal-on-metal bearings. *J Bone Joint Surg Am* 93 Suppl 2:76-83.
- Chandler DR, Glousman R, Hull D, McGuire PJ, Kim IS, Clarke IC, Sarmiento A. (1982) Prosthetic hip range of motion and impingement. The effects of head and neck geometry. *Clin Orthop Relat Res.* 166:284-91.
- Chang EY, McAnally JL, Van Horne JR, Statum S, Wolfson T, Gamst A, Chung CB. (2012) Metal-on-metal total hip arthroplasty: do symptoms correlate with MR imaging findings? *Radiology* 265:848-57.
- Chiu KY, Ng TP, Tang WM, Poon KC, Ho WY, Yip D. (2001) Charnley total hip arthroplasty in Chinese patients less than 40 years old. *J Arthroplasty.* 16:92-101.
- Charnley J. (1961) Arthroplasty of the hip. A new operation. *Lancet.* 1(7187):1129-32.
- Charnley J. Total hip replacement by low-friction arthroplasty. (1970) *Clin Orthop Relat Res* 72:7-21.
- Clarke IC, Donaldson T, Bowsher JG, Nasser S, Takahashi T. (2005) Current concepts of metal-on-metal hip resurfacing. *Orthop Clin North Am* 36:143,62, viii.
- Clarke IC, Good V, Williams P. (2000) Ultra-low wear rates for rigid-on-rigid bearings in total hip replacements. *Proc Inst Mech Eng H* 214:331-47.
- Coleman RF, Herrington J, Scales JT. (1973) Concentration of wear products in hair, blood, and urine after total hip replacement. *Br Med J* 1:527-9.
- Cooper HJ, Urban RM, Wixson RL, Meneghini RM, Jacobs JJ. (2013) Adverse local tissue reaction arising from corrosion at the femoral neck-body junction in a dual-taper stem with a cobalt-chromium modular neck. *J Bone Joint Surg Am* 95:865-72.
- Cordingley R, Kohan L, Ben-Nissan B. (2010) What happens to femoral neck bone mineral density after hip resurfacing surgery? *J Bone Joint Surg Br.* 92:1648-53.
- Cotella L, Raiton GT, Nunn D, Freeman MA, Revell PA. (1990) ICLH double-cup arthroplasty, 1980-1987. *J Arthroplasty* 5:349-57.
- Coulter G, Young DA, Dalziel RE, Shimmin AJ. (2012) Birmingham hip resurfacing at a mean of ten years: results from an independent centre. *J Bone Joint Surg Br* 94:315-21.
- Daniel J, Pynsent PB, McMinn DJ. (2004) Metal-on-metal resurfacing of the hip in patients under the age of 55 years with osteoarthritis. *J Bone Joint Surg Br* 86:177-84.
- Daniel J, Ziaee H, Pradhan C, McMinn DJ. (2009) Six-year results of a prospective study of metal ion levels in young patients with metal-on-metal hip resurfacings. *J Bone Joint Surg Br* 91:176-9.

- Daniel J, Ziaee H, Kamali A, Pradhan C, Band T, McMinn DJ. (2010) Ten-year results of a double-heat-treated metal-on-metal hip resurfacing. *J Bone Joint Surg Br.* 92:20-7.
- Davies AP, Willert HG, Campbell PA, Learmonth ID, Case CP. (2005) An unusual lymphocytic perivascular infiltration in tissues around contemporary metal-on-metal joint replacements. *J Bone Joint Surg Am* 87:18-27.
- Dawson J, Fitzpatrick R, Carr A, Murray D. (1996) Questionnaire on the perceptions of patients about total hip replacement. *J Bone Joint Surg Br* 78:185–190
- Debeyre J, Goutallier D. (1970) Urist hip socket and Moore prosthesis without cement for hip replacement. *Clin Orthop Relat Res.* 72:169-73.
- De Haan R, Pattyn C, Gill HS, Murray DW, Campbell PA, De Smet K. (2008) Correlation between inclination of the acetabular component and metal ion levels in metal-on-metal hip resurfacing replacement. *J Bone Joint Surg Br* 90:1291-7.
- DeLee JG, Charnley J. (1976) Radiological demarcation of cemented sockets in total hip replacement. *Clin Orthop Relat Res.* 121:20-32.
- Derbyshire B. (2008) Correction of acetabular cup orientation measurements for X-ray beam offset. *Med Eng Phys* 30:1119-26.
- De Smet K, De Haan R, Calistri A. (2008) Metal ion measurement as a diagnostic tool to identify problems with metal-on-metal hip resurfacing. *J Bone Joint Surg Am* 90 Suppl 4:202-8.
- Desloges W, Catelas I, Nishiwaki T, Kim PR, Beaulé PE. (2012) Do revised hip resurfacing arthroplasties lead to outcomes comparable to those of primary and revised total hip arthroplasties?. *Clin Orthop Relat Res* 470:3134-41.
- deSouza RM, Parsons NR, Oni T, Dalton P, Costa M, Krikler S. (2010) Metal ion levels following resurfacing arthroplasty of the hip: serial results over a ten-year period. *J Bone Joint Surg Br* 92:1642-7.
- Desy NM, Bergeron SG, Petit A, Huk OL, Antoniou J. (2010) Surgical Variables Influence Metal Ion Levels After Hip Resurfacing. *Clin Orthop Relat Res* 469:1635-41.
- D'Lima DD, Urquhart AG, Buehler KO, Walker RH, Colwell CW, Jr. (2000) The effect of the orientation of the acetabular and femoral components on the range of motion of the hip at different head-neck ratios. *J Bone Joint Surg Am* 82:315-21.
- Duff-Barclay I, Scales JT, Wilson JN. (1966) Biomechanics. The development of the Stanmore total hip replacement. *Proc R Soc Med.* 59:948-51.
- Duffy GP, Berry DJ, Rowland C, Cabanela ME. (2001) Primary uncemented total hip arthroplasty in patients <40 years old: 10- to 14-year results using first-generation proximally porous-coated implants. *J Arthroplasty. Suppl* 1:140-4.
- Dunstan E, Ladon D, Whittingham-Jones P, Carrington R, Briggs TW. (2008) Chromosomal aberrations in the peripheral blood of patients with metal-on-metal hip bearings. *J Bone Joint Surg Am* 90:517-22.
- Evans EM, Freeman MA, Miller AJ, Vernon-Roberts B. (1974) Metal sensitivity as a cause of bone necrosis and loosening of the prosthesis in total joint replacement. *J Bone Joint Surg Br* 56:626-42.
- Eddine TA, Migaud H, Chantelot C, Cotten A, Fontaine C, Duquenois A. (2001) Variations of pelvic anteversion in the lying and standing positions: analysis of 24 control subjects and implications for CT measurement of position of a prosthetic cup. *Surg Radiol Anat* 23:105-10.
- Eskelinen A, Remes V, Helenius I, Pulkkinen P, Nevalainen J, Paavolainen P. (2005) Total hip arthroplasty for primary osteoarthritis in younger patients in the Finnish

- arthroplasty register. 4,661 primary replacements followed for 0-22 years. *Acta Orthop* 76:28-41.
- Fabeck L, Farrokh D, Tolley M, Descamps PY, Gebhart M, Delince P. (1999) A method to measure acetabular cup anteversion after total hip replacement. *Acta Orthop Belg* 65:485-91.
- Freeman MA. (1978) Total surface replacement hip arthroplasty. *Clin Orthop Relat Res* 134:2-4.
- Freeman MA, Cameron HU, Brown GC. (1978) Cemented double cup arthroplasty of the hip: a 5 year experience with the ICLH prosthesis. *Clin Orthop Relat Res* 134:45-52.
- Freeman MA, Bradley GW. (1983) ICLH surface replacement of the hip. An analysis of the first 10 years. *J Bone Joint Surg Br* 65:405-11.
- Furnes O, Lie SA, Espehaug B, Vollset SE, Engesaeter LB, Havelin LI. (2001) Hip disease and the prognosis of total hip replacements. A review of 53,698 primary total hip replacements reported to the Norwegian Arthroplasty Register 1987-99. *J Bone Joint Surg Br* 83:579-86.
- Furuya K, Tsuchiya M, Kawachi S. (1978) Socket-cup arthroplasty. *Clin Orthop Relat Res* 134:41-4.
- Garbuz DS, Tanzer M, Greidanus NV, Masri BA, Duncan CP. (2010) The John Charnley Award: Metal-on-metal hip resurfacing versus large-diameter head metal-on-metal total hip arthroplasty: a randomized clinical trial. *Clin Orthop Relat Res* 468:318-25.
- Garcia-Rey E, Cruz-Pardos A, Garcia-Cimbrelo E. (2009) Alumina-on-alumina total hip arthroplasty in young patients: diagnosis is more important than age. *Clin Orthop Relat Res* 467:2281-9.
- Garrett SJ, Bolland BJ, Yates PJ, Gardner EM, Latham JM. (2011) Femoral revision in hip resurfacing compared with large-bearing metal-on-metal hip arthroplasty. *J Arthroplasty* 26:1214-8.
- Gerard Y. (1978) Hip arthroplasty by matching cups. *Clin Orthop Relat Res* 134:25-35.
- Ghelman B, Kepler CK, Lyman S, Della Valle AG. (2009) CT outperforms radiography for determination of acetabular cup version after THA. *Clin Orthop Relat Res* 467:2362-70.
- Ghomrawi HM, Dolan MM, Rutledge J, Alexiades MM. (2011) Recovery expectations of hip resurfacing compared to total hip arthroplasty: a matched pairs study. *Arthritis Care Res* 63:1753-7.
- Girard J, Lavigne M, Vendittoli PA, Roy AG. (2006) Biomechanical reconstruction of the hip: a randomised study comparing total hip resurfacing and total hip arthroplasty. *J Bone Joint Surg Br* 88:721-6.
- Girard J, Bocquet D, Autissier G, Fouilleron N, Fron D, Migaud H. (2010) Metal-on-metal hip arthroplasty in patients thirty years of age or younger. *J Bone Joint Surg Am* 92:2419-26.
- Glyn-Jones S, Pandit H, Kwon YM, Doll H, Gill HS, Murray DW. (2009) Risk factors for inflammatory pseudotumour formation following hip resurfacing. *J Bone Joint Surg Br* 91:1566-74.
- Gomez PF, Morcuende JA. (2005) Early Attempts at Hip Arthroplasty: 1700s to 1950s. *Iowa Orthop J* 25:25-9.
- Grammatopolous G, Pandit H, Kwon YM. (2009) Hip resurfacings revised for inflammatory pseudotumour have a poor outcome. *J Bone Joint Surg Br* 91:1019-24.

- Grammatopoulos G, Pandit H, Glyn-Jones S. (2010a) Optimal acetabular orientation for hip resurfacing. *J Bone Joint Surg Br* 2010;92:1072-8.
- Grammatopoulos G, Pandit H, Murray DW, Gill HS. (2010b) The relationship between head-neck ratio and pseudotumour formation in metal-on-metal resurfacing arthroplasty of the hip. *J Bone Joint Surg Br.* 92:1527-34.
- Grammatopoulos G, Pandit H, Kamali A. (2013) The correlation of wear with histological features after failed hip resurfacing arthroplasty. *J Bone Joint Surg Am* 95:e81.
- Griffin WL, Nanson CJ, Springer BD, Davies MA, Fehring TK. (2010) Reduced articular surface of one-piece cups: a cause of runaway wear and early failure. *Clin Orthop Relat Res* 468:2328-32.
- Grigoris P, Roberts P, Panousis K, Jin Z. (2006) Hip resurfacing arthroplasty: the evolution of contemporary designs. *Proc Inst Mech Eng H* 220:95-105.
- Gross TP, Liu F. (2008) Metal-on-metal hip resurfacing with an uncemented femoral component. A seven-year follow-up study. *J Bone Joint Surg Am* 90; Suppl 3:32-7.
- Gross TP, Liu F. (2012a) Hip resurfacing with the Biomet Hybrid ReCap-Magnum system: 7-year results. *J Arthroplasty.* 27:1683-1689.
- Gross TP, Liu F, Webb LA. (2012b) Clinical outcome of the metal-on-metal hybrid Corin Cormet 2000 hip resurfacing system: an up to 11-year follow-up study. *J Arthroplasty* 27(4):533-538.
- Gross TP, Liu F. (2012c) Comparative study between patients with osteonecrosis and osteoarthritis after hip resurfacing arthroplasty. *Acta Orthop Belg.* 78:735-44.
- Gruber FW, Bock A, Trattnig S, Lintner F, Ritschl P. (2007) Cystic lesion of the groin due to metallosis: a rare long-term complication of metal-on-metal total hip arthroplasty. *J Arthroplasty* 22:923-7.
- Haenle M, Heitner A, Mittelmeier W, Barbano R, Scholz R, Steinhäuser E, Bader R. (2007) Assessment of cup position from plain radiographs: impact of pelvic tilting. *Surg Radiol Anat* 29:29-35.
- Hallab N, Merritt K, Jacobs JJ. (2001) Metal sensitivity in patients with orthopaedic implants. *J Bone Joint Surg Am* 83:428-36.
- Hannemann F, Hartmann A, Schmitt J. (2013) European multidisciplinary consensus statement on the use and monitoring of metal-on-metal bearings for total hip replacement and hip resurfacing. *Orthop Traumatol Surg Res* 99:263-71.
- Harris WH. (1969) Traumatic arthritis of the hip after dislocation and acetabular fractures: treatment by mold arthroplasty. An end-result study using a new method of result evaluation. *J Bone Joint Surg AM* 51:737-755.
- Hart AJ, Sabah S, Henckel J. (2009) The painful metal-on-metal hip resurfacing. *J Bone Joint Surg Br* 91:738-44.
- Hart AJ, Ilo K, Underwood R, ym. (2011a) The relationship between the angle of version and rate of wear of retrieved metal-on-metal resurfacings: a prospective, CT-based study. *J Bone Joint Surg Br* 93:315-20.
- Hart AJ, Sabah SA, Bandi AS, ym. (2011b) Sensitivity and specificity of blood cobalt and chromium metal ions for predicting failure of metal-on-metal hip replacement. *J Bone Joint Surg Br* 93:1308-13.
- Hart AJ, Skinner JA, Henckel J, Sampson B, Gordon F. (2011c) Insufficient acetabular version increases blood metal ion levels after metal-on-metal hip resurfacing. *Clin Orthop Relat Res* 469:2590-7.
- Hart AJ, Satchithananda K, Liddle A. (2012) Pseudotumors in association with well-functioning metal-on-metal hip prostheses: a case-control study using three-

- dimensional computed tomography and magnetic resonance imaging. *J Bone Joint Surg Am* 94:317-25.
- Hartmann A, Hannemann F, Lutzner J. (2013) Metal Ion Concentrations in Body Fluids after Implantation of Hip Replacements with Metal-on-Metal Bearing - Systematic Review of Clinical and Epidemiological Studies. *PLoS One* 8:e70359.
- Hassan DM, Johnston GH, Dust WN, Watson LG, Cassidy D. (1995) Radiographic calculation of anteversion in acetabular prostheses. *J Arthroplasty* 10:369-72.
- Hauptfleisch J, Pandit H, Grammatopoulos G, Gill HS, Murray DW, Ostlere S. (2012) A MRI classification of periprosthetic soft tissue masses (pseudotumours) associated with metal-on-metal resurfacing hip arthroplasty. *Skeletal Radiol* 41:149-55.
- Hayashi Y, Miki H, Nishii T, Hananouchi T, Yoshikawa H, Sugano N. (2007) Proximal femoral bone mineral density after resurfacing total hip arthroplasty and after standard stem-type cementless total hip arthroplasty, both having similar neck preservation and the same articulation type. *J Arthroplasty*. 22:1208-13.
- Hays RD, Sherbourne CD, Mazel RM. (1993) The RAND 36-item health survey 1.0. *Health Econ*. 15(3):217-27.
- Hayter CL, Gold SL, Koff MF. (2012) MRI findings in painful metal-on-metal hip arthroplasty. *AJR Am J Roentgenol* 199:884-93.
- Heilpern GN, Shah NN, Fordyce MJ. (2008) Birmingham hip resurfacing arthroplasty: a series of 110 consecutive hips with a minimum five-year clinical and radiological follow-up. *J Bone Joint Surg Br* 90:1137-42.
- Heisel C, Silva M, Skipor AK, Jacobs JJ, Schmalzried TP. (2005) The relationship between activity and ions in patients with metal-on-metal bearing hip prostheses. *J Bone Joint Surg Am* 87:781-7.
- Herman KA, Highcock AJ, Moorehead JD, Scott SJ. (2011) A comparison of leg length and femoral offset discrepancies in hip resurfacing, large head metal-on-metal and conventional total hip replacement: a case series. *J Orthop Surg Res* 6:65-71.
- Hing CB, Back DL, Bailey M, Young DA, Dalziel RE, Shimmin AJ. (2007) The results of primary Birmingham hip resurfacings at a mean of five years. An independent prospective review of the first 230 hips. *J Bone Joint Surg Br* 89:1431-8.
- Holland JP, Langton DJ, Hashmi M. (2012) Ten-year clinical, radiological and metal ion analysis of the Birmingham Hip Resurfacing: from a single, non-designer surgeon. *J Bone Joint Surg Br* 94:471-6.
- Howie DW, Campbell D, McGee M, Cornish BL. (1990) Wagner resurfacing hip arthroplasty. The results of one hundred consecutive arthroplasties after eight to ten years. *J Bone Joint Surg Am* 72:708-14.
- Howie DW, McGee MA, Costi K, Graves SE. (2006) Metal-on-metal resurfacing versus total hip replacement-the value of a randomized clinical trial. *Orthop Clin North Am* 36:195-201.
- Huber M, Reinisch G, Zenz P, Zweymuller K, Lintner F. (2010) Postmortem study of femoral osteolysis associated with metal-on-metal articulation in total hip replacement: an analysis of nine cases. *J Bone Joint Surg Am* 92:1720-31.
- Incavo SJ, Thompson MT, Gold JE, Patel RV, Icenogle KD, Noble PC. (2011) Which procedure better restores intact hip range of motion: total hip arthroplasty or resurfacing? A combined cadaveric and computer simulation study. *J Arthroplasty*. 26:391-7

- Jack CM, Walter WL, Shimmin AJ, Cashman K, de Steiger RN. Large diameter metal on metal articulations. (2013) Comparison of total hip arthroplasty and hip resurfacing arthroplasty. *J Arthroplasty* 28:650-3.
- Jameson SS, Langton DJ, Nargol AV. (2010) Articular surface replacement of the hip: a prospective single-surgeon series. *J Bone Joint Surg Br.* 92:28-37
- Jeffers JR, Roques A, Taylor A, Tuke MA. (2009) The problem with large diameter metal-on-metal acetabular cup inclination. *Bull NYU Hosp Jt Dis* 67:189-92.
- Kalteis T, Handel M, Herold T, Perlick L, Paetzel C, Grifka J. (2006) Position of the acetabular cup -- accuracy of radiographic calculation compared to CT-based measurement. *Eur J Radiol* 58:294-300.
- Khan M, Kuiper JH, Edwards D, Robinson E, Richardson JB. (2009) Birmingham hip arthroplasty: five to eight years of prospective multicenter results. *J Arthroplasty* 24:1044-50.
- Khan M, Kuiper JH, Richardson JB. (2008) The exercise-related rise in plasma cobalt levels after metal-on-metal hip resurfacing arthroplasty. *J Bone Joint Surg Br* 90:1152-7.
- Kinkel S, Wollmerstedt N, Kleinhans JA, Hendrich C, Heisel C. (2009) Patient activity after total hip arthroplasty declines with advancing age. *Clin Orthop Relat Res* 467:2053-8.
- Kishida Y, Sugano N, Nishii T, Miki H, Yamaguchi K, Yoshikawa H. (2004) Preservation of the bone mineral density of the femur after surface replacement of the hip. *J Bone Joint Surg Br.* 86:185-9.
- Kluess D, Zietz C, Lindner T, Mittelmeier W, Schmitz KP, Bader R. (2008) Limited range of motion of hip resurfacing arthroplasty due to unfavorable ratio of prosthetic head size and femoral neck diameter. *Acta Orthop* 79:748-54.
- Korovessis P, Petsinis G, Repanti M, Repantis T. (2006) Metallosis after contemporary metal-on-metal total hip arthroplasty. Five to nine-year follow-up. *J Bone Joint Surg Am* 88:1183-91.
- Krantz N, Miletic B, Migaud H, Girard J. (2012) Hip resurfacing in patients under thirty years old: an attractive option for young and active patients. *Int Orthop* 36:1789-94.
- Kwon YM, Glyn-Jones S, Simpson DJ. (2010) Analysis of wear of retrieved metal-on-metal hip resurfacing implants revised due to pseudotumours. *J Bone Joint Surg Br* 92:356-61.
- Kwon YM, Ostlere SJ, McLardy-Smith P, Athanasou NA, Gill HS, Murray DW. (2011) "Asymptomatic" pseudotumors after metal-on-metal hip resurfacing arthroplasty: prevalence and metal ion study. *J Arthroplasty* 26:511-8.
- Lalmohamed A, MacGregor AJ, de Vries F, Leufkens HG, van Staa TP. (2013) Patterns of risk of cancer in patients with metal-on-metal hip replacements versus other bearing surface types: a record linkage study between a prospective joint registry and general practice electronic health records in England. *PLoS One* 8:e65891.
- Langton DJ, Sprowson AP, Joyce TJ, ym. (2009) Blood metal ion concentrations after hip resurfacing arthroplasty: a comparative study of articular surface replacement and Birmingham Hip Resurfacing arthroplasties. *J Bone Joint Surg Br* 2009;91:1287-95.
- Langton DJ, Jameson SS, Joyce TJ, Hallab NJ, Natu S, Nargol AV. (2010a) Early failure of metal-on-metal bearings in hip resurfacing and large-diameter total hip replacement: A consequence of excess wear. *J Bone Joint Surg Br* 92:38-46.
- Langton DJ, Sprowson AP, Mahadeva D, Bhatnagar S, Holland JP, Nargol AV. (2010b) Cup anteversion in hip resurfacing: validation of EBRA and the presentation of a simple clinical grading system. *J Arthroplasty* 25:607-13.

- Langton DJ, Joyce TJ, Jameson SS, ym. (2011a) Adverse reaction to metal debris following hip resurfacing: THE INFLUENCE OF COMPONENT TYPE, ORIENTATION AND VOLUMETRIC WEAR. *J Bone Joint Surg Br* 2011;93:164-71.
- Langton DJ, Jameson SS, Joyce TJ, ym. (2011b) Accelerating failure rate of the ASR total hip replacement. *J Bone Joint Surg Br* 93:1011-6.
- Lavigne M, Therrien M, Nantel J, Roy A, Prince F, Vendittoli PA. (2010) The John Charnley Award: The functional outcome of hip resurfacing and large-head THA is the same: a randomized, double-blind study. *Clin Orthop Relat Res* 468:326-36.
- Lavigne M, Belzile EL, Roy A, Morin F, Amzica T, Vendittoli PA. (2011a) Comparison of whole-blood metal ion levels in four types of metal-on-metal large-diameter femoral head total hip arthroplasty: the potential influence of the adapter sleeve. *J Bone Joint Surg Am*. 93 Suppl 2:128-36.
- Lavigne M, Ganapathi M, Mottard S, Girard J, Vendittoli PA. (2011b) Range of motion of large head total hip arthroplasty is greater than 28 mm total hip arthroplasty or hip resurfacing. *Clin Biomech* 26:267:273.
- Lazarinis S, Kärrholm J, Hailer NP. (2010) Increased risk of revision of acetabular cups coated with hydroxyapatite. *Acta Orthop*. 81:53-9.
- Le Duff MJ, Wisk LE, Amstutz HC. (2009) Range of motion after stemmed total hip arthroplasty and hip resurfacing - a clinical study. *Bull NYU Hosp Jt Dis*. 67:177-81
- Le Duff MJ, Amstutz HC. (2012) The relationship of sporting activity and implant survivorship after hip resurfacing. *J Bone Joint Surg Am* 94:911-8.
- Leclercq S, Lavigne M, Girard J, Chiron P, Vendittoli PA. (2013) Durom hip resurfacing system: retrospective study of 644 cases with an average follow-up of 34 months. *Orthop Traumatol Surg Res*. 99:273-9
- Lewinnek GE, Lewis JL, Tarr R, Compere CL, Zimmerman JR. (1978) Dislocations after total hip-replacement arthroplasties. *J Bone Joint Surg Am* 60:217-20.
- Li J, He C, Li D, Zheng W, Liu D, Xu W. (2013) Early failure of the durom prosthesis in metal-on-metal hip resurfacing in Chinese patients. *J Arthroplasty*. 28:1816-21
- Liddle AD, Satchithananda K, Henckel J. (2013) Revision of metal-on-metal hip arthroplasty in a tertiary center: a prospective study of 39 hips with between 1 and 4 years of follow-up. *Acta Orthop* 84:237-45.
- Lingard EA, Muthumayandi K, Holland JP. (2009) Comparison of patient-reported outcomes between hip resurfacing and total hip replacement. *J Bone Joint Surg Br* 91:1550-4.
- Lohmann CH, Meyer H, Nuechtern JV. (2013) Periprosthetic Tissue Metal Content but Not Serum Metal Content Predicts the Type of Tissue Response in Failed Small-Diameter Metal-on-Metal Total Hip Arthroplasties. *J Bone Joint Surg Am* 95:1561-8.
- Long WT, Dastane M, Harris MJ, Wan Z, Dorr LD. (2010) Failure of the Durom Metasul acetabular component. *Clin Orthop Relat Res*. 468:400-5
- Loughead JM, Chesney D, Holland JP, McCaskie AW. (2005) Comparison of offset in Birmingham hip resurfacing and hybrid total hip arthroplasty. *J Bone Joint Surg Br* 87:163-6.
- Lübbecke A, Garavaglia G, Barea C, Stern R, Peter R, Hoffmeyer P. (2011) Influence of patient activity on femoral osteolysis at five and ten years following hybrid total hip replacement. *J Bone Joint Surg Br*. 93:456-63
- Lunceford EM Jr. (1970) Total hip replacement using McBride cup and the Moore prosthesis. *Clin Orthop Relat Res*. 72:201-4.

- MacKenzie JR, O'Connor GJ. (2012) Functional outcomes for 2 years comparing hip resurfacing and total hip arthroplasty. *J Arthroplasty* 27:750,7.e2.
- Macnair RD, Wynn-Jones H, Wimhurst JA, Toms A, Cahir J. (2013) Metal ion levels not sufficient as a screening measure for adverse reactions in metal-on-metal hip arthroplasties. *J Arthroplasty* 28:78-83.
- Madhu TS, Akula MR, Raman RN, Sharma HK, Johnson VG. (2011) The Birmingham hip resurfacing prosthesis: an independent single surgeon's experience at 7-year follow-up. *J Arthroplasty*. 26:1-8
- Mai MT, Schmalzried TP, Dorey FJ, Campbell PA, Amstutz HC. (1996) The contribution of frictional torque to loosening at the cement-bone interface in Tharies hip replacements. *J Bone Joint Surg Am* 78:505-11.
- Makela KT, Visuri T, Pulkkinen P. (2012) Risk of cancer with metal-on-metal hip replacements: population based study. *BMJ* 345:e4646.
- Mäkelä KT, Visuri T, Pulkkinen P, Eskelinen A, Remes V, Virolainen P, Junnila M, Pukkala E. (2014) Cancer incidence and cause-specific mortality in patients with metal-on-metal hip replacements in Finland. *Acta Orthop*. 85:32-8
- Malek IA, King A, Sharma H. (2012) The sensitivity, specificity and predictive values of raised plasma metal ion levels in the diagnosis of adverse reaction to metal debris in symptomatic patients with a metal-on-metal arthroplasty of the hip. *J Bone Joint Surg Br* 94:1045-50.
- Malik A, Maheshwari A, Dorr LD. (2007) Impingement with total hip replacement. *J Bone Joint Surg Am* 89:1832-42.
- Malviya A, Lingard EA, Malik A, Bowman R, Holland JP. (2010) Hip flexion after Birmingham hip resurfacing: role of cup anteversion, anterior femoral head-neck offset, and head-neck ratio. *J Arthroplasty* 25:387-91.
- Malviya A, Ng L, Hashmi M, Rawlings D, Holland JP. (2013) Patterns of changes in femoral bone mineral density up to five years after hip resurfacing. *J Arthroplasty*. 28:1025-30.
- Marx A, von Knoch M, Pfortner J, Wiese M, Saxler G. (2006) Misinterpretation of cup anteversion in total hip arthroplasty using planar radiography. *Arch Orthop Trauma Surg* 126:487-92.
- Mayr E, Kessler O, Prassl A, Rachbauer F, Krismer M, Nogler M. (2005) The frontal pelvic plane provides a valid reference system for implantation of the acetabular cup: spatial orientation of the pelvis in different positions. *Acta Orthop*. 76:848-53.
- Matthies A, Underwood R, Cann P. (2011) Retrieval analysis of 240 metal-on-metal hip components, comparing modular total hip replacement with hip resurfacing. *J Bone Joint Surg Br* 93:307-14.
- Matthies AK, Racasan R, Bills P, Blunt L, Cro S, Panagiotidou A, Blunn G, Skinner J, Hart AJ. (2013) Material loss at the taper junction of retrieved large head metal-on-metal total hip replacements. *J Orthop Res* 31:1677-85.
- Matthies AK, Skinner JA, Osmani H, Henckel J, Hart AJ. (2012) Pseudotumors are common in well-positioned low-wearing metal-on-metal hips. *Clin Orthop Relat Res* 470:1895-906.
- McBride TJ, Prakash D. (2011) How to read a postoperative total hip replacement radiograph. *Postgrad Med J* 87:101-9.
- McGrath MS, Desser DR, Ulrich SD, Seyler TM, Marker DR, Mont MA. (2008) Total hip resurfacing in patients who are sixty years of age or older. *J Bone Joint Surg Am*. 90 Suppl 3:27-31.

- McKee GK, Watson-Farrar J. (1966) Replacement of arthritic hips by the McKee-Farrar prosthesis. *J Bone Joint Surg Br.* 48:245-59.
- McKee GK. (1970) Development of total prosthetic replacement of the hip. *Clin Orthop Relat Res* 72:85-103.
- McKenzie AW, Aitken CV, Ridsdill-Smith R. (1967) Urticaria after insertion of Smith-Petersen Vitallium nail. *Br Med J.* 4:36.
- McKibbin B. Anatomical factors in the stability of the hip joint in the newborn. (1970) *J Bone Joint Surg Br* 52:148-59.
- McMinn D, Treacy R, Lin K, Pynsent P. (1996) Metal on metal surface replacement of the hip. Experience of the McMinn prosthesis. *Clin Orthop Relat Res* 329 Suppl:S89-98
- McMinn DJ, Daniel J, Ziaee H, Pradhan C. (2008) Results of the Birmingham Hip Resurfacing dysplasia component in severe acetabular insufficiency: a six- to 9.6-year follow-up. *J Bone Joint Surg Br.* 90:715-23.
- McMinn DJW (2009) *Modern Hip Resurfacing*. ISBN 978-1848000872. Springer, Medicines and Healthcare Products Regulation Agency. (2012) Medical Device Alert: All metal-on-metal (MoM) hip replacements (MDA/2012/036). <http://www.mhra.gov.uk/home/groups/dts-bs/documents/medicaldevicealert/con155767.pdf>.
- Medicines and Healthcare Products Regulation Agency. (2010) Medical Device Alert: ASR™ hip replacement implants manufactured by DePuy International Ltd (MDA/2010/069)2010. <http://www.mhra.gov.uk/home/groups/dtsbs/documents/medicaldevicealert/con093791.pdf>.
- Mont MA, Seyler TM, Ulrich SD, Beaulé PE, Boyd HS, Grecula MJ, Goldberg VM, Kennedy WR, Marker DR, Schmalzried TP, Sparling EA, Vail TP, Amstutz HC. (2007) Effect of changing indications and techniques on total hip resurfacing. *Clin Orthop Relat Res.* 465:63-70.
- Mont MA, Marker DR, Smith JM, Ulrich SD, McGrath MS. (2009) Resurfacing is comparable to total hip arthroplasty at short-term follow-up. *Clin Orthop Relat Res* 467:66-71.
- Murray DW. (1993) The definition and measurement of acetabular orientation. *J Bone J Surg Br* 75:228-32.
- Murray DW, Grammatopoulos G, Pandit H, Gundle R, Gill HS, McLardy-Smith P. (2012) The ten-year survival of the Birmingham hip resurfacing: an independent series. *J Bone Joint Surg Br* 94:1180-6.
- Naal FD, Pilz R, Munzinger U, Hersche O, Leunig M. (2011) High revision rate at 5 years after hip resurfacing with the Durom implant. *Clin Orthop Relat Res.* 469:2598-604
- National Joint Registry for England and Wales. 10th Annual Report 2013. http://www.njrcentre.org.uk/njrcentre/Portals/0/Documents/England/Reports/10th_annual_report/NJR%2010th%20Annual%20Report%202013%20B.pdf.
- Natu S, Sidaginamale RP, Gandhi J, Langton DJ, Nargol AV. (2012) Adverse reactions to metal debris: histopathological features of periprosthetic soft tissue reactions seen in association with failed metal on metal hip arthroplasties. *J Clin Pathol* 65:409-18.
- Nesse E. (1991) THARIES (Total Hip Articular Replacement by Internal Eccentric Shells) double cup prosthesis. A 10-year follow-up study. *Tidsskr Nor Laegeforen* 111:1953-5.

- Nishii T, Sakai T, Takao M, Yoshikawa H, Sugano N. (2012) Ultrasound screening of periarticular soft tissue abnormality around metal-on-metal bearings. *J Arthroplasty* 27:895-900.
- Nishio A, Eguchi M, Kaibara N. (1978) Socket and cup surface replacement of the hip. *Clin Orthop Relat Res.* 134:53-8.
- Nizard R, Pourreyron D, Raouf A, Hannouche D, Sedel L. (2008) Alumina-on-alumina hip arthroplasty in patients younger than 30 years old. *Clin Orthop Relat Res* 466:317-23.
- Olivecrona H, Weidenhielm L, Olivecrona L, Beckman MO, Stark A, Noz ME, Maguire GQ Jr, Zeleznik MP, Svensson L, Jonson T. (2004) A new CT method for measuring cup orientation after total hip arthroplasty: a study of 10 patients. *Acta Orthop Scand* 75:252-60.
- Ollivere B, Darrach C, Barker T, Nolan J, Porteous MJ. (2009) Early clinical failure of the Birmingham metal-on-metal hip resurfacing is associated with metallosis and soft-tissue necrosis. *J Bone Joint Surg Br* 91:1025-30.
- Park YS, Moon YW, Lim SJ, Yang JM, Ahn G, Choi YL. (2005) Early osteolysis following second-generation metal-on-metal hip replacement. *J Bone Joint Surg Am* 87:1515-21.
- Paulsen A, Odgaard A, Overgaard S. (2012) Translation, cross-cultural adaptation and validation of the Danish version of the Oxford hip score: Assessed against generic and disease-specific questionnaires. *Bone Joint Res* 1:225-33.
- Penny JO, Brixen K, Varmarken JE, Ovesen O, Overgaard S. (2012) Changes in bone mineral density of the acetabulum, femoral neck and femoral shaft, after hip resurfacing and total hip replacement: two-year results from a randomised study. *J Bone Joint Surg Br.* 94:1036-44.
- Pollard TC, Baker RP, Eastaugh-Waring SJ, Bannister GC. (2006) Treatment of the young active patient with osteoarthritis of the hip. A five- to seven-year comparison of hybrid total hip arthroplasty and metal-on-metal resurfacing. *J Bone Joint Surg Br* 88:592-600.
- Pradhan R. (1999) Planar anteversion of the acetabular cup as determined from plain anteroposterior radiographs. *J Bone Joint Surg Br* 81:431-5.
- Pritchett JW (2008) Curved-stem Hip Resurfacing: Minimum 20-year Followup. *Clin Orthop Relat Res.* May 466: 1177–1185.
- Rahman L, Muirhead-Allwood SK, Alkinj M. (2010) What is the midterm survivorship and function after hip resurfacing? *Clin Orthop Relat Res.* 468:3221-7
- Ring PA. (1970) Total replacement of the hip. *Clin Orthop Relat Res* 72:161-8.
- Rokkum M, Reigstad A, Johansson CB. (2002) HA particles can be released from well-fixed HA-coated stems: histopathology of biopsies from 20 hips 2-8 years after implantation. *Acta Orthop Scand.* 73:298-306.
- Sabah SA, Mitchell AW, Henckel J, Sandison A, Skinner, Hart AJ. (2011) Magnetic resonance imaging findings in painful metal-on-metal hips: a prospective study. *J Arthroplasty* 26:71-76.
- Salzer M, Knahr K, Locke H, Stark N. (1978) Cement-free bioceramic double-cup endoprosthesis of the hip-joint. *Clin Orthop Relat Res* 134:80-6.
- Santavirta S, Bohler M, Harris WH. (2003) Alternative materials to improve total hip replacement tribology. *Acta Orthop Scand* 74:380-8.

- Sariali E, Lazennec JY, Khiami F, Catonne Y. (2009) Mathematical evaluation of jumping distance in total hip arthroplasty: influence of abduction angle, femoral head offset, and head diameter. *Acta Orthop* 80:277-82.
- Sayed SA, Johnson AJ, Stroh DA, Gross TP, Mont MA. (2010) Hip Resurfacing in Patients Who Have Osteonecrosis and are 25 Years or Under. *Clin Orthop Relat Res* 469:1582-8.
- Schmalzried TP, Fowble VA, Ure KJ, Amstutz HC. (1996) Metal on metal surface replacement of the hip. Technique, fixation, and early results. *Clin Orthop Relat Res*. 329 Suppl:S106-14
- Schmalzried TP, Shepherd EF, Dorey FJ, Jackson WO, dela Rosa M, Fa'vae F, McKellop HA, McClung CD, Martell J, Moreland JR, Amstutz HC. (2000) The John Charnley Award. Wear is a function of use, not time. *Clin Orthop Relat Res*. 381:36-46.
- Sechriest VF, 2nd, Kyle RF, Marek DJ, Spates JD, Saleh KJ, Kuskowski M. (2007) Activity level in young patients with primary total hip arthroplasty: a 5-year minimum follow-up. *J Arthroplasty* 22:39-47.
- Seradge H, Nagle KR, Miller RJ. (1982) Analysis of version in the acetabular cup. *Clin Orthop Relat Res* 166:152-7.
- Seyler TM, Marker DR, Boyd HS, Zywiell MG, McGrath MS, Mont MA. (2009) Preoperative evaluation to determine candidates for metal-on-metal hip resurfacing. *J Bone Joint Surg Am* 91 Suppl 6:32-41.
- Siebel T, Maubach S, Morlock MM. (2006) Lessons learned from early clinical experience and results of 300 ASR hip resurfacing implantations. *Proc Inst Mech Eng H*. 220:345-53.
- Simon JP, Berger P, Bellemans J. (2011) Total hip arthroplasty in patients less than 40 years old with avascular necrosis of the femoral head. A 5 to 19-year follow-up study. *Acta Orthop Belg* 77:53-60.
- Sivash KM. (1969) The development of a total metal prosthesis for the hip joint from a partial joint replacement. *Reconstr Surg Traumatol*. 11:53-62.
- Smith-Petersen MN. (1948) Evolution of mould arthroplasty of the hip joint. *J Bone Joint Surg Br* 30:59-75.
- Smolders JM, Pakvis DF, Hendrickx BW, Verdonschot N, van Susante JL. (2013) Periacetabular bone mineral density changes after resurfacing hip arthroplasty versus conventional total hip arthroplasty. A randomized controlled DEXA study. *J Arthroplasty*. 28:1177-84
- Steffen RT, Pandit HP, Palan J, Beard DJ, Gundle R, McLardy-Smith P, Murray DW. (2008) Gill HS. The five-year results of the Birmingham Hip Resurfacing arthroplasty: an independent series. *J Bone Joint Surg Br*. 90:436-41.
- Steffen RT, Foguet PR, Krikler SJ, Gundle R, Beard DJ, Murray DW. (2009) Femoral neck fractures after hip resurfacing. *J Arthroplasty*. 24:614-9.
- Stulberg BN, Trier KK, Naughton M, Zadzilka JD. (2008) Results and lessons learned from a United States hip resurfacing investigational device exemption trial. *J Bone Joint Surg Am*. 90 Suppl 3:21-6.
- Sweetnam R. (1974) Editorial: Metal sensitivity. *J Bone Joint Surg Br* 56:601-2.
- Tanaka S. (1978) Surface replacement of the hip joint. *Clin Orthop Relat Res*. 134:75-9.
- Tannast M, Murphy SB, Langlotz F, Anderson SE, Siebenrock KA. (2006) Estimation of pelvic tilt on anteroposterior X-rays--a comparison of six parameters. *Skeletal Radiol* 235:149-55.

- Tapaninen T, Kröger H, Jurvelin J, Venesmaa P. (2012) Femoral neck bone mineral density after resurfacing hip arthroplasty. *Scand J Surg.* 101:211-5.
- Toms AP, Marshall TJ, Cahir J. (2008) MRI of early symptomatic metal-on-metal total hip arthroplasty: a retrospective review of radiological findings in 20 hips. *Clin Radiol* 63:49-58.
- Treacy RB, McBryde CW, Pynsent PB. (2005) Birmingham hip resurfacing arthroplasty. A minimum follow-up of five years. *J Bone Joint Surg Br* 87:167-70.
- Treacy RB, McBryde CW, Shears E, Pynsent PB. (2011) Birmingham hip resurfacing: a minimum follow-up of ten years. *J Bone Joint Surg Br* 93:27-33.
- Trentani C, Vaccarino F. (1978) The Paltrinieri-Trentani hip joint resurface arthroplasty. *Clin Orthop Relat Res.* 134:36-40.
- U.S. Food and Drug Administration. (2013) Metal-on-Metal Hip Implants. <http://www.fda.gov/MedicalDevices/ProductsandMedicalProcedures/ImplantsandProsthetics/MetalonMetalHipImplants/>.
- Underwood R, Matthies A, Cann P, Skinner, Hart AJ. (2011) A comparison of explanted Articular Surface Replacement and Birmingham Hip Resurfacing components. *J Bone Joint Surg Br* 93:1169-77.
- Vail TP, Mina CA, Yergler JD, Pietrobon R. (2006) Metal-on-metal hip resurfacing compares favorably with THA at 2 years followup. *Clin Orthop Relat Res.* 453:123-31
- Van Der Straeten C, Grammatopoulos G, Gill HS, Calistri A, Campbell P, De Smet KA. (2012) The 2012 Otto Aufranc Award: The Interpretation of Metal Ion Levels in Unilateral and Bilateral Hip Resurfacing. *Clin Orthop Relat Res* 471:377-85..
- Vendittoli PA, Ganapathi M, Nuño N, Plamondon D, Lavigne M. (2007) Factors affecting hip range of motion in surface replacement arthroplasty. *Clin Biomech.* 2007 22:1004-12.
- Venesmaa PK, Kröger HP, Jurvelin JS, Miettinen HJ, Suomalainen OT, Alhava EM. (2003) Periprosthetic bone loss after cemented total hip arthroplasty: a prospective 5-year dual energy radiographic absorptiometry study of 15 patients. *Acta Orthop Scand.* 74:31-6.
- Visser JD, Konings JG. (1981) A new method for measuring angles after total hip arthroplasty. A study of the acetabular cup and femoral component. *J Bone Joint Surg Br* 63:556-9.
- Visuri T, Pukkala E, Paavolainen P, Pulkkinen P, Riska EB. (1996) Cancer risk after metal on metal and polyethylene on metal total hip arthroplasty. *Clin Orthop Relat Res* 329 Suppl:S280-9.
- Vundelinckx BJ, Verhelst LA, De Schepper J. (2013) Taper corrosion in modular hip prostheses: analysis of serum metal ions in 19 patients. *J Arthroplasty* 28:1218-23.
- Wagner P, Olsson H, Ranstam J, Robertsson O, Zheng MH, Lidgren L. (2012) Metal-on-metal joint bearings and hematopoietic malignancy. *Acta Orthop* 83:553-8.
- Wamper KE, Sierevelt IN, Poolman RW, Bhandari M, Haverkamp D. (2010) The Harris hip score: Do ceiling effects limit its usefulness in orthopedics?. *Acta Orthop* 81:703-7.
- van der Weegen W1, Hoekstra HJ, Sijbesma T, Austen S, Poolman RW. (2012) Hip resurfacing in a district general hospital: 6-year clinical results using the ReCap hip resurfacing system. *BMC Musculoskelet Disord.* 13;247-56.
- Watters TS, Cardona DM, Menon KS, Vinson EN, Bolognesi MP, Dodd LG. (2010) Aseptic lymphocyte-dominated vasculitis-associated lesion: a clinicopathologic

- review of an underrecognized cause of prosthetic failure. *Am J Clin Pathol* 134:886-93.
- Whitehouse MR, Aquilina AL, Patel S, Eastaugh-Waring SJ, Blom AW. (2013) Survivorship, patient reported outcome and satisfaction following resurfacing and total hip arthroplasty. *J Arthroplasty*. 28:842-8.
- Widmer KH. (2004) A simplified method to determine acetabular cup anteversion from plain radiographs. *J Arthroplasty* 19:387-90.
- Wiles P. (1958) The surgery of the osteoarthritic hip. *Br J Surg*. 45:488-97
- Willert HG, Buchhorn GH, Fayyazi A. (2005) Metal-on-metal bearings and hypersensitivity in patients with artificial hip joints. A clinical and histomorphological study. *J Bone Joint Surg Am* 87:28-36.
- Williams D, Royle M, Norton M. (2009) Metal-on-metal hip resurfacing: the effect of cup position and component size on range of motion to impingement. *J Arthroplasty* 24:144-51.
- Williams DH, Greidanus NV, Masri BA, Duncan CP, Garbuz DS. (2012) Predictors of participation in sports after hip and knee arthroplasty. *Clin Orthop Relat Res* 470:555-61.
- Wilson JN, Scales JT. (1970) Loosening of total hip replacements with cement fixation. Clinical findings and laboratory studies. *Clin Orthop Relat Res* 72:145-60.
- Woon RP, Johnson AJ, Amstutz HC. (2013) The results of metal-on-metal hip resurfacing in patients under 30 years of age. *J Arthroplasty* 28:1010-4.
- Yao L, Yao J, Gold RH. (1995) Measurement of acetabular version on the axiolateral radiograph. *Clin Orthop Relat Res* 316:106-11.
- Yoo JJ, Kim YM, Yoon KS. (2006) Contemporary alumina-on-alumina total hip arthroplasty performed in patients younger than forty years: a 5-year minimum follow-up study. *J Biomed Mater Res B Appl Biomater* 2006;78:70-5.

Original publications