



SYNNÖVE STAFF

Somatic Genetic Changes  
of BRCA1 and BRCA2  
in Breast Cancer



ACADEMIC DISSERTATION

To be presented, with the permission of  
the Faculty of Medicine of the University of Tampere,  
for public discussion in the auditorium of Finn-Medi 1,  
Lenkkeilijänkatu 6, Tampere, on June 6th, 2003, at 12 o'clock.

*Acta Universitatis Tampereensis 938*  
*University of Tampere*  
*Tampere 2003*

ACADEMIC DISSERTATION

University of Tampere, Institute of Medical Technology  
Finland

Supervised by  
Professor Jorma Isola  
University of Tampere  
Docent Minna Tanner  
University of Tampere

Reviewed by  
Docent Anne Kallioniemi  
University of Tampere  
Docent Heli Nevanlinna  
University of Helsinki

Distribution



University of Tampere  
Bookshop TAJU  
P.O. Box 617  
33014 University of Tampere  
Finland

Tel. +358 3 215 6055  
Fax +358 3 215 7685  
taju@uta.fi  
<http://granum.uta.fi>

Cover design by  
Juha Siro

Printed dissertation  
Acta Universitatis Tamperensis 938  
ISBN 951-44-5686-6  
ISSN 1455-1616

Electronic dissertation  
Acta Electronica Universitatis Tamperensis 261  
ISBN 951-44-5687-4  
ISSN 1456-954X  
<http://acta.uta.fi>

Tampereen yliopistopaino Oy Juvenes Print  
Tampere 2003

## Contents

<b>List of original communications</b> .....	5
<b>Abbreviations</b> .....	6
<b>Abstract</b> .....	8
<b>Introduction</b> .....	10
<b>Review of the literature</b> .....	11
<b>1. Cancer</b> .....	11
1.1. Oncogenes.....	11
1.2. Tumor suppressor genes.....	12
1.2.1. Knudson's two-hit hypothesis.....	12
1.2.2. Gatekeepers and caretakers.....	13
<b>2. Breast cancer</b> .....	14
2.1. Hereditary breast cancer.....	14
<b>3. BRCA1 and BRCA2 genes</b> .....	16
3.1. Structure and expression pattern.....	16
3.2. Mutations.....	17
3.3. Functions of BRCA1 and BRCA2.....	19
3.3.1. BRCA1.....	20
3.3.2. BRCA2.....	22
3.4. Tissue-specificity of cancer predisposition.....	24
3.5. Hereditary breast cancers associated with <i>BRCA1</i> and <i>BRCA2</i> mutations.....	25
<b>4. BRCA1 and BRCA2 in sporadic breast cancer</b> .....	27
4.2. Expression of BRCA1 and BRCA2.....	27
4.3. LOH at <i>BRCA1</i> and <i>BRCA2</i> .....	28
4.4. Promoter hypermethylation.....	28
<b>Aims of the study</b> .....	30
<b>Materials and methods</b> .....	31
<b>1. Tumor material</b> .....	31
1.1. Hereditary breast tumors.....	31
1.2. Sporadic breast tumors.....	32
1.3. Breast cancer cell line.....	33
<b>2. Methods</b> .....	33
2.1. Fluorescence in situ hybridization (FISH) (I-IV).....	33
2.1.1. Probes.....	33
2.1.2. Hybridization.....	34
2.1.3. Fluorescence microscopy.....	34
2.2. Allelic imbalance by microsatellite analysis (I, II).....	35
2.3. DNA methylation (III).....	36
2.4. Preparation of the xenograft and cell line (IV).....	36
2.5. Cytogenetic analyses of the xenograft and cell line (IV).....	37
2.6. Histopathological, tumor biological and mutation analyses (III, IV).....	37
2.7. Expression of BRCA1 (III, IV).....	38

## CONTENTS

2.7.1. RNA extraction and cDNA synthesis (III, IV).....	38
2.7.2. Qualitative RT-PCR (IV).....	38
2.7.3. Quantitative real-time RT-PCR (III).....	40
2.7.4. Immunoprecipitation and western blotting (IV).....	42
2.8. Gene expression profiling by cDNA microarrays (IV).....	42
2.9. Statistical analyses (I-IV).....	43
<b>Results</b> .....	<b>44</b>
<b>1. Allelic imbalance and gene copy number changes (I, II)</b> .....	<b>44</b>
1.1. Hereditary breast tumors (I, II).....	44
1.1.1. BRCA1 tumors (I, II).....	44
1.1.2. BRCA2 tumors (I, II).....	46
1.2. Sporadic breast tumors (I).....	48
<b>2. Concomitant loss of the <i>BRCA1/2</i> genes (II)</b> .....	<b>49</b>
<b>3. <i>BRCA1</i> deletions, promoter hypermethylation and expression in sporadic breast cancers (III)</b> .....	<b>49</b>
3.1. <i>BRCA1</i> deletions (III).....	50
3.2. Promoter hypermethylation (III).....	51
3.3. Regression model of full-length BRCA1 mRNA expression (III).....	51
<b>4. Preparation of the xenograft and cell line (IV)</b> .....	<b>51</b>
4.1. Analysis of the <i>BRCA1</i> gene status (IV).....	52
4.2. Karyotype analysis (IV).....	52
4.3. Histopathology and tumor biological characteristics (IV).....	52
4.4. Expression analyses of the xenograft and cell line (IV).....	53
4.4.1. Expression of BRCA1 mRNA and BRCA1 protein (IV).....	53
4.4.2. Gene expression profiling (IV).....	54
<b>Discussion</b> .....	<b>55</b>
<b>1. Mechanisms for allelic imbalance (I, II)</b> .....	<b>55</b>
<b>2. Multiple mutant copies of the <i>BRCA1/2</i> genes (I)</b> .....	<b>58</b>
<b>3. Concomitant loss of <i>BRCA1</i> and <i>BRCA2</i> (II)</b> .....	<b>60</b>
<b>4. Haplo-insufficiency of <i>BRCA1</i> in sporadic breast cancer (III)</b> .....	<b>61</b>
<b>5. Characterization of BRCA1 null xenograft and cell line (IV)</b> .....	<b>65</b>
<b>Conclusions</b> .....	<b>67</b>
<b>Acknowledgements</b> .....	<b>68</b>
<b>References</b> .....	<b>70</b>
<b>Original communications</b> .....	<b>84</b>

## List of original communications

This thesis is based on the following communications, which are referred to in the text by their Roman numerals.

I. Staff S, Nupponen NN, Borg A, Isola JJ, Tanner MM (2000): Multiple copies of mutant BRCA1 and BRCA2 alleles in breast tumors from germ-line mutation carriers. *Genes Chromosomes Cancer* 28:432-42.

II. Staff S, Isola JJ, Johannsson O, Borg A, Tanner MM (2001): Frequent somatic loss of BRCA1 in breast tumors from BRCA2 germ-line mutation carriers and vice versa. *Br J Cancer* 85:1201-5.

III. Staff S, Isola J, Tanner M (2003): Haplo-insufficiency of *BRCA1* in sporadic breast cancer. Submitted to *Cancer Research*.

IV. Johannsson OT, Staff S, Vallon-Christersson J, Kytölä S, Gudjonsson T, Rennstam K, Hedenfalk IA, Adeyinka A, Kjellén E, Wennerberg J, Baldetorp B, Petersen OW, Olsson H, Oredsson S, Isola J, Borg Å (2003): Characterization of a novel breast carcinoma xenograft and cell line derived from a *BRCA1* germ-line mutation carrier. *Lab Invest*, 83:387-96.

## ABBREVIATIONS

### Abbreviations

AI	Allelic imbalance
APC	Adenomatous polyposis coli
AR	Androgen receptor
ATM	Ataxia-telangiectasia mutated
BARD1	BRCA1 associated RING domain 1
BASC	BRCA1-associated genome surveillance complex
BLM	Bleomycin, Bloom syndrome
bp	Base pair
BRC	Repeats in BRCA2 gene
BRCA1	Breast cancer susceptibility gene 1
BRCA1-delta11b	BRCA1 splice variant lacking most of exon 11
BRCA1-HBC	BRCA1-mutation associated hereditary breast cancer
BRCA2	Breast cancer susceptibility gene 2
BRCA2-HBC	BRCA2-mutation associated hereditary breast cancer
BRCT	BRCA1 C-terminal
cDNA	Complementary deoxyribonucleic acid
CGH	Comparative genomic hybridization
CHK2	Checkpoint homolog (S.pombe)
CpG	Cytosine-guanine dinucleotide
DAPI	4',6-diamino-2-phenylindole
DNA	Deoxyribonucleic acid
dNTP	Deoxynucleoside triphosphate
DSB	Double strand break
dUTP	Dioxyuridine triphosphate
EGFR	Epidermal growth factor receptor
ER	Estrogen receptor
ERBB2	Avian erythroblastic leukemia viral oncogene homolog 2
ETB	Endothelin receptor type B
FISH	Fluorescence in situ hybridization
FITC	Fluorescein isothiocyanate
GADD45	Growth arrest and DNA-damage-inducible
HR	Homologous recombination
kb	Kilobase pairs
kDa	Kilodalton
LOH	Loss of heterozygosity
MLH1	MutL homolog 1
MRE11	MRE11 meiotic recombination 11 homolog (S. cerevisiae)
mRNA	Messenger ribonucleic acid
MSH2	MutS homolog 2
MSH6	MutS homolog 6
MYB	Avian myeloblastosis viral oncogene homolog
MYC	Avian myelocytomatosis viral oncogene homolog
Nbs1	Nijmegen breakage syndrome 1
NF-1	Neurofibromatosis type 1
NLS	Nuclear localization sequence
P/CAF	p300/CBP-associated factor
PAC	P1-derived artificial chromosome
PCR	Polymerase chain reaction
PgR	Progesterone receptor
RAD50	RAD50 homolog (S. cerevisiae)

## ABBREVIATIONS

RAD51	RAD51 homolog (RecA homolog, E. coli) ( <i>S. cerevisiae</i> )
RB1	Retinoblastoma 1
RNA	Ribonucleic acid
RT-PCR	Reverse-transcriptase polymerase chain reaction
SDS	Sodium dodecyl sulfate
SKY	Spectral karyotyping
SSC	Sodium chloride-sodium citrate
SWI/SNF	<i>S. cerevisiae</i> homologs, mating type <u>sw</u> itching and <u>suc</u> rose <u>non</u> fermenting
TP53	Tumor protein p53
TS	Tumor suppressor
ZBRK1	Zinc finger and BRCA1-interacting protein with a KRAB domain 1

## Abstract

Somatic genetic re-arrangements of breast cancer susceptibility genes, *BRCA1* and *BRCA2*, were investigated in hereditary and sporadic breast carcinomas using allelic imbalance (AI) analysis with microsatellite markers and fluorescence in situ hybridization (FISH). Quantitative real-time RT-PCR was used to study *BRCA1* gene expression and its relation to somatic genetic re-arrangements and promoter hypermethylation in sporadic breast cancer. Experimental mouse xenograft (L56Br-X1) and cell line (L56Br-C1) models were established for future purposes of studying *BRCA1* function and therapeutical aspects of *BRCA1* tumors.

AI at *BRCA1* and *BRCA2* was detected in majority of breast tumors from germ-line *BRCA1* and *BRCA2* mutation carriers, respectively. Concomitant loss of *BRCA1* and *BRCA2* gene copies was more frequent in hereditary than sporadic breast cancers (71% vs. 29%). AI at *BRCA1/2* loci in hereditary breast tumors from germ-line *BRCA1* mutation carriers resulted not only from physical deletions but also from alternative mechanisms such as non-disjunction or somatic recombination, whereas AI at *BRCA1/2* loci in sporadic tumors was predominantly due to physical deletions. Multiple copies of mutant *BRCA1* alleles were detected in many hereditary *BRCA1* tumors.

The *BRCA1* gene had undergone physical deletion in 45% of the sporadic breast tumors studied. Physical deletion of the gene was associated with *ERBB2* oncogene amplification, aneuploidy and decreased expression of both full-length *BRCA1* and *BRCA1*-delta11b splice variant mRNA. Eleven percent of the sporadic breast carcinomas showed *BRCA1* promoter hypermethylation, which associated with low levels of both full-length and *BRCA1*-delta11b mRNA, but not with *BRCA1* deletions or any clinico-pathological feature of the tumors. In multiple regression analysis, the strongest determining factor for the full-length *BRCA1* mRNA level was *BRCA1* deletion, followed by negative progesterone receptor (PgR) status and *BRCA1* promoter hypermethylation. These three factors explained ca. 45% of the total variation in *BRCA1* gene expression. The expression levels of full-length *BRCA1* and *BRCA1*-delta11b mRNA showed strong correlation with each other.

A mouse xenograft, L56Br-X1, was established from a breast cancer axillary node metastasis of a 53-year-old woman with a *BRCA1* germ-line nonsense mutation (1806C→T; Gln563Stop), and subsequently a cell line (L56Br-C1) was derived from the xenograft. The L56Br-X1 xenograft carried only the mutant *BRCA1* allele, and expressed mutant *BRCA1* mRNA, but no *BRCA1* protein. Cytogenetic analyses of the L56Br-X1



xenograft and L56Br-C1 cell line revealed complex karyotypes with numerous unbalanced translocations. Both L56Br-X1 xenograft and L56Br-C1 cell line showed the *p53* somatic missense mutation (Ser215Ile) of the primary tumor, as well as a lack of detectable expression of ER, PgR, EGFR and ERBB2 by immunostaining. Gene expression profiling by cDNA microarrays supported the similarity of the expression profiles between the L56Br-X1 xenograft, L56Br-C1 cell line and primary tumor.

Our results support the role of the *BRCA1/2* genes as tumor suppressors in hereditary breast cancer. Mechanisms alternative to deletions leading to AI in *BRCA1* breast tumors suggest that specific pathways, such as recombinational repair, may be defective specifically in this tumor type. Multiple mutant *BRCA1* alleles may reflect dominant negative function of certain *BRCA1* mutants in tumor formation. The association of *BRCA1* deletions with low levels of *BRCA1* mRNA suggests that *BRCA1* may be involved in sporadic breast cancer through haplo-insufficiency. *BRCA1* was down-regulated in sporadic breast cancer tumors mainly by physical deletion and also by promoter hypermethylation in a small proportion of tumors. Multiple regression analysis indicated that almost half of the total variation in *BRCA1* expression in sporadic breast cancer was due to *BRCA1* gene copy number variation and promoter hypermethylation. The strong correlation between *BRCA1* full-length and delta11b variant mRNA levels suggests that they may be co-expressed in sporadic breast carcinomas. L56Br-X1 xenograft and L56Br-C1 cell line derived from *BRCA1* breast cancer did retain close resemblance to the primary tumor. Thus, they can be used as experimental model systems for future studies on *BRCA1* function, pathogenesis and treatment of *BRCA1* breast cancer.

## Introduction

Breast cancer is the most common female malignancy in western countries. In Finland, more than 3500 women are affected with the disease every year and the incidence of breast cancer has been estimated to even increase in the future (Finnish Cancer Registry 2000). Breast cancer is due to both environmental and genetic factors, but positive family history is the strongest risk factor. Ca. 5-10% of breast cancer is hereditary showing Mendelian inheritance pattern and associating with early onset, bilateral disease and cancers at other sites. Approximately 20% of breast cancers show familial aggregation without obvious Mendelian inheritance. In 1994 and 1995, major findings regarding breast cancer genetics were accomplished by the cloning of two major breast cancer susceptibility genes, *BRCA1* (Miki et al. 1994) and *BRCA2* (Wooster et al. 1995, Tavtigian et al. 1996). Inherited mutations in the *BRCA1/2* genes account for most of breast cancers occurring in families of early-onset breast and ovarian cancers, but only minority of hereditary site-specific breast cancers (reviewed in Nathanson and Weber 2001). Somatic *BRCA1/2* mutations are rare (Futreal et al. 1994, Teng et al. 1996), and thus, the role of these genes in sporadic breast cancer has remained unexplained.

As all human malignancies, both sporadic and inherited breast cancers can be regarded as genetic diseases, since they all are derived from a single cell, in which genetic alterations have been accumulated to let the cell escape from normal growth restrictions. Cytogenetic and molecular genetic analyses of breast cancer tumors have revealed genetic heterogeneity, complex patterns of genetic alterations and thus, genomic instability (reviewed in Beckmann et al. 1997, and Ingvarsson 1999). One of the main aims of genetic studies of breast cancer can be seen as to achieve a better understanding of the fundamental genetic alterations leading to malignant tumor initiation and promotion. If these genetic aberrations could be detected and the genes involved identified, targeted molecular treatments could be designed, rendering the therapy of cancer patients more accurate and effective. The purpose of this study parallels to this general idea of a detailed analysis of genetic re-arrangements and mechanisms of tumor suppressor gene inactivation in breast cancer. More specifically, the aim of this study was to investigate the somatic inactivation mechanisms of the *BRCA1* and *BRCA2* genes in both hereditary and sporadic breast cancer tumors.

## Review of the literature

### 1. Cancer

Cancer is a genetic disease evolving from a single cell, which has acquired a sufficient amount of mutations in critical genes controlling cell division or cell death. Cultured normal human fibroblasts and epithelial cells have been transformed into malignant cells by introducing a combination of three genetic elements affecting important cellular pathways (Hahn et al. 1999, Seger et al. 2002) as opposed to two genetic changes required to transform mouse cells (Land et al. 1983). The model for multistep evolution of human cancer is provided from the studies of colorectal cancer, in which mutations accumulate along the progression of the disease (reviewed in Fearon and Vogelstein 1990). Furthermore, it has been suggested that in the process of transformation a human cell must undergo at least six genetic alterations leading to a defect in essential pathways controlling normal cellular physiology. Thus, any cell developing into a malignant one needs to become self-sufficient in growth signals, insensitive to anti-growth signals, evade apoptosis, sustain angiogenesis, gain limitless replicative potential and acquire potential for tissue invasion and subsequent metastasis (reviewed in Hanahan and Weinberg 2000). In other words, malignant process requires that proto-oncogenes, usually controlling positively growth, become activated and turn into oncogenes. Conversely, genes inhibiting growth or controlling DNA repair, i.e. tumor suppressors, become inactivated.

#### 1.1. Oncogenes

Proto-oncogenes are normal cellular genes, which regulate growth (e.g. *PDGF*, secreted growth factor; *ERBB* gene family, cell surface receptors), take part in intracellular signaling pathways (e.g. *ABL*, *RAS* gene family), control transcription of other genes (e.g. *MYC*) or control progression of cell cycle (e.g. *MDM2*, *CCND1*) (reviewed in Schwab 1998). Oncogenes are activated by gain-of-function mutations leading to cancer progression. Activation of oncogenes can be the result of gene amplification, and, in fact, *MYC* and *ERBB2* are often amplified in breast cancer (Borg et al. 1991, Rummukainen et al. 2001). Oncogenes can also be activated by point mutations, of which *RAS* gene provides an example in various types of tumors (Bos et al. 1987, Suzuki et al. 1990), and by chromosomal translocations, which can produce either novel chimeric genes functioning abnormally (e.g. *ABL-BCR* fusion gene in chronic myeloid leukemia (Shtivelman et al.

1985)) or put oncogenes in a chromosomal environment of active transcription (e.g. *MYC* in Burkitt's lymphoma (Taub et al. 1982)).

## **1.2. Tumor suppressor genes**

Cell fusion experiments have shown that transformed phenotypes can be corrected *in vitro* by fusion of the transformed cell with a normal cell indicating the presence of genes that control negatively growth (Harris et al. 1969). These genes are called tumor suppressor (TS) genes and they are inactivated by recessive, loss-of-function mutations. Identification of TS genes has been mainly achieved by positional cloning of genes causing rare inherited cancer syndromes or by defining chromosomal locations commonly deleted in tumor cells using loss of heterozygosity (LOH) or allelic loss studies or comparative genomic hybridization (CGH). TS genes are often involved in cell cycle control (e.g. *RBI*, *p53*, *BRCA1*, *BRCA2*), in transcriptional control (e.g. *p53*, *BRCA1*, *BRCA2*, *APC*), in repair of damaged DNA (e.g. *BRCA1*, *BRCA2*, *MLH1*, *MSH2*, *MSH6*) or in negative regulation of signaling pathways (e.g. *NF-1*) (reviewed in Macleod 2000).

### **1.2.1. Knudson's two-hit hypothesis**

Retinoblastoma is a rare childhood eye tumor that AG Knudson studied using epidemiological approach and based on these studies he proposed the so-called two-hit hypothesis (Knudson 1971). According to this theory, two inactivating 'hits', i.e. mutations, are needed in transformation of a normal cell. Thus, patients of hereditary retinoblastoma syndrome have inherited the first 'hit' as a germ-line mutation in the *RBI* gene, but in order to develop retinoblastoma, the wild-type allele has to be inactivated as well. Because these patients have inherited the first 'hit', they are prone to early-onset or bilateral retinoblastoma compared to healthy individuals who have to acquire both inactivating *RBI* mutations ('hits') within one cell during their lifetime. Knudson's theory was confirmed by studies of sporadic retinoblastoma where markers at *RBI* locus on chromosome 13 were compared between blood and tumor tissue from the same patients. These analyses revealed that blood samples were heterozygous for chromosome 13 markers whereas tumor samples had lost their heterozygosity i.e. become homozygous (LOH) (Cavenee et al. 1983). These findings were considered as a proof of Knudson's first hit, a loss of one functional copy of a TS gene. Furthermore, studies of hereditary retinoblastoma have showed that the lost copy detected by LOH is always the wild-type allele (Cavenee et al. 1985). The possible mechanisms leading to LOH at a TS locus are summarized in Figure 1.

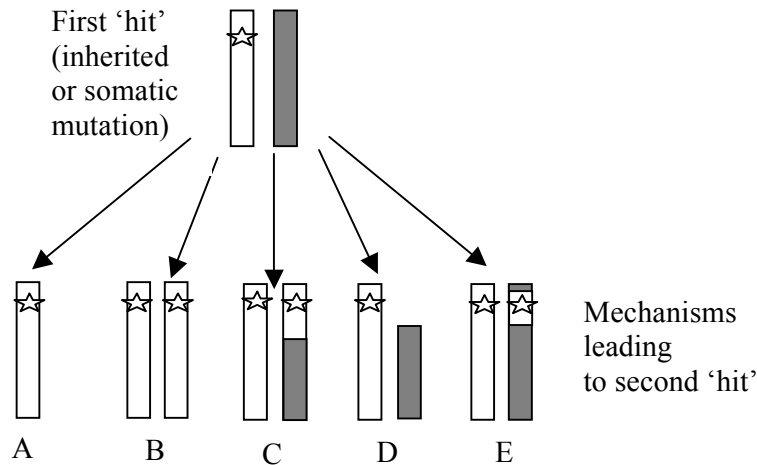

**Figure 1.** Chromosomal mechanisms resulting in LOH at a TS locus. Open rectangle indicates paternally and grey rectangle maternally inherited chromosome. A star can be interpreted as either an inherited or somatic mutation. LOH can result from non-disjunction without reduplication (A) or with reduplication (B), from mitotic recombination with segregation of both mutation-bearing chromosomes into the same daughter cell (C), from deletion (D) or from other mechanisms inactivating the remaining chromosome locus (E) such as gene conversion. Modified from Cavenee et al. 1986.

Other mechanisms can also result in inactivation of a TS gene besides the ones leading to LOH. The first 'hit' can be followed also by epigenetic silencing of the remaining allele by promoter hypermethylation (reviewed in Jones and Laird 1999) and despite the functional inactivation of both alleles of the TS gene, LOH can not be detected. In fact, inactivation of many TS genes by epigenetic silencing have been shown to occur in the process of tumor formation (reviewed in Esteller 2002). Alternatively, inactivation of only one TS gene copy (Knudson's first 'hit') could confer a selective advantage to cells, which can be interpreted as the TS gene being haplo-insufficient (Cook and McCaw 2000, Quon and Berns 2001). In fact, TS genes *Dmp1*, *NF-1* and *APC* have been described to be haplo-insufficient for tumor suppression (Inoue et al. 2001, Kemkemer et al. 2002, Yan et al. 2002) indicating that Knudson's prevailing paradigm for tumor suppressor function may have to be revised.

### 1.2.2. Gatekeepers and caretakers

A model has been described where TS genes are divided into two categories, gatekeepers and caretakers (Kinzler and Vogelstein 1997). According to this model, gatekeepers directly regulate growth of tumors by inhibiting growth or accelerating death. Thus, inactivating mutations in these genes are rate-limiting for tumor initiation, which requires inactivation of both maternal and paternal copies of the gatekeeper gene but not any additional mutations in other genes. Caretaker TS genes are suggested to be the so-called

## REVIEW OF THE LITERATURE

guardians of the genome. Inactivation of both caretaker alleles is suggested to lead to instability of the genome but not directly initiation of neoplasia. The genomic instability as such renders cells prone to additional genetic changes in other genes (also in gatekeepers), which then subsequently leads to malignancy. Thus, it has been speculated that very early-onset hereditary cancer syndromes are associated with inherited mutations in the gatekeeper genes and it would be also more likely that sporadic tumors exhibited somatic mutations in these genes (e.g. *p53*, *RBI*, *NF-1*, *APC*). In contrast, caretaker genes would be then responsible for inherited cancer syndromes manifesting later in life (e.g. *BRCA1*, *BRCA2*). Moreover, involvement of somatic mutations in the caretaker genes leading to sporadic cancer would be improbable, since more mutations in number would be required in the caretaker 'pathway'.

## **2. Breast cancer**

Breast cancer is the most common female malignancy in western countries and it is also the most common cause of female cancer mortality. In year 2000, 3665 new breast cancers were diagnosed in Finland and the incidence of breast cancer is further rising (Finnish Cancer Registry 2000). Breast cancer is due to both environmental and genetic factors (reviewed in Henderson 1993, Henson and Tarone 1994). Most risk factors for breast cancer, such as early menarche, late age at first childbirth and menopause, nulliparity, obesity or exposure to ionizing radiation, are generally associated with moderate increase in risk (reviewed in Feigelson and Henderson 1996). In contrast, patients with a family history of breast cancer at young age and with many family members affected are at high risk (Pharoah et al. 1997). However, only a minority of women belongs to this group of high risk. Only 5-10% of breast cancer is hereditary associated with early onset, bilateral disease and cancer at other sites and approximately 10-20% of breast cancer is familial associated with two or three family members of breast cancer (Lynch et al. 1984, Claus et al. 1991). While hereditary breast cancers are due to inherited mutations in highly penetrant susceptibility genes, familial breast cancer may be due to genes of low penetrance or clustering of unknown environmental factors or chance (Lynch et al. 1989).

### **2.1. Hereditary breast cancer**

Hereditary breast cancers show Mendelian autosomal dominant pattern of inheritance (reviewed in Rebbeck 1999). Most, if not all, of the susceptibility for both inherited breast and ovarian cancer syndrome is due to germ-line mutations in the two major breast cancer susceptibility genes, *BRCA1* and *BRCA2* (Miki et al. 1994, Wooster et al. 1995, reviewed in

Nathanson and Weber 2001). However, only a small proportion of hereditary site-specific breast cancer risk can be explained by *BRCA1/2* mutations suggesting that other susceptibility genes remain to be discovered (*BRCAx*) (Schubert et al. 1997, Serova et al. 1997, Vehmanen et al. 1997a, Ford et al. 1998, Antoniou et al. 2001). Even very early-onset breast cancer without association with ovarian cancer is mostly due to other genetic factors than germ-line mutations in the *BRCA1/2* genes (Ford et al. 1998, Peto et al. 1999, Loman et al. 2001). A truncating variant of *CHEK2* (previously *CHK2*) has been recently reported to confer low-penetrance susceptibility to breast cancer in families not carrying mutations in *BRCA1* or *BRCA2* (Meijers-Heijboer et al. 2002, Vahteristo et al. 2002). Rare cancer syndromes also account for a small proportion of hereditary breast cancers. Inherited mutations in the *p53* gene cause Li-Fraumeni syndrome associated with early-onset and bilateral breast tumors and other tumors (such as sarcomas, brain tumors, leukemia) (Malkin et al. 1990). Cowden syndrome is due to mutations in the *PTEN* gene and is manifested by increased incidence of tumors of thyroid, breast, skin and gastrointestinal tract (Liaw et al. 1997, Tsou et al. 1997). Additionally, hereditary syndromes like Peutz-Jeghers (Boardman et al. 1998) and ataxia-telangiectasia associated with mutations in the *ATM* gene (Olsen et al. 2001) are associated with an increased risk of breast cancer. An overview of etiology of breast cancer is shown in Figure 2.

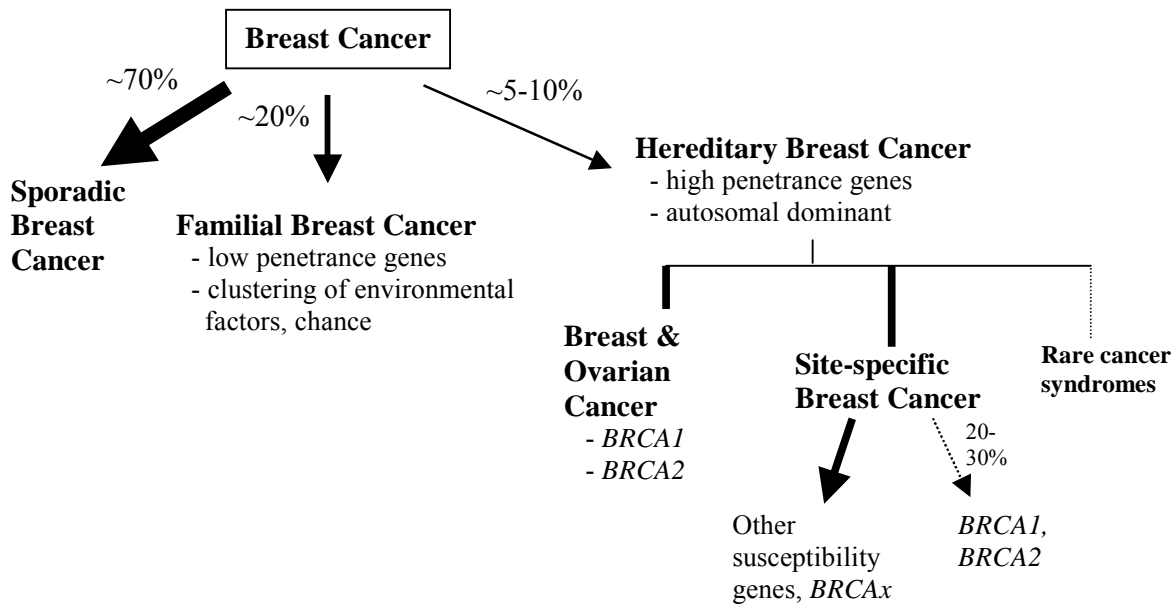

**Figure 2.** Schematic presentation of etiology of breast cancer.

### **3. BRCA1 and BRCA2 genes**

#### **3.1. Structure and expression pattern**

*BRCA1* gene at 17q21 was cloned in 1994 (Miki et al. 1994). The *BRCA1* gene consists of 24 exons, of which 22 are coding, spanning over 70 kb of genomic DNA. The central exon 11 corresponds to over 50% of the *BRCA1* coding region. The mRNA transcript of *BRCA1* is 7.8 kb and it encodes a nuclear protein of 1863 amino acids and molecular weight 220 kDa (Miki et al. 1994, Chen et al. 1996). *BRCA1* has several common splice variants, of which the most studied is *BRCA1*-delta11b lacking most of the central exon 11 (Miki et al. 1994, Lu et al. 1996, Wilson et al. 1997). *BRCA2* gene at 13q12 was cloned in 1995 and completely sequenced in 1996 (Wooster et al. 1995, Tavtigian et al. 1996). *BRCA2* consists of 26 coding exons. *BRCA2* mRNA transcript is 11.2 kb and it encodes a nuclear protein of 3418 amino acids and molecular weight 384 kDa (Tavtigian et al. 1996, Bertwistle et al. 1997). Genomic regions of *BRCA1/2* genes have high density of repetitive elements (reviewed in Welch et al. 2000).

*BRCA1/2* mRNA is expressed in a wide range of tissues but predominantly in testis and thymus (Miki et al. 1994, Tavtigian et al. 1996). In developing mouse embryos, expression of *BRCA1/2* genes is co-regulated and at highest levels in rapidly proliferating cells and in differentiating mammary epithelial cells (Rajan et al. 1996, Rajan et al. 1997). Both *BRCA1* and *BRCA2* are expressed at high levels in mouse mammary gland also during puberty and pregnancy (Rajan et al. 1997). Expression patterns of *BRCA1/2* mRNA and protein are cell-cycle dependent peaking at G1-S and G2-M (Chen et al. 1996, Gudas et al. 1996, Rajan et al. 1996, Wang et al. 1997, Xu et al. 1999b).

*BRCA1* and *BRCA2* show no sequence homology to other known proteins but some conserved domains have been identified providing some clues to their functions (Figure 3). *BRCA1* has an N-terminal RING (a specialized type of Zn-finger) domain, which can mediate protein-DNA or protein-protein interactions (Miki et al. 1994, Koonin et al. 1996). *BRCA1* interacts through its RING domain with *BARD1*, also a RING finger containing protein (Wu et al. 1996). *BRCA1*-*BARD1* complex is suggested to take part in ubiquitination (reviewed in Welch et al. 2000). Both *BRCA1* and *BRCA2* have nuclear localization sequences (NLS) and transactivation domains (Chapman and Verma 1996, Milner et al. 1997). *BRCA1* and *BRCA2* include regions of conserved repeated sequences. BRCT (*BRCA1* C-terminal) repeats are motifs often identified in proteins involved in DNA repair or metabolism (Callebaut and Mornon 1997). Exon 11 of *BRCA2* consists of BRC



repeats, which are conserved across mammalian BRCA2 proteins and which mediate interaction with RAD51 (Wong et al. 1997).

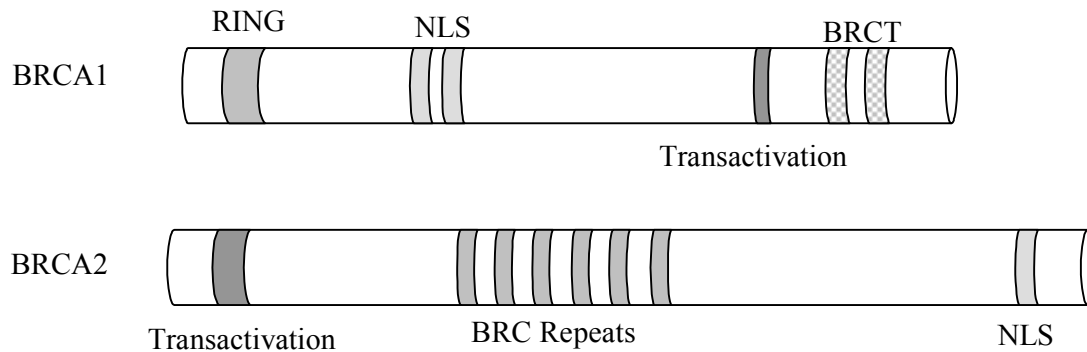

**Figure 3.** Functional domains of BRCA1 and BRCA2. (NLS = nuclear localization sequence, BRCT = BRCA1 C-terminal repeats, BRC = repeat sequences in BRCA2 exon 11)

Interestingly, *BRCA1* and *BRCA2* genes have numerous similarities even if the genes are not related by sequence. Both genes are large and contain large central exons (exon 11). Both are putative tumor suppressor genes since tumors in germ-line mutation carriers show LOH at *BRCA1/2* loci (Smith et al. 1992, Neuhausen and Marshall 1994, Collins et al. 1995, Gudmundsson et al. 1995). Furthermore, they both encode nuclear proteins of cell cycle dependent expression pattern and co-localize in various tissues during proliferation and differentiation (Zhang et al. 1998b). Both BRCA1/2 proteins have also putative transcriptional activation domains (Chapman and Verma 1996, Milner et al. 1997). Most knockout *BRCA1*<sup>-/-</sup> or *BRCA2*<sup>-/-</sup> mice die in early embryonic development and suffer from severe proliferation defects (Ludwig et al. 1997). Finally, somatic mutations in either *BRCA1* or *BRCA2* gene are practically absent in sporadic breast cancers (Futreal et al. 1994, Miki et al. 1996).

### 3.2. Mutations

Several hundred different mutations and sequence variants have been described for both of the *BRCA1/2* genes (Breast Cancer Information Core; [http://www.nhgri.nih.gov/Intramural\\_research/Lab\\_transfer/Bic/](http://www.nhgri.nih.gov/Intramural_research/Lab_transfer/Bic/)). Mutations are scattered throughout the coding sequences of the *BRCA1/2* genes revealing no mutational hotspots and indicating that all parts of BRCA1 and BRCA2 proteins may be important for tumor suppression. Disease-associated mutations are mostly frameshift and nonsense mutations leading to premature stop codon in the transcript and thus truncated BRCA1/2 proteins. Missense mutations abrogating critical domains (e.g. RING and BRCT) have also been

## REVIEW OF THE LITERATURE

described for *BRCA1* (Thai et al. 1998, Williams and Glover 2002). However, the relevance of *BRCA1/2* missense variants is still unclear (Couch and Weber 1996, Wagner et al. 1999). The carrier frequency of *BRCA1* or *BRCA2* mutations in general population has been estimated approximately 0.05-0.1% (Ellisen and Haber 1998, Antoniou et al. 2002) but among some ethnic groups the prevalence of *BRCA1/2* mutations is higher (e.g. 185delAG and 5382insC in *BRCA1* or 6174delT in *BRCA2* in Ashkenazi Jews and 999del5 in *BRCA2* in Icelanders) (Roa et al. 1996, Struewing et al. 1997, Thorlacios et al. 1997, Fodor et al. 1998).

In Finland, approximately 30 different mutations in the *BRCA1/2* genes have been described (Vehmanen et al. 1997a, Vehmanen et al. 1997b, Huusko et al. 1998, Syrjäkoski et al. 2000, Vahteristo et al. 2001) and ca. one third of them account for majority of the mutations identified (Vehmanen et al. 1997a, Vehmanen et al. 1997b, Huusko et al. 1998). Among unselected breast cancer patients, the prevalence of *BRCA1* and *BRCA2* mutations is very low but the presence of ovarian cancer in the family together with positive family history for multiple cases of early onset breast cancer is a strong indicator for *BRCA1/2* mutations (Syrjäkoski et al. 2000, Vahteristo et al. 2001). The *BRCA1/2* mutation frequencies in different populations are summarized in Table 1.

**Table 1.** The prevalence of *BRCA1* and *BRCA2* mutations.

	<i>BRCA1</i> (%)	<i>BRCA2</i> (%)	Study
<b>General population</b>	0.051	0.068	(Antoniou et al. 2002) <sup>1</sup>
Ashkenazi Jews	1.05 (185delAG) 0.12 (5382insC)	1.05(6174delT)	(Fodor et al. 1998)
	0.8 (185delAG) 0.4 (5382insC)	1.2 (6174delT)	(Struewing et al. 1997)
Icelanders		0.6 (999del5)	(Thorlacios et al. 1997)
<b>Breast cancer patients</b>			
Ashkenazi Jews (all ages)	2.99 (185delAG) 0.75 (5382insC)	2.99 (6174delT)	(Fodor et al. 1998)
	8.3 (both 185delAG, 5382insC)	3.6 (6174delT)	(Warner et al. 1999)
Icelanders (all ages)		10.4 (999del5) 7.7 (999del5)	(Thorlacios et al. 1998) (Thorlacios et al. 1997)
Finnish (all ages)	0.39	1.4	(Syrjäkoski et al. 2000) <sup>2</sup>
Swedish (age <41)	6.8	2.1	(Loman et al. 2001) <sup>3</sup>
English (age <36)	3.5	2.4	(Peto et al. 1999) <sup>3</sup>

1 An estimate derived from epidemiological modeling. 2 Eleven *BRCA1* and eight *BRCA2* mutations previously found in Finnish population were screened. 3 The whole coding sequences of the *BRCA1/2* genes were screened for mutations.

Based on studies of families with multiple affected first- and second-degree relatives with early onset disease (high risk families), *BRCA1* and *BRCA2* mutation carriers were estimated to have very high, up to 85% lifetime risk for developing breast cancer (Ford et al. 1994, Easton et al. 1995, Ford et al. 1998). Significantly lower breast cancer risk (approximately 30-50%) have been estimated for mutation carriers in studies of patients unselected for family history or age at diagnosis (Struewing et al. 1997, Fodor et al. 1998, Thorlacius et al. 1998) (Table 2). In addition to considerable breast cancer risk, both *BRCA1/2* mutation carriers have substantially increased risk of ovarian cancer. Ovarian cancer risk varies depending on the position of the *BRCA1/2* mutation (Thompson and Easton 2001, Thompson and Easton 2002a), and has been estimated to be approximately 16-40% by age 70 (Struewing et al. 1997, Ford et al. 1998, Breast Cancer Linkage Consortium 1999, Brose et al. 2002). Furthermore, *BRCA1* mutation carriers have been reported to have an excessive risk for developing cancers of colon, pancreas, stomach and fallopian tube (Brose et al. 2002, Thompson and Easton 2002b), and *BRCA2* mutations are associated with an elevated risk of prostate and male breast cancer (Thorlacius et al. 1998, Breast Cancer Linkage Consortium 1999, Eerola et al. 2001a, Thompson and Easton 2001).

**Table 2.** Breast cancer risks associated with *BRCA1* and *BRCA2* mutations

Study	Study subjects	Gene	Risk for breast cancer at age 70
(Ford et al. 1994)	High-risk breast cancer families	<i>BRCA1</i>	87%
(Ford et al. 1998)	High-risk breast cancer families	<i>BRCA2</i>	84%
(Struewing et al. 1997)	Ashkenazi Jews (voluntary subjects)	<i>BRCA1/2</i> founder mutations	56%
(Fodor et al. 1998)	Ashkenazi Jews (unselected)	<i>BRCA1/2</i> founder mutations	36%
(Thorlacius et al. 1998)	Icelanders (unselected)	<i>BRCA2</i> (999del5)	35.4%

### 3.3. Functions of *BRCA1* and *BRCA2*

Studies regarding the cellular functions of *BRCA1* and *BRCA2* in breast cancer have been hampered by lack of good model systems. *BRCA1/2* have only mammalian homologs, and majority of mice with targeted homozygous deletions in *BRCA1* or *BRCA2* do not survive (Ludwig et al. 1997), and mice heterozygous for either *BRCA1* or *BRCA2* are not predisposed to any tumors (reviewed in Deng and Scott 2000). Depending on the position of the truncating mutation, some homozygous *BRCA1/2* mutant mice survive to adulthood

## REVIEW OF THE LITERATURE

(Connor et al. 1997, Friedman et al. 1998, Ludwig et al. 2001). These mice develop thymic lymphomas (Connor et al. 1997, Friedman et al. 1998) and also breast carcinomas, which show, however, a great variability in histopathological patterns suggesting stochastic involvement of tumorigenic pathways in their progression (Ludwig et al. 2001). *BRCA1* conditional knockout mutant mice have *BRCA1* mutation specifically in the mammary epithelial cells. These *BRCA1* conditional mice in turn develop mammary tumors, but in stochastic fashion, at relatively low frequency and late in life (Xu et al. 1999a). However, the mammary tumors of *BRCA1* conditional knockout mice mimic human tumors by showing multiple genetic changes and similar histopathology (Dennis 1999, Xu et al. 1999a, Brodie et al. 2001, Weaver et al. 2002).

*BRCA1/2*-deficient mouse embryonic cells have been used to study the functions of the *BRCA1/2* genes, and two *BRCA1/2*-deficient, one *BRCA1* and one *BRCA2*, human cancer cell lines (HCC1937 and Capan-1, respectively) are available for studies of *BRCA1/2* function (Goggins et al. 1996, Tomlinson et al. 1998). *BRCA1/2*-deficient mouse cells and human tumor cells have revealed a complex pattern of gross chromosomal re-arrangements, including deletions and translocations, broken chromosomes and chromatids, triradial and quadriradial structures, all markers of defective mitotic recombination (Tirkkonen et al. 1997a, Tirkkonen et al. 1997b, Patel et al. 1998, Xu et al. 1999b, Yu et al. 2000). Yeast studies have shown that gross chromosomal re-arrangements, such as those detected in *BRCA1/2*-deficient cells, indicate malfunctions in DNA repair or recombination (Chen and Kolodner 1999). Double-strand DNA breaks (DSBs) are precursor lesions for gross chromosomal re-arrangements (Chen et al. 1998a). DSBs are repaired in cells by error-free homologous recombination (HR) or by error-prone non-homologous end joining (NHEJ) or single-strand annealing (SSA) (reviewed in Khanna and Jackson 2001). Evidence is accumulating that *BRCA1/2* genes take part in repair of DSBs by HR (Moynahan et al. 1999, Snouwaert et al. 1999, Moynahan et al. 2001, Tutt et al. 2001, Xia et al. 2001). Thus, inactivation of the *BRCA1/2* genes may lead to defective or inappropriate repair of DSBs and subsequently to genomic instability, a possible connection between *BRCA1/2* functions and tumor formation.

### **3.3.1 BRCA1**

*BRCA1* is rapidly phosphorylated upon DNA damage and replication block in dividing cells (Scully et al. 1997b) by kinases ATM, CHEK2 (after ionizing radiation) and ATR (after UV treatment or replication arrest) (Cortez et al. 1999, Lee et al. 2000, Tibbetts et al. 2000). Differential phosphorylation of *BRCA1* in response to different DNA damaging agents suggests that *BRCA1* may provide a connection between DNA damage-sensing and

response mechanisms (reviewed in Venkitaraman 2002). In fact, BRCA1 has been associated with S and G2 checkpoint control of cell cycle progression and in control of centrosome duplication (Xu et al. 2001). Studies reporting BRCA1-regulated expression of a downstream target of the p53 pathway, a DNA damage response gene *GADD45*, further support the role of BRCA1 in DNA damage sensing and signaling (Harkin et al. 1999). *GADD45* expression is normally repressed by a complex in which BRCA1 associates with a novel transcription factor ZBRK1 (Zheng et al. 2000b). After ionizing radiation, phosphorylation of BRCA1 by ATM relieves *GADD45* repression (Li et al. 2000). Moreover, a number of proteins co-localizes with BRCA1 in a complex called BASC (BRCA1-associated genome surveillance complex). This complex includes several DNA damage response proteins (e.g. MSH2, MSH6, MLH1, ATM), all reported to be involved in recognition of abnormal DNA structures indicating that BASC may act as a sensor of DNA damage (Wang et al. 2000b).

In addition, BRCA1 may have a role in DSB repair that is more proximal to the site of DNA damage. Sites of DNA damage are marked by phosphorylation of certain histones (H2A-X), and BRCA1 migrates to the site of phosphorylated H2A-X (Paull et al. 2000) with its interaction partner MRE11/RAD50/Nbs1-complex containing mammalian homologs of yeast proteins known to be involved in DSB repair (Zhong et al. 1999, Wang et al. 2000b). Furthermore, local activities of BRCA1 at DSB sites are indicated by its interactions with proteins that alter chromatin or DNA structure and thus potentially promote the access of components of DNA repair machinery to the site of DSB (reviewed in Venkitaraman 2002). BRCA1 interacts with chromatin remodeling complex SWI/SNF (Bochar et al. 2000), with regulators of histone acetylation/deacetylation (Yarden and Brody 1999) and with DNA helicases including BLM and BACH1 (Wang et al. 2000b, Cantor et al. 2001).

Many other functions besides DSB repair have also been described for BRCA1, but it is currently unknown how these functions contribute to tumor suppression (reviewed in Venkitaraman 2002). BRCA1 has been suggested to take part in transcription and RNA metabolism due to its interactions with RNA polymerase II holoenzyme, ER- $\alpha$ , AR, p53, c-MYC and transcriptional co-activators p300/CBP and a co-repressor CtIP (Scully et al. 1997a, Anderson et al. 1998, Wang et al. 1998, Zhang et al. 1998a, Fan et al. 1999, Li et al. 1999, Pao et al. 2000, Park et al. 2000, Fan et al. 2001a, Zheng et al. 2001). BRCA1 interacts also with mismatch repair proteins MSH2 and MSH6 (Wang et al. 2000b) involved in transcription-coupled DNA repair, which has been reported to be defective in cells lacking functional BRCA1 (Gowen et al. 1998). BRCA1-BARD1 complex, like other RING proteins, functions as a ubiquitin ligase (Hashizume et al. 2001), the specificity of

## REVIEW OF THE LITERATURE

which is currently unknown. BARD1-BRCA1 complex also interacts with polyadenylation factor CstF-50 (Kleiman and Manley 1999) and with a de-ubiquitinating enzyme BAP1 (Jensen et al. 1998) suggesting that BRCA1 acts in RNA polyadenylation and in ubiquitin-dependent protein degradation. Thus, by regulating the degradation and activity of target mRNA or proteins, the BRCA1/BARD1 complex may possess important functions in regard to tumor suppression (reviewed in Venkitaraman 2002). Recently, BRCA1 has been shown to co-localize with XIST mRNA suggesting a role in female X chromosome inactivation (Ganesan et al. 2002). The putative roles of BRCA1 are summarized in Figure 4.

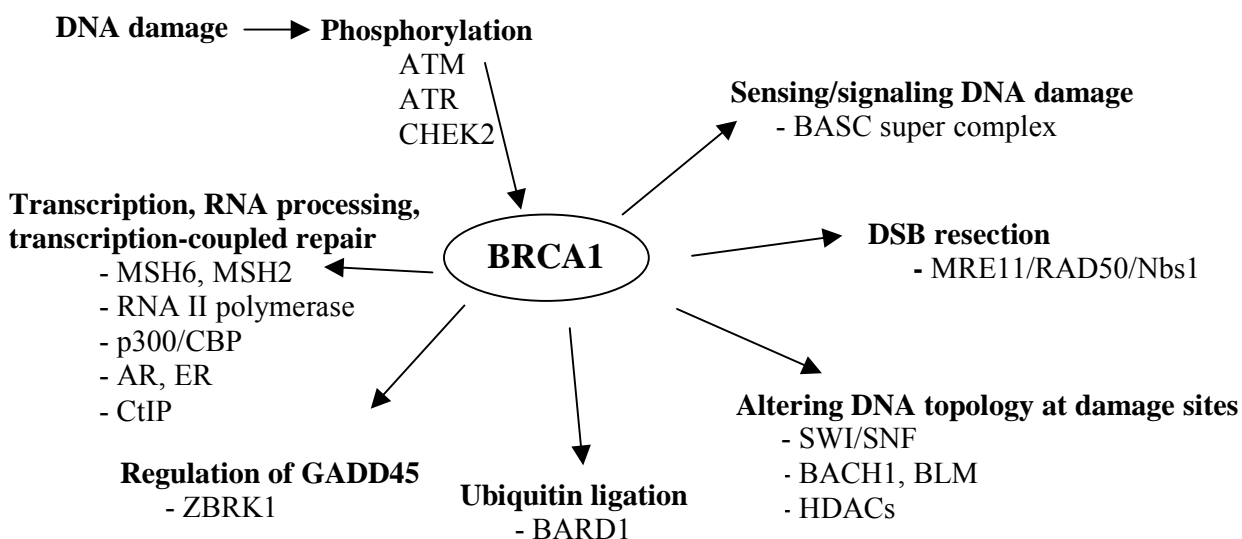

**Figure 4.** Putative roles of BRCA1 in multiple cellular pathways in response to DNA damage through its interactions with different proteins or protein complexes. Modified from Venkitaraman 2002. (DSB = double strand break; BASC = BRCA1-associated genome surveillance complex; CtIP = C-terminal interacting protein; AR = androgen receptor; ER = estrogen receptor; CBP = CREB binding protein; MSH6 and MSH2 = MutS homolog 6 and 2, mismatch repair proteins; ATM = ataxia-telangiectasia mutated; ATR = AT mutated and Rad3 related; CHEK2 = Checkpoint homolog (*S. pombe*); BLM = Bloom helicase; BACH1 = member of the DEAH family of DNA helicases; ZBRK1 = Zinc finger and BRCA1-interacting protein with a KRAB domain 1, transcription factor; BARD1 = BRCA1-associated RING domain 1; SWI/SNF = chromatin remodeling complex; HDAC = histone deacetylase; MRE11/RAD50/Nbs1 = homologs of yeast proteins involved in homologous recombination)

### **3.3.2. BRCA2**

BRCA2 binds directly RAD51, a eukaryotic homolog of bacterial RecA essential for DSB repair by HR (Sharan et al. 1997, Wong et al. 1997). RAD51 function is essential for the DNA/DNA interactions that lead to strand invasion and exchange between the sister

chromatids in HR (Baumann and West 1998). RAD51 interacts with BRCA2 by binding to BRC repeats located in exon 11 of BRCA2 (Wong et al. 1997, Chen et al. 1998c). The BRCA2-RAD51 interaction involves a substantial proportion of the cellular pool of both proteins. BRCA1 has also been reported to co-localize with RAD51 and BRCA2 but only a small proportion of cellular BRCA1 is found in this complex (Scully et al. 1997c, Chen et al. 1999, Wang et al. 2000b). This suggests distinct roles for BRCA1 and BRCA2 in DNA damage response. In cellular response to DNA damage, RAD51 and BRCA2 co-localize to damage-induced foci, which represent the sites of DSBs (Scully et al. 1997c). *In vitro* studies have shown that BRC3 and BRC4 repeats of BRCA2 block the ability of RAD51 to form nucleoprotein filaments prior to strand invasion (Davies et al. 2001). Thus, it has been suggested that BRCA2/RAD51 interaction controls the binding of RAD51 to damaged DNA and not to undamaged DNA and prevents the inappropriate activation of DNA recombination during normal DNA metabolism (reviewed in Liu and West 2002, and Venkitaraman 2002).

BRCA2 is also suggested to take part in transcriptional regulation. The product of exon 3 of BRCA2, when fused to the Lex A DNA-binding domain, activates transcription in yeast (Milner et al. 1997). Germ-line deletion of exon 3 occurs in a Swedish family with predisposition to breast and ovarian cancer indicating that transcriptional activity of BRCA2 may be important in tumor suppression (Nordling et al. 1998). BRCA2 interacts with the transcriptional co-activator protein P/CAF, which has also histone acetylase activity (Fuks et al. 1998). Recently, transactivation domain of BRCA2 was reported to interact with replication protein A (RPA), which is essential for DNA repair, replication and recombination suggesting a possible link between BRCA2 transactivation domain and replication or DNA repair rather than transcription (Wong et al. 2003).

BRCA2 has also been implicated in cell cycle control. BRCA2 interacts with and its C-terminus is phosphorylated *in vitro* by a mitotic checkpoint protein, hBURB1 (Futamura et al. 2000). The transactivation domain of BRCA2 has also been reported to possess a binding site for a kinase (Milner et al. 2000). However, it is not known how phosphorylation of BRCA2 affects its function (Figure 5). BRCA2-deficient cells have been shown to have preserved checkpoint functions (Patel et al. 1998), and BRCA2 probably participates in control of G2/M checkpoint by interacting with a novel protein, BRAF35 (Marmorstein et al. 2001) (Figure 5). BRCA2-BRAF35 complex associates with condensed chromatin and microinjection of antibodies against either protein results in G2 cell cycle delay (Marmorstein et al. 2001). In addition, indirect evidence of involvement of BRCA2 in mitotic control is provided from studies of cells lacking functional BRCA2 and

showing centrosome amplification (Tutt et al. 1999). The suggested functions of BRCA2 are shown in Figure 5.

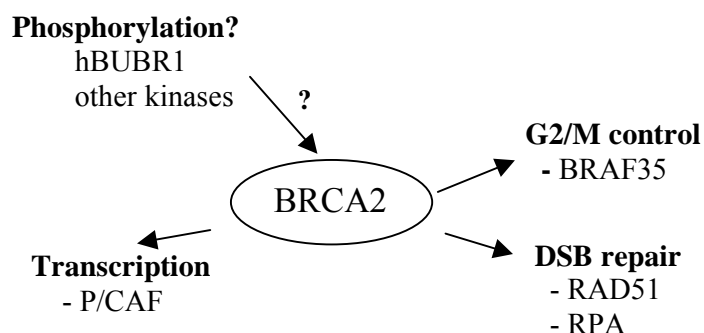

**Figure 5.** Putative roles of BRCA2 in various cellular pathways through its protein interactions. Modified from Venkitaraman 2002. (DBS = double strand break, hBUBR1 = mitotic checkpoint protein, BRAF35 = BRCA2-associated factor, a structural DNA-binding protein, P/CAF = transcriptional co-activator protein, RAD51 = homolog of bacterial RecA involved in homologous recombination, RPA = replication protein A)

### 3.4. Tissue-specificity of cancer predisposition

*BRCA1/2* genes are expressed in various tissues and take part in fundamental and universal cellular processes such as DNA damage response. Nevertheless, germ-line mutations predispose to certain epithelial cancers, such as breast, ovarian or prostate cancer, and the underlying mechanism for this tissue-specificity remains poorly understood. A few hypotheses have been proposed on the tissue-restricted tumor phenotype regarding the *BRCA1* gene emphasizing the role of estrogen (reviewed in Hilakivi-Clarke 2000). According to one hypothesis, the link between *BRCA1* mutations and breast (and ovarian) cancer could be provided from the role of BRCA1 in transcription-coupled repair of oxidative DNA damage and estrogen having specific oxidative metabolites that have been reported to be genotoxic to cells (Gowen et al. 1998, Liehr 2000). Another model emphasizes the role of BRCA1 in the modulation of estrogen signaling pathways and thus, the expression of hormone-responsive genes as a possible explanation to tissue-specificity of BRCA1 inactivation (reviewed in Hilakivi-Clarke 2000, and Venkitaraman 2002). In fact, several studies have shown that BRCA1 inhibits estrogen-dependent (Fan et al. 1999, Fan et al. 2001a) and ligand-independent (Zheng et al. 2001) transactivation by the estrogen receptor through its direct interaction with ER- $\alpha$ . BRCA1 has also been reported to enhance androgen-dependent transactivation by the AR (Park et al. 2000, Yeh et al. 2000) and allelic variants of AR have been shown to modify cancer risk in *BRCA1* mutation carriers



(Rebbeck et al. 1999). The role of BRCA1 in nuclear hormone signaling pathways could be important in the context of tissue-specificity, but does not, however, directly incorporate its function in DSB repair, lack of which is typical for BRCA1-deficient cells. In addition, the question regarding the tissue-specific tumor phenotype associated with *BRCA2* mutations remains unanswered.

### **3.5. Hereditary breast cancers associated with *BRCA1* and *BRCA2* mutations**

Breast tumors in *BRCA1* and *BRCA2* mutation carriers manifest earlier in life than in unselected control patients without family history (Easton et al. 1994). Many studies have also shown that particularly *BRCA1*-associated hereditary breast cancers (BRCA1-HBCs) differ in relation to tumor characteristics from control tumors occurring in the absence of germ-line mutations.

BRCA1-HBCs are more frequently of histological grade three (Marcus et al. 1996, Johannsson et al. 1997, Karp et al. 1997, Lakhani et al. 1998, Robson et al. 1998, Noguchi et al. 1999) and negative for both estrogen and progesterone receptor (ER and PgR) expression than control breast tumors (Johannsson et al. 1997, Karp et al. 1997, Ansquer et al. 1998, Loman et al. 1998, Lynch et al. 1998, Verhoog et al. 1998). BRCA1-HBCs have been reported to be more often aneuploid and of medullary subtype, and to show higher mitotic count and stronger lymphocyte infiltration compared to control tumors (Marcus et al. 1996, Johannsson et al. 1997, Eisinger et al. 1998). Lack of functional TP53 protein due to *p53* gene mutations and absence of ERBB2 amplification are also specific features of BRCA1-HBCs (Johannsson et al. 1997, Eisinger et al. 1998, Lynch et al. 1998, Armes et al. 1999, Noguchi et al. 1999, Grushko et al. 2002). BRCA1-HBCs show also high levels of MYB oncogene compared to BRCA2-HBCs or sporadic breast cancers (Kauraniemi et al. 2000). Some phenotypic features (inactivation of *p53*, hormone receptor negativity, high grade) of BRCA1-HBCs could indicate a poor outcome but studies addressing survival of breast cancer patients in BRCA1 families are controversial to this. Thus, there seems to be an independent effect of *BRCA1* mutations on disease outcome, which has remained somewhat unclear (Foulkes et al. 1997, Johannsson et al. 1998a, Johannsson et al. 1998b, Chappuis et al. 1999, Hamann and Sinn 2000, Eerola et al. 2001b).

*BRCA2*-associated hereditary breast cancers (BRCA2-HBCs) have not consistently revealed a specific pattern of tumor characteristics, which may reflect the heterogeneous pathogenesis of *BRCA2*-induced breast cancer. Some reports have shown that BRCA2-HBCs are of high histological grade (Agnarsson et al. 1998, Lakhani et al. 1998, Lynch et

## REVIEW OF THE LITERATURE

al. 1998) while one study showed an association with lower grade (Marcus et al. 1997). The hormone receptor status has been reported to be similar in BRCA2-HBCs and control tumors (Loman et al. 1998, Lynch et al. 1998, Verhoog et al. 1999), but an excess of receptor-positive tumors has also been described (Agnarsson et al. 1998). Studies addressing the histological subtype of the BRCA2-HBCs have also been controversial (Marcus et al. 1997, Agnarsson et al. 1998), but less tubule formation has been reported (Agnarsson et al. 1998, Lakhani et al. 1998). In contrast to BRCA1-HBCs, *p53* gene is not more frequently inactivated in BRCA2-HBCs than control tumors (Crook et al. 1998, Gretarsdottir et al. 1998), and reports regarding the ERBB2 gene status have shown similar results (Noguchi et al. 1999). The prognosis of patients with BRCA2-HBC has equally been discordant between studies reporting either worse, equal or even better outcome when compared to control breast cancer patients (Lee et al. 1999a, Loman et al. 2000, Eerola et al. 2001b). These conflicting results can be partly due to relatively small numbers of study subjects and their different ethnic backgrounds or different criteria for positive family history or for control groups. Specific characteristics of BRCA1/2-HBCs are presented in Table 3.

**Table 3.** Specific features of BRCA1/2-HBCs compared to control tumors.

BRCA1-HBCs	BRCA2-HBCs
Early-onset	Early-onset
High grade	Moderate/high grade
Medullary subtype	ER/PgR positive
ER/PgR negative	Decreased tubule formation
High mitotic count	
Aneuploidy	
Lymphocyte infiltration	
p53 inactivation	
ERBB2-negative	
MYB amplification	

Of the two CGH studies published, one revealed an excess number of overall genetic changes in BRCA1/2 breast tumors compared to sporadic breast tumors (Tirkkonen et al. 1997b). In addition, some chromosome arms of BRCA1/2 breast tumors showed distinct genetic alteration patterns (Tirkkonen et al. 1997b). The other study showed a specific CGH profile for *BRCA1*-mutation tumors (Wessels et al. 2002). A detailed LOH analysis showed specific patterns of chromosomal aberrations in breast tumors associated with a specific *BRCA2*-mutation (Ingvarsson et al. 1998). Recently, gene expression profiling by cDNA

microarray has been used to distinguish between BRCA1/2-HBCs and sporadic breast cancers (Hedenfalk 2002). Different sets of genes were expressed in these three groups suggesting functional differences between the tumor types. The excess of overall genetic changes in BRCA1/2-deficient tumors versus control tumors (Tirkkonen et al. 1997b) can be interpreted as a reflection of the proposed caretaker role of *BRCA1/2* genes in maintenance of genomic integrity. However, inactivation of caretaker *BRCA1* gene and the possibly resulting genomic instability might alternatively predict highly variable tumor phenotypes rather than distinct tumor characteristics associated with BRCA1 breast tumors.

#### **4. BRCA1 and BRCA2 in sporadic breast cancer**

Somatic *BRCA1* and *BRCA2* mutations are practically absent in sporadic breast cancers (Futreal et al. 1994, Lancaster et al. 1996, Miki et al. 1996, Teng et al. 1996), a rather unexpected finding since some other TS genes, such as *RBI* and *APC*, have been shown to be involved in both hereditary and sporadic forms of cancer (reviewed in Stahl et al. 1994, and Fodde 2002). However, evidence of involvement of the *BRCA1/2* genes in sporadic cancer development has been reported.

##### **4.1. Expression of BRCA1 and BRCA2**

Decrease in BRCA1 mRNA has been observed in invasive tumors as compared to normal cells or carcinoma in situ (Thompson et al. 1995, Kainu et al. 1996, Magdinier et al. 1998, Ozelik et al. 1998, Sourvinos and Spandidos 1998), and experimental antisense inhibition of BRCA1 accelerated growth of tumors (Thompson et al. 1995). Decreased levels of BRCA1 protein have also been shown in sporadic breast cancers by several immunohistochemical studies (Taylor et al. 1998, Wilson et al. 1999, Yoshikawa et al. 1999, Yang et al. 2001). High-grade tumors were reported to have the lowest levels of BRCA1 protein but surprisingly, both normal cells and invasive lobular and low-grade breast tumor cells showed similar levels of BRCA1 immunostaining (Wilson et al. 1999). Low levels of BRCA1 protein have been associated with markers of an aggressive tumor phenotype, ERBB2 overexpression and poor prognosis (Lee et al. 1999b, Seery et al. 1999, Yoshikawa et al. 1999).

Studies on BRCA2 expression in sporadic breast cancers are quite unexpected if BRCA2 is considered to act as a classical TS. Many studies have shown that BRCA2 mRNA levels are higher in breast tumor cells compared to normal cells (Egawa et al. 2001a, Egawa et al. 2002), even if one study revealed both down- and up-regulation of BRCA2 mRNA in

## REVIEW OF THE LITERATURE

tumors (Bieche et al. 1999). However, reconstituted expression of wild-type BRCA2 in pancreatic BRCA2-null cell line (Capan-1) inhibited cell proliferation in culture and suppressed tumor growth in animals (Wang et al. 2002) indicating that situation *in vivo* may be more complex. High BRCA2 mRNA levels have been shown to associate with high-grade tumors, and to predict poor prognosis, while low levels of BRCA2 mRNA associated with favorable response to docetaxel treatment (Bieche et al. 1999, Egawa et al. 2001a, Egawa et al. 2001b, Egawa et al. 2002).

### **4.2. LOH at *BRCA1* and *BRCA2***

Genetic aberrations at *BRCA1/2* regions have been frequently reported and might be responsible for the changes in BRCA1/2 expression detected in breast tumors. LOH at *BRCA1* has been reported to occur in 20-50% of sporadic breast cancer tumors and has been associated with characteristics of an aggressive tumor phenotype (Beckmann et al. 1996, Niederacher et al. 1997, Schmutzler et al. 1997, Tseng et al. 1997, Phelan et al. 1998, Rio et al. 1998, Gonzalez et al. 1999, Silva et al. 1999, Hanby et al. 2000). LOH at *BRCA2* is also common, occurring in 20-40% of breast cancer tumors but is not consistently associated with markers of an aggressive tumor phenotype (Beckmann et al. 1996, van den Berg et al. 1996, Bieche et al. 1997, Schmutzler et al. 1997, Tseng et al. 1997, Rio et al. 1998, Katsama et al. 2000). Studies associating LOH at *BRCA1/2* loci and survival have been discrepant (van den Berg et al. 1996, Bieche et al. 1997, Gentile et al. 1999, Querzoli et al. 2001). Some studies have suggested that breast tumors with combined LOH at both *BRCA1/2* loci specifically associate with markers of poor prognosis (Kelsell et al. 1996, Silva et al. 1999). Studies using conventional RT-PCR have shown an association between LOH at *BRCA1* and variation in BRCA1 expression levels in breast tumors (Ozcelik et al. 1998, Sourvinos and Spandidos 1998), but immunohistochemical studies have failed to show this association (Bernard-Gallon et al. 1999, Rio et al. 1999). LOH at *BRCA2* has not been reported to associate with either BRCA2 mRNA or protein levels in breast cancer tumors, indicating other mechanisms of regulation (Bieche et al. 1999, Bernard-Gallon et al. 2000).

### **4.3. Promoter hypermethylation**

Epigenetic mechanisms, such as hypermethylation of CpG islands of gene promoter regions, have been proposed as a mechanism of TS gene inactivation in tumor cells (reviewed in Esteller 2002). In fact, 10-30% of breast cancer tumors show BRCA1 promoter hypermethylation, which associates with decreased levels of BRCA1 mRNA

(Catteau et al. 1999, Esteller et al. 2000, Niwa et al. 2000, Rice et al. 2000) but this clearly is not the sole mechanism for BRCA1 down-regulation in sporadic breast cancers. A significant association was not found between LOH at *BRCA1* and methylation suggesting that in the absence of somatic mutations both methylation and LOH are considered as first ‘hits’ and not complementing ‘hits’ according to TS gene theory (Knudson 1971, Esteller et al. 2000). However, association between BRCA1 promoter hypermethylation, lack of estrogen receptor expression and medullary tumor subtype suggests a possible link between sporadic breast tumors with BRCA1 promoter hypermethylation and BRCA1-HBCs (Catteau et al. 1999, Esteller et al. 2000, Niwa et al. 2000). In fact, gene expression profiling of hereditary and sporadic breast cancers mis-classified a sporadic breast tumor as BRCA1-HBC but a detailed analysis of that sporadic tumor showed promoter hypermethylation of BRCA1 (Hedenfalk et al. 2001). BRCA2 promoter region does not seem to undergo hypermethylation in breast tumors (Collins et al. 1997). Despite the absence of *BRCA1/2* mutations, the *BRCA1/2* genes probably have a role in sporadic breast cancer pathology due to alterations in their expression status. Nevertheless, the mechanisms involved in the somatic inactivation and regulation of expression of the *BRCA1/2* genes still remain partly unexplained. The general features of *BRCA1/2* genes and their possible alterations in sporadic breast cancer are summarized in Table 4.

**Table 4.** Characteristics of BRCA1 and BRCA2 in sporadic breast cancer.

BRCA1	BRCA2
No somatic mutations	No somatic mutations
LOH in 20-50% of tumors associating with an aggressive phenotype	LOH in 20-40% of tumors
Decreased levels of BRCA1 mRNA and protein	High levels of BRCA2 mRNA
Promoter hypermethylation in 10-30% of tumors	

## **Aims of the study**

1. To study the somatic genetic re-arrangements of the *BRCA1* and *BRCA2* genes in hereditary and sporadic breast cancer tumors (I, II)
2. To study the changes in *BRCA1* gene expression and its relation to somatic genetic re-arrangements and promoter hypermethylation in sporadic breast cancer tumors (III)
3. To establish and characterize a new experimental model and cell line for future purposes of studying *BRCA1* gene function and therapeutical aspects of BRCA1 breast cancers (IV)

## Materials and methods

### 1. Tumor material

All primary breast tumor samples were snap-frozen after surgical excision and stored at –70°C until processed in further analyses.

#### 1.1. Hereditary breast tumors

For studies I and II, seventeen primary breast cancers from germ-line *BRCA1* mutation carriers (sixteen tumors with an identified mutation and one with strong linkage) and eight primary breast cancers from germ-line *BRCA2* mutation carriers were derived from the Department of Oncology, University of Lund. *BRCA1/2* mutations have been determined by protein truncation test and direct sequencing as previously described (Table 5) (Johannsson et al. 1996, Hakansson et al. 1997). Blood samples from fifteen germ-line *BRCA1* mutation carriers and five germ-line *BRCA2* mutation carriers were used as a source of constitutive leukocyte DNA. One *BRCA2* patient had two primary tumors (two cases with germ-line mutation 2024del5, see Table 5), of which both were analyzed. Leukocyte DNA from a relative to one *BRCA1* and one *BRCA2* mutation carrier was used to distinguish mutant and wild-type alleles.

For study IV, tumor tissue was derived from a patient belonging to a Swedish family previously described to carry a *BRCA1* germ-line mutation (Johannsson et al. 1996). Both breast and ovarian cancers were found among the family members. At the age of 46, this patient was diagnosed and surgically treated for a stage I ductal invasive breast cancer followed by local radiotherapy but no chemo- or hormonal therapy. She developed a contralateral primary breast cancer with axillary lymph node metastases (T1N1M0) at the age of 53 and underwent two operations, a primary segmental resection and a subsequent axillary dissection. Tumor tissue obtained during the axillary dissection was used to establish primary xenograft growths in mice.

The presence of patient's *BRCA1* germ-line mutation 1806C→T was known prior to her second operation (Johannsson et al. 1996). The mutation was discovered by the presence of an aberrantly short band upon protein truncation test of exon 11 of the *BRCA1* gene, and verified by direct sequencing as described before (Johannsson et al. 1996).

**Table 5.** *BRCA1* and *BRCA2* germ-line mutations.

	<b>Result of the mutation</b>	<b>Location of the mutation</b>	<b>Number of samples</b>
<b>BRCA1</b>			
300T→G	Cys61Gly	Exon 6, RING domain	1
1177G→A	Trp353Stop	Exon 11	1
1201del11	Ser361Stop	Exon 11	1
1806C→T	Gln563Stop	Exon 11	4
2594delC	Ile845Stop	Exon 11	3
3172ins5	Thr1025Stop	Exon 11	3
3829delT	Leu1263Stop	Exon 11	1
4808C→G	Glu1115Stop	Exon 16	1
5328insC	Glu1829Stop	Exon 20, BRCT domain	1
<b>BRCA2</b>			
2024del5	Ser599Stop	Exon 10	2
3058A→T	Lys944Stop	Exon 11	2
4486delG	Val1447Stop	Exon 11, BRC repeats	1
5445del5	Tyr1739Stop	Exon 11, BRC repeats	1
6293C→G	Ser2022Stop	Exon 11, BRC repeats	2

## 1.2. Sporadic breast tumors

For study I, twenty-one primary sporadic breast cancers, previously analyzed for AI at either *BRCA1* or *BRCA2* locus (Borg et al. 1994, van den Berg et al. 1996), were obtained from the Department of Oncology, University of Lund. For study II, fourteen primary sporadic breast cancer tumors were derived from the Tampere University Hospital. For study III, tumor specimens from sixty primary sporadic breast carcinomas were obtained from the Tampere University Hospital and Tampere City Hospital. The mean age at diagnosis of these breast cancer patients was 62 years and the median age was 65 years. All but two of the tumors were invasive ductal carcinomas. Seventeen percent of the invasive ductal carcinomas were grade one, 45% were grade two and 38% were grade three. None of the breast cancer patients in studies I, II and III had strong familial history for breast and ovarian cancer, and therefore they are not likely to be carriers of germ-line *BRCA1/2* mutations.



### **1.3. Breast cancer cell line**

For studies III and IV, breast cancer cell line HBL-100 was obtained from the American Type Culture Collection (ATCC) and was cultured according to the recommended conditions. The HBL-100 cell line was used in the preparation of the standard curve for the real-time semi-quantitative RT-PCR analyses in study III, and as a control cell line in the analyses of BRCA1 mRNA and protein expression levels in study IV.

## **2. Methods**

### **2.1. Fluorescence in situ hybridization (FISH)(I-IV)**

#### **2.1.1. Probes**

By screening the genomic PAC library (Ioannou et al. 1994) with primers specific for the *BRCA1* and *BRCA2* genes, one clone was identified for both genes (PAC 103014 and PAC 92M18, respectively). The specificity of these clones was confirmed by additional PCR analyses by amplifying various exons and using probe DNA as template. The PAC 103014 contained the entire *BRCA1* gene and the PAC 92M18 included the 3'-end of the *BRCA2* gene (exons 25-27). The PAC 103014 probe mapped to 17q21 and the PAC 92M18 probe to 13q12-q13 by FISH. The fractional length from p-telomere (Flpter) (Stokke et al. 1995) was 0.560 ( $\pm 0.026$ , SD) for the BRCA1 probe and 0.302 ( $\pm 0.049$ , SD) for BRCA2. Chromosome 17 centromere probe (p17H8) was used as a copy number reference for *BRCA1*. For *BRCA2*, a PAC probe specific for the *ETB* gene (at 13q22) was used as reference, because a specific centromere probe for chromosome 13 is not available. Flow-cytometric DNA index was determined as previously described (Tanner et al. 1998) and used as an additional copy number reference to *BRCA2* in order to detect large deletions at 13q, which cover both *BRCA2* and *ETB* (I, II). The hybridization efficiency of the *BRCA1* and *BRCA2* probes was tested on a non-malignant breast sample. The average copy numbers for *BRCA1*, *BRCA2*, *ETB* and chromosome 17 centromere were 1.94 ( $\pm 0.043$ , SEM), 1.96 ( $\pm 0.048$ , SEM), 2.00 ( $\pm 0.028$ , SEM), and 1.92 ( $\pm 0.046$ , SEM), indicating high hybridization efficiency.

In study III, sporadic breast tumors were also studied for the *ERBB2* oncogene amplification using commercially available *ERBB2* probe (Tanner et al. 2001), and in study IV, *p53* gene copy number was analyzed using gene-specific probe and chromosome 17 centromere probe as reference.

### **2.1.2. Hybridization**

In studies I, II and IV, imprint touch preparations were done by lightly pressing semi-thawed frozen tumor pieces onto Superfrost Plus microscope slides (Menzel, Germany). Slides were fixed in 50%, 70% and twice 100% Carnoy's solution (3:1 methanol/acetic acid, 10 to 15 minutes each) and air-dried. Gene-specific probes were labeled with digoxigenin-11-dUTP (Boehringer Mannheim, Indianapolis, IN) or biotin-14-dATP (Gibco BRL) and centromere probes with FITC-dUTP (DuPont, Boston, MA) using nick translation. Two-color FISH was performed as previously described (Tanner et al. 1998). Slides were denatured in 70% formamide/2× SSC at 70°C to 72°C for 2 to 3 minutes and dehydrated in graded ethanol series. Twenty µl of the hybridization mixture, consisting of 50 ng of labeled appropriate gene-specific probe, 15 ng of labeled appropriate pericentromeric probe and 1 µg of unlabeled Cot-1 DNA (Life Technologies, Inc., Gaithersburg, MD) in 50% formamide/10% dextran sulfate/2× SSC, was denatured for 5 minutes at 72°C and applied onto slides. In study III, freshly frozen tumor tissue sections were fixed with 6:3:1 ethanol, chloroform and acetic acid, and then air-dried. Ten µl of the hybridization mixture containing 50 ng of *BRCA1* and 15 ng of chromosome 17 centromere specific probes, human placental DNA and Cot-1 DNA (Roche Biochemicals) was applied onto slides that were coverslipped, sealed and denatured at 94-95°C for 3 minutes on a thermal plate. Hybridization was performed overnight at 37°C under a coverslip in a moist chamber. After hybridization, the bound probes were detected immunohistochemically with avidin-FITC (Vector Laboratories, Burlingame, CA) and anti-digoxigenin rhodamine (Boehringer Mannheim). Samples were counterstained with 0,1 µM 4,6-diamino-2-phenylindole (DAPI) in an antifade solution (Vectashield, Vector Laboratories).

### **1.1.3. Fluorescence microscopy**

Hybridization signals were scored using a Zeiss Axioplan 2 epifluorescence microscope equipped with dual band-pass fluorescence filter (Chromatechnology, Battleboro, NV), which enables simultaneous detection of both fluorescein and Texas red fluorescence. Hybridization signals from 50-100 nuclei were scored to assess the copy number status of the *BRCA1* and *BRCA2* genes. Deletion of the *BRCA1/2* genes was defined if the average ratio of *BRCA1* or *BRCA2* signals relative to chromosome 17 centromere signals or *ETB* signals, respectively, was 0.80 or less. Gain was defined if the ratio was 1.30 or more. The loss of entire 13q was defined if the average ratio of *BRCA2* and *ETB* signals relative to tumor ploidy (= DNA index x 2) were 0.80 or less. In the definition of these limits a non-cancerous cell contamination was taken into consideration because signals were scored unselectively in order to avoid any bias. Digital images were taken with a Hamamatsu 9585

camera (Hamamatsu, Hamamatsu City, Japan) operated via ISIS image analysis software (MetaSystems, Altlussheim, Germany). The ISIS imaging system allows multiple focal planes to be projected on the final image thereby allowing visualization of all FISH signals in the nucleus.

## **2.2. Allelic imbalance by microsatellite analysis (I, II)**

PCR followed by capillary electrophoresis was used to detect allelic imbalance at polymorphic microsatellite markers by comparing the allelic pattern of tumor and blood-derived DNA in hereditary breast tumors. DNA was extracted using the Wizard Genomic DNA purification kit (Promega, Madison, WI) according to the manufacturer's recommendations. Two *BRCA1* intragenic markers (D17S855 and D17S1322) (Albertsen et al. 1994) and two markers physically linked to *BRCA2* (D13S260 and D13S267) (Wooster et al. 1994) were analyzed using primers with published sequence (Gyapay et al. 1994) (Research Genetics, Huntsville, AL, USA). Twenty-one sporadic breast tumors (study I) have been examined previously for AI either at *BRCA1* (markers THRA1, D17S855, D17S579) (Borg et al. 1994), or at *BRCA2* (markers D13S260, D13S267, D13S290, D13S219) (van den Berg et al. 1996).

The PCR mixture (20 $\mu$ l) contained 10mM Tris-HCl (pH 8.3), 50mM potassium chloride, 1.0-2,5mM magnesium chloride, 0.13 $\mu$ M of each primer, 20 $\mu$ M of dNTPs, 0.75 units of Dynazyme Taq polymerase (Finnzymes, Helsinki, Finland) and 80 ng of genomic DNA. The forward primer has been labeled fluorescently either with TET (green) or HEX (yellow) dye (Perkin Elmer). The PCR was carried out in an Omnigene thermocycler (Hybaid) and consisted of 4 min at 94°C, followed by 30-32 cycles of 30-45 sec at 93°C, 30-45 sec at 50-60°C, 45 sec at 72°C, followed by one cycle at 72°C. All the PCR reactions were repeated twice. An aliquot (0.7-1.0  $\mu$ l) of the PCR product was added to 12  $\mu$ l formamide and 0.7  $\mu$ l TAMRA 500 size standard (Perkin Elmer) and denatured 2 min at 90°C. Capillary electrophoresis was performed using ABI PRISM™310 Genetic Analyzer according to manufacturer's instructions (Perkin Elmer). The data were collected automatically and analyzed by the GeneScan 2.1 Software. For the informative heterozygous markers, the allelic imbalance was determined by calculating the ratio of the alleles (L) as follows:  $L = (\text{Peak area}_{\text{larger tumor allele}} \times \text{Peak area}_{\text{smaller normal allele}}) / (\text{Peak area}_{\text{smaller tumor allele}} \times \text{Peak area}_{\text{larger normal allele}})$ . If  $L < 0.75$  or  $L > 1.33$ , then one of the alleles has decreased more than 25% resulting in allelic imbalance (AI), as previously defined (Kerangueven et al. 1997).

### **2.3. DNA methylation (III)**

DNA methylation in the CpG islands of the *BRCA1* promoter region in sporadic breast tumors was determined by methylation-specific PCR (MSP) (Herman et al. 1996). In brief, unmethylated cytosines, but not methylated cytosines, are chemically modified to uracils with bisulfite treatment of DNA. Primers specific either for unmethylated or methylated DNA are then used to distinguish between hypo- and hypermethylation, respectively. DNA was extracted from tumor samples using QIAGEN QIAamp Mini Kit (QIAGEN, Hilden, Germany) according to the manufacturer's recommendations. Primer sequences have been described previously (Esteller et al. 2000). The primer sequences specific for unmethylated DNA were 5'-TTGGTTTTGTGGTAATGGAAAAGTGT-3' (sense) and 5'-CAAAAATCTCAACAACTCACACCA-3' (antisense) and for methylated DNA were 5'-TCGTGGTAACGGAAAAGCGC-3' (sense) and 5'-AAATC CAACGAACTCACGCCG-3' (antisense). Primers specific for unmethylated DNA amplified a PCR product of 86 bp and primers specific for methylated DNA amplified a PCR product of 75 bp. Universally methylated human male DNA (Intergen Company, USA) was used as a positive control for the methylated alleles of the *BRCA1* gene and DNA from normal lymphocytes was used as a negative control for methylation. Bisulfite modification of DNA was performed using CpG Genome Modification Kit (Intergen Company, USA) according to the manufacturer's instructions. The PCR conditions consisted of 5 minutes of initial denaturation at 95°C, 35 cycles of denaturation at 95°C for 30 sec, annealing for 30 sec at 62°C (PCR reaction with primers specific for unmethylated DNA), 40 sec at 65°C (PCR reaction with primers specific for methylated DNA) and elongation at 72°C for 30-45 sec. Ten microlitres of each PCR reaction was loaded onto NuSieve GTG 4% agarose gels (BMA, Rockland Maine, USA) and visualized under UV illumination. If primers specifically designed for methylated DNA amplified a specific PCR product, tumor sample was interpreted as containing hypermethylated alleles of *BRCA1*.

### **2.4. Preparation of the xenograft and cell line (IV)**

Two tumor fragments (each measuring 2x2 mm) were obtained from the axillary node metastasis of a breast cancer patient carrying a germ-line *BRCA1* mutation 1806C→T (Gln563Stop). The obtained tumor fragments were placed subcutaneously in immunodeficient Balb/c nude mice (nu/nu). Specimens of the axillary metastasis (approximately 1 mm in diameter) obtained from primary surgery were also placed in culture dishes, but all primary cultures failed. However, cultures using tumor tissue from the xenograft generation 6 were successful and gave rise to an immortal cell line. The

culture medium used consisted of RPMI 1640 media with 10 mM Hepes, fetal bovine serum (10%), glucose (4.5 gr/L), pyruvic acid (0.11 gr/L) and antibiotics (penicillin and streptomycin) (incubation at 37 °C in an atmosphere of 5% CO<sub>2</sub> in air). In order to test tumor formation of the cell line, approximately 2 million cells have been injected subcutaneously in nude mice.

## **2.5. Cytogenetic analyses of the xenograft and cell line (IV)**

The xenograft-derived cultured cells were harvested (trypsinized) after exposure to colcemid for 4 hours, followed by a hypotonic shock in 0.05 M KCl, and fixation in methanol/acetic acid (3:1). G-banding of chromosomes was obtained with Wright's stain. The clonality criteria and karyotype description followed the recommendations of International System for Human Genetic Nomenclature (ISCN). Spectral karyotyping (SKY) was done according to manufacturer's instructions (SKY kit, Applied Spectral Imaging, Israel). Comparative genomic hybridization (CGH) was performed as previously described (Rennstam et al. 2001). In brief, genomic DNA was isolated from the primary tumor, the xenograft generation 6 and the cell line and labeled with FITC-dUTP (DuPont, Boston, MA). Normal control DNA was labeled with Texas Red-dUTP (DuPont) using nick translation. Labeled DNAs with unlabelled Cot-1 DNA (Life Technologies, Inc., Gaithersburg, MD) were hybridized together to normal metaphase chromosomes. The hybridizations were evaluated using a digital image analysis system as previously described (Kallioniemi et al. 1994). Green to red (tumor to normal) fluorescence ratio profiles were calculated for each chromosome from p-telomere to q-telomere to determine the copy number changes.

## **2.6. Histopathological, tumor biological and mutation analyses (III, IV)**

In study III, histopathology and hormone receptor status of sporadic breast cancer tumors were determined using standard protocols (Helin et al. 1989).

In study IV, the two primary tumors from both breasts of the BRCA1-patient, as well as the xenograft, were examined using standard histopathological techniques and the WHO histopathologic classification. Immunohistochemical stainings were performed using commercially available antibodies to the estrogen receptor (ER; clone 1D5 (Dako)), progesterone receptor (PgR; clone hPRa2+hPRa3 (Neomarkers)), ERBB2 oncoprotein (clone NCL-B11 (Novocastra)), TP53 (clone DO-7 (Novocastra)), Ki67 (clone MM-1 (Novocastra)), epidermal growth factor receptor (EGFR; clone EGFR.113 (Novocastra)) and keratin 8 (5D3 (Novocastra)) (IV). DNA flow cytometry was carried out as previously

## MATERIALS AND METHODS

described (Johannsson et al. 1997) (III, IV). Direct sequencing was used to verify the mutation status of the *BRCA1* gene in xenograft and cell line (IV). Direct sequencing was also used to investigate the entire coding region of the *p53* gene in the primary tumor, xenograft and cell line (IV).

### **2.7. Expression of BRCA1 (III, IV)**

#### **2.7.1. RNA extraction and cDNA synthesis (III, IV)**

Total RNA from xenograft, control HBL-100 breast cancer cell line and primary sporadic breast cancer tumors was isolated using Sigma GenElute Mammalian Total RNA Kit (Sigma-Genosys, UK) according to the manufacturer's instructions (as an exception in study IV, see page 42). An aliquot of 3 µg total RNA was used for the first-strand cDNA synthesis with Superscript II reverse transcriptase and random hexamer primer according to the manufacturer's instructions (Invitrogen, Life Technologies, USA). Parallel cDNA synthesis reactions with no added reverse transcriptase were performed.

#### **2.7.2. Qualitative RT-PCR (IV)**

Xenograft sample was analyzed for the mRNA expression of the *BRCA1* gene. *BRCA1* has several commonly expressed splice variants (Lu et al. 1996), and the expression of all these variants as well as the full-length *BRCA1* mRNA was studied. The following primers were used for the PCR amplification of *BRCA1* cDNA in xenograft and HBL-100 cell line: 5'-ACAAAGCAGCGGATACAACC-3' (Primer 1, sense primer in exon 8), 5'-ACATGGCTCCACATGCAAG-3' (Primer 2, antisense primer in exon 11), 5'-GCAGTCTTCAGAGACGCTTG-3' (Primer 3, antisense in exon 12) and 5'-GGATGAAATCAGTTTGGATTCTG-3' (Primer 4, sense primer in exon 10). Primers 1 and 2 were designed to amplify 324 and 200 bp products corresponding to the full length and delta9,10 *BRCA1* mRNAs, respectively. Primers 1 and 3 were designed to amplify 339 and 215 bp products corresponding to the delta11b and delta9,10,11b *BRCA1* mRNAs, respectively. Primers 3 and 4 were designed to amplify a product of 199 bp, which corresponds to the delta11b *BRCA1* mRNA (Figure 6). The primers used were modified from the previously described primers designed to amplify the full length *BRCA1* and its common splice variants (Orban and Olah 2001).

The PCR mixture (25 µl) contained 0.3 µg of cDNA template, 10 mM Tris-HCl (pH 8.8 at 25°C), 1.5 mM MgCl<sub>2</sub>, 50 mM KCl and 0.1 % Triton<sup>®</sup> X-100, 0.2 mM of dNTPs, 0.1 µM

of sense and antisense primer and 2 units of Dynazyme Taq polymerase (Finnzymes, Helsinki, Finland). The PCR reactions were carried out in PTC-100 Programmable Thermal Controller (Peltier-Effect Cycling, MJ Research, Inc.). The PCR reaction consisted of 3 min at 95°C, followed by 29 cycles of 1 min at 94°C, 40 sec at 56°C, 1 min at 72°C and finally followed by one cycle for 5 min at 72°C. The PCR products were analyzed on 1.5% agarose gels.

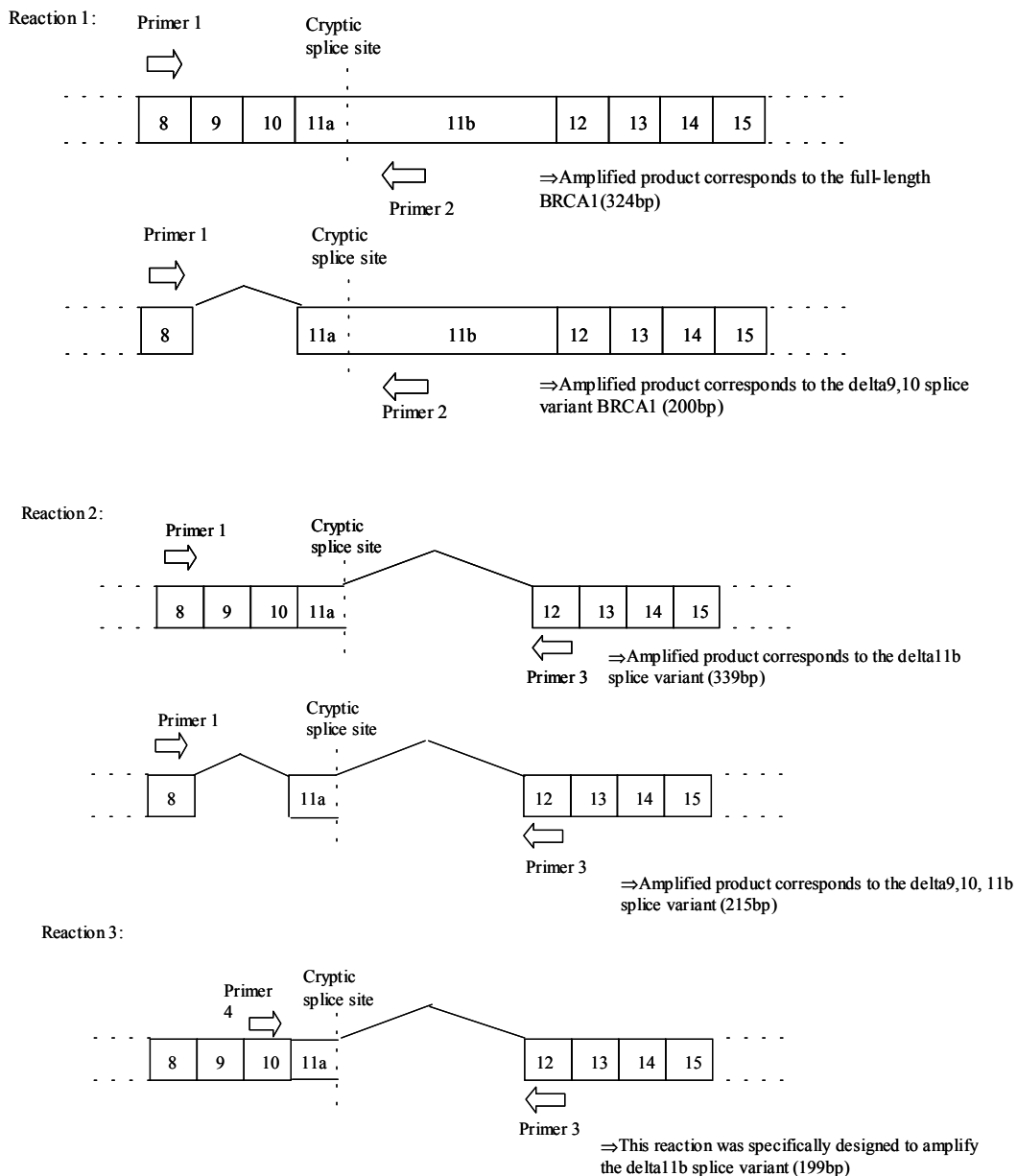

**Figure 6.** Schematic presentation of the BRCA1 cDNA primers and reactions designed to amplify full-length BRCA1 and its common splice variants (IV).

### 2.7.3. Quantitative real-time RT-PCR (III)

Expression levels of BRCA1 mRNA were studied in primary sporadic breast cancers. One of the common splice variants of BRCA1 is BRCA1-delta11b, which lacks most of the large central exon 11 and thus nuclear localization sequences and many protein-protein interaction sites (Lu et al. 1996, Wilson et al. 1997). The expression levels of both forms were studied in sporadic breast cancers and thus, primers were designed for both full-length BRCA1 (mRNA with intact exon 11) and BRCA1-delta11b splice variant. In order to avoid amplification of genomic DNA, primers were designed to amplify several exons or to cover exon-exon boundaries. Samples of the first strand cDNA synthesis without adding reverse transcriptase and samples with no template were used as negative PCR controls. In order to prepare the standard curve for the real-time RT-PCR analyses, RNA from the breast cancer cell line HBL-100 was extracted, reverse-transcribed and used in serial dilutions corresponding to the cDNA transcribed from 750, 150, 30, 6 and 1,2 ng of the total RNA.

Since the expression of *BRCA1* gene is known to be cell cycle dependent (Chen et al. 1996), we used the similarly cell cycle dependent Cyclin B1 mRNA (Hwang et al. 1995) to adjust for the variation in the tumor proliferation rate. *Cyclin B1* was preferred instead of the housekeeping gene TATA-box binding protein (*TBP*) as the reference, since the former could be used to adjust both for the differences in the sample RNA concentration and differences in the tumor proliferation rate. The primer and probe sequences are shown in Table 6. For the two different BRCA1 isoforms (full length, i.e. with intact exon 11, and delta11b splice variant), the exonic location of the primers is indicated in parentheses after the primer sequences in Table 6, and the schematic presentation of the reactions is shown in Figure 7.

**Table 6.** The real-time RT-PCR primer and probe sequences for the *BRCA1*, *BRCA1*-delta11b and *Cyclin B1* genes. The location of the BRCA1 primers within the *BRCA1* gene sequence (the number of exon) is shown in parenthesis (III).

Gene	Primer sequences (5'→3')	Hybridization probe sequences (5'→3')
BRCA1 full length	TGCAGTGTGGGAGATCAAG (exon 9, 10 boundary) TGTCTCATGCTGTAATGAGC (exon 11b)	GTTGATGATGTTTCAGTATTTGTTACATCCGTC-Fluorescein Red705-CAGAAAATTCACAAGCAGCCTTTTTTG
BRCA1-delta11b	GGATGAAATCAGTTTGGATTCTG (exon 10) GCAGTCTTCAGAGACGCTTG (exon 12)	CACTCTCACACCCAGATGCTGCTTC-Fluorescein Red640-CCCTGATACTTTTCTGGATGCCTCTCA
Cyclin B1	AGGCCAAAATGCCTATGAAGA GGCTTGAGAGGCAGTAT	GTGTCTGAGCCAGTGCCAGAGCC-Fluorescein Red640-AACCTGAGCCAGAACCTGAGCCTG



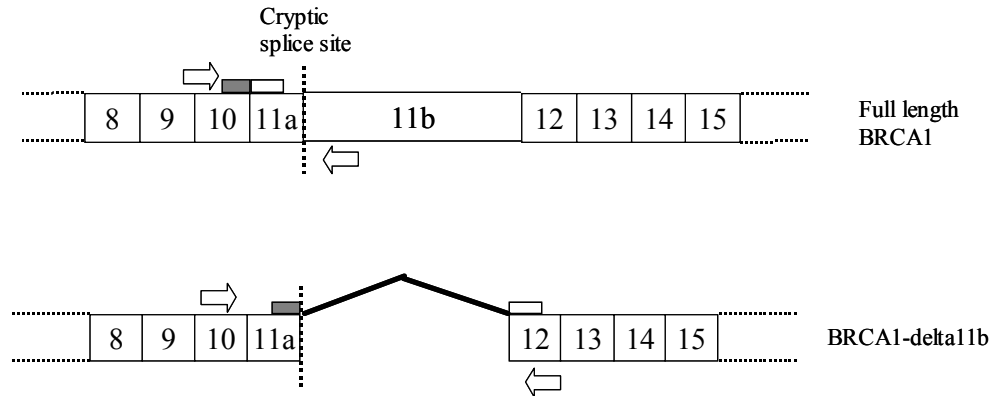

**Figure 7.** The structure of the detected BRCA1 mRNAs and the location of the cDNA primers used to amplify them. The primers are shown by arrows. The hybridization probes used to detect the variants in the real-time quantitative RT-PCR assay are shown as boxes (grey and open) (III).

The quantitative real-time RT-PCR reactions were performed with the Light Cycler (Wittwer et al. 1997) using the LC-FastStart DNA Hybridization Probes Kit (Roche Diagnostics, Mannheim, Germany). Thermocycling for each reaction was done in a final volume of 20  $\mu$ l containing 4  $\mu$ l of cDNA sample (diluted 1:4 from the original first-strand synthesis reaction) or standard, 2.5 mM MgCl<sub>2</sub>, 0.5  $\mu$ M of each primer, 0.2  $\mu$ M of fluorescein probe and 0.4  $\mu$ M of LC Red 640- or 705-labelled probes and finally 1X ready-to-use reaction mix containing Taq DNA polymerase, reaction buffer, and deoxynucleotide triphosphate mix. After 10 minutes of initial denaturation at 95°C, the cycling conditions of 45 cycles consisted of denaturation at 95°C for 10 sec, annealing for 5 sec at 55°C (*BRCA1* delta11b-isoform), 56°C (full-length *BRCA1*) and 58°C (*Cyclin B1*), and elongation at 72°C for 9 sec (*Cyclin B1* and *BRCA1* delta11b-isoform) and for 12 sec (full-length *BRCA1*).

The Light Cycler measured the fluorescence of each sample in every cycle at the end of the annealing step. After proportional background adjustment, the fit point method was used to determine the cycle in which the log-linear signal was distinguished from the background, and that cycle number was used as the crossing point value. The software produced the standard curve by measuring the crossing point of each standard and plotting them against the logarithmic values of concentrations.

#### **2.7.4. Immunoprecipitation and western blotting (IV)**

The xenograft was studied for BRCA1 protein expression. In order to collect both cytoplasmic and nuclear protein lysates, 50-100 mg of freshly frozen xenograft tumor sample was treated with 250-500  $\mu$ l of ice cold lysis buffer containing 0.25M NaCl, 0.1% NP40, 50mM Hepes, and 5mM EDTA with freshly added cocktail of protease inhibitors (10mM dithiothreitol, 1  $\mu$ g/ml aprotinin, 1  $\mu$ g/ml leupeptin, 0.2 mM phenylmethylsulfonyl fluoride). Xenograft sample was homogenized with tissue homogeniser at maximum speed three times for 5 sec. HBL-100 cells were treated with identical ice-cold lysis buffer with protease inhibitors as described above. Both samples were then incubated on ice for 30 min, passed through 21G needle and cleared from insoluble cellular debris by centrifugation. Protein concentrations were measured using the BIO-RAD DC Protein Assay (BIO-RAD Laboratories, USA) and lysates were stored at  $-70^{\circ}\text{C}$ .

Five hundred  $\mu$ g of xenograft and HBL-100 protein lysates were immunoprecipitated with both 10  $\mu$ g of Hybritech BR1S060.2 C-terminal BRCA1 antibody (Hybritech Inc., USA) and 6  $\mu$ g of MS110 N-terminal BRCA1 antibody (Oncogene Research Products). The following day, 20  $\mu$ l of Protein G PLUS-Agarose (Santa Cruz) was added for overnight incubation at  $4^{\circ}\text{C}$ . Then immunoprecipitates were collected by centrifugation and washed with lysis buffer, re-suspended in 30  $\mu$ l of 2X SDS loading buffer, run on a 5.5-6.5% SDS-polyacrylamide gel and transferred to nitrocellulose membrane (BIO-RAD Laboratories, USA). The immunoblot was blocked in 4% dry milk in Tris-buffered saline (TBS), 0.1% Tween (TBST). The membrane was immunoblotted with primary antibody BRCA1 MS110 (Oncogene Research Products). The blot was washed in 4% milk in TBST and incubated with HRP-conjugated secondary anti-mouse antibody (Calbiochem, USA). The blot was developed by SuperSignal West Pico Chemiluminescent Substrate (Pierce, USA).

#### **2.8. Gene expression profiling by cDNA microarrays (IV)**

Total RNA was extracted from frozen primary tumor, axillary node metastasis, tissues of different xenograft generations and cells using Trizol (InVitrogen) followed by RNeasy (Qiagen). A common human RNA control (Stratagene) was used for all hybridizations. For each hybridization 25  $\mu$ g sample RNA and 25  $\mu$ g common control RNA was used to generate aminoallyl-modified cDNA and differentially labeled by coupling Cy3 or Cy5 molecules to the cDNA according to the manufacturers recommendations (CyScribe Post-Labeling Kit, Amersham Pharmacia Biotech). A hybridization solution was prepared by combining labeled cDNA, 20  $\mu$ l Cot-1 DNA (1mg/ml), 3  $\mu$ l Poly dA<sub>40-60</sub> (4 mg/ml), 1.5  $\mu$ l yeast tRNA (4 mg/ml), dried down in a speed-vac and resuspended in 130  $\mu$ l DIG-Easy

(Roche)/1% BSA (Sigma). The hybridization solution was added to a prehybridized (1% BSA), microarray slide, incubated at 42°C for 17 h and washed with wash 1 (2XSSC, 0.1% SDS), wash 2 (1XSSC), wash 3 (0.1XSSC) and subsequently dried by centrifugation using a swing-out rotor.

Arrays were produced using PCR amplified DNA targets from Sequence Verified Human cDNA Clones (ResGen, Invitrogen Corporation). PCR products were verified by agarose gel electrophoresis and purified using size-exclusion filtration (Millipore). After purification, target was recovered in water and adjusted to 50% DMSO. Target DNA was printed on amino-silane coated glass slides (UltraGAPS, Corning) using a MicroGrid2 equipped with MicroSpot10K pins (BioRobotics). After hybridization and washing, arrays were scanned (Agilent DNA Microarray Scanner, Agilent Technologies), images were analyzed (Genepix Pro 3.0, Axon Instruments) and Cy3 and Cy5 intensities corrected for background were calculated using median feature and median local background intensities. Within array normalization was done using an implementation of the intensity-dependent normalization based on a lowest fit as previously described (Yang et al. 2002) and provided in the BioArray Software Environment (BASE) (Saal et al. 2002). Subsequent filter steps were performed within BASE to select for probes designated to individual UniGene clusters (<http://www.ncbi.nlm.nih.gov/UniGene/>), with a minimum intensity in both channels and presence in all hybridizations so that data from 3295 probes remained.

## **2.9. Statistical analyses (I-IV)**

In study I, the association of *BRCA1* or *BRCA2* deletion with AI at respective loci was analyzed using Fisher's Exact Test. In study II, the association of concomitant loss of *BRCA1* and *BRCA2* with hereditary form of breast cancer was studied using Pearson  $\chi^2$  test. In study III, the association of *BRCA1* gene copy number status or promoter hypermethylation with BRCA1 expression was studied using t-test. Multiple linear regression analysis was used to study the relation of co-variates to BRCA1 mRNA expression levels. Expression variables with grossly asymmetric distribution were log transformed before statistical analyzes. The association of *BRCA1* deletion with *ErbB2* gene copy number status, BRCA1 promoter hypermethylation or clinico-pathological characteristics was analyzed using Fisher's Exact Test. In study IV, Pearson correlation coefficients were calculated for comparison of gene expression profiles in the primary tumor, its axillary lymph node metastasis, different xenograft generations and the cell line.

## Results

### **1. Allelic imbalance and gene copy number changes (I, II)**

Allelic imbalance and actual gene copy number changes of the *BRCA1/2* genes were studied in hereditary and sporadic breast cancers. This aimed at gaining new information on somatic inactivation mechanisms of *BRCA1/2* in these two types of breast cancer.

#### **1.1. Hereditary breast tumors (I, II)**

##### **1.1.1. BRCA1 tumors (I, II)**

Fifteen breast cancers from germ-line *BRCA1* mutation carriers were analyzed for allelic imbalance at the *BRCA1* locus. According to defined criteria ( $L < 0.75$  or  $L > 1.33$ ), AI was found in 12 of the 15 tumors, whereas three tumors showed the ratio of alleles (L) between 0.77 - 0.83. These tumors showed abundant (>50%) non-malignant lymphocyte infiltrate in the sample and they were classified as having possible AI.

Seventeen breast cancers from germ-line *BRCA1* mutation carriers were analyzed for the *BRCA1* gene copy number by FISH. Both absolute and relative copy numbers (= copy number relative to chromosome 17 centromere) were determined. Eight tumors (8/17; 47.1%) showed deletions of the *BRCA1* gene with varying number of *BRCA1* gene copies. All these tumors showed allelic imbalance at the *BRCA1* locus. Two tumors showed a loss of an entire copy of chromosome 17, as indicated by single copies of *BRCA1* and chromosome 17 centromere (2/17; 11.8%). Four tumors (4/17; 23.5%) did not reveal any change in the relative *BRCA1* gene copy number, although they all showed allelic imbalance. Unexpectedly, three tumors (3/17; 17.6%) showed a copy number gain of the *BRCA1* gene. Taken together, all but two tumors showing AI or tendency for AI had multiple (2 to 4) copies of the *BRCA1* gene.

Constitutive DNA was obtained from a relative (also 2594delC germ-line mutation carrier) to one patient. The genotype analysis revealed that the shared smaller (mutant) *BRCA1* allele was retained in excess in the tumor sample. Thus, combined data from genotyping and FISH showed that this tumor contained a multiplied mutant *BRCA1* allele. Examples of both AI and FISH analyses of *BRCA1* gene in BRCA1 tumors are shown in Figure 8.

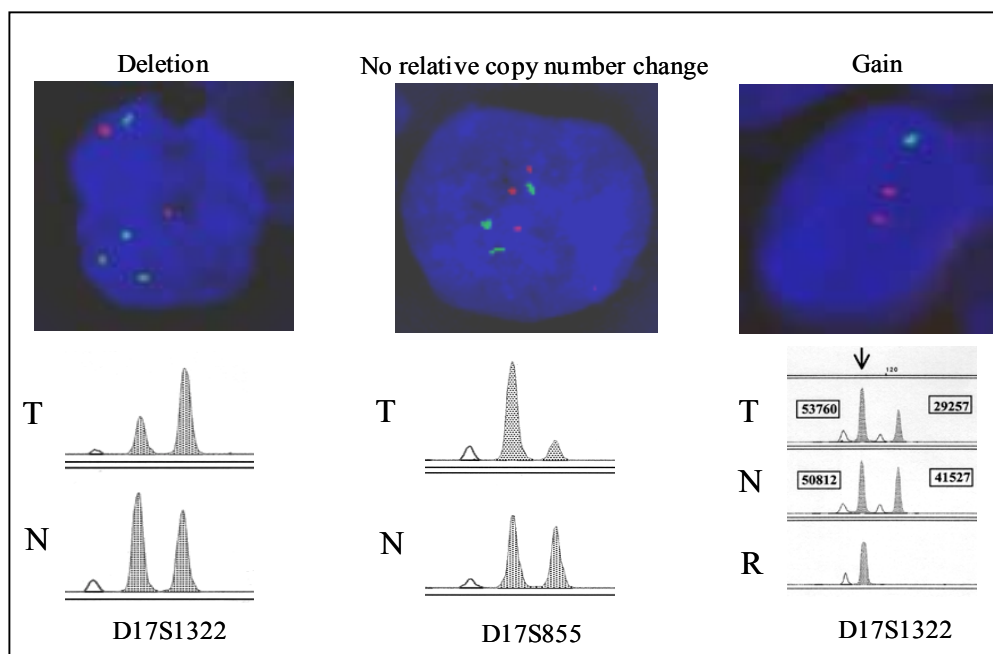

**Figure 8.** Examples of *BRCA1* gene copy number changes (upper panels) by FISH and concomitant AI at *BRCA1* (bottom panels) by capillary electrophoresis in breast tumors from germ-line *BRCA1* mutation carriers. Microsatellite markers used in AI analyses are shown below the panels of fragment analyses. Microsatellite analysis of relative blood DNA (homozygous for the marker used) shows that mutant allele is duplicated in tumor tissue. The mutant *BRCA1* allele is shown by an arrow (last panel). T = tumor, N = reference DNA (blood), R = DNA from a relative with a germ-line mutation, red fluorescent probe = *BRCA1* gene, green fluorescent probe = chromosome 17 centromere (I).

Thirteen *BRCA1* tumors were available for the analysis of AI at *BRCA2* and eleven of these tumors were informative. AI at *BRCA2* was found in 8 of the 11 (73%) informative *BRCA1* cases. All of the *BRCA1* tumors were also analyzed for *BRCA2* gene copy number by FISH. Three tumors showed a clear physical interstitial deletion of the *BRCA2* gene when *BRCA2* signals were compared to the reference gene (*ETB* gene at 13q22). If the overall ploidy level (= DNA index by flow cytometry) was used as a *BRCA2* copy number reference, six additional tumors showed a loss of *BRCA2*. This suggests a large deletion at 13q comprising both *ETB* and *BRCA2* genes. Thus, loss of the *BRCA2* gene by FISH was present in 53% (9/17) of the *BRCA1* tumors. All but one of the informative *BRCA1* tumors showing change in the relative *BRCA2* gene copy number showed also AI at *BRCA2*. Seven out of 17 (41%) of the *BRCA1* tumors did not reveal any relative *BRCA2* copy number change, although two of them showed AI of *BRCA2*. One tumor (1/17; 6%) showed a copy number gain of the *BRCA2* gene but this tumor was not available for AI analysis. The

## RESULTS

detailed AI and FISH analyses of both *BRCA1/2* genes in *BRCA1* tumors are summarized in table 7.

**Table 7.** AI and FISH analyses in *BRCA1*-mutation tumors (I, II).

Tumor	<i>BRCA1</i> mutation	AI at <i>BRCA1</i>	Interpretation of the <i>BRCA1</i> gene copy number status (chr 17 cen: <i>BRCA1</i> signals)	AI at <i>BRCA2</i>	Interpretation of the <i>BRCA2</i> gene copy number status by FISH (compared to both DNA-index and <i>ETB</i> ) ( <i>ETB:BRCA2</i> signals)
Ca 14510	300T→G	Yes	No relative change (3:3 or 4:4)	Yes	Large 13q deletion (2:2, 3:3)
Ca 11394	1177G→A	NA	No relative change (2:2)	NA	No relative change (2:2, 3:3)
Ca 08822	1201del11	Yes	No relative change (3:3 or 2:2)	NA	No relative change (3:3)
Ca 08571	1806C→T	Yes	<i>BRCA1</i> deletion (4:3 or 4:2)	No	No relative change (3:3)
Ca 10581	1806C→T	Yes	<i>BRCA1</i> deletion (3:2)	NI	<i>BRCA2</i> deletion (4:2)
Ca 12 224	1806C→T	Yes	<i>BRCA1</i> deletion (3:2)	Yes	Large deletion at 13q (3:3)
Ca 13996	1806C→T	Yes	Monosomy of chr 17 (1:1)	Yes	No relative change (2:2)
Ca 09252	2594delC	Yes	<i>BRCA1</i> deletion (3:2)	Yes	<i>BRCA2</i> deletion (3:2)
Ca 12421	2594delC	NA	<i>BRCA1</i> deletion (4:2)	NA	Gain of <i>BRCA2</i> (3:4)
Ca 14970	2594delC	Yes	Gain of <i>BRCA1</i> (1:2)	Yes	No relative change (2:2)
Ca 10360	3172ins5	Yes	<i>BRCA1</i> deletion (3:2)	Yes	Large deletion at 13q (2:2)
Ca 14007	3172ins5	Yes	<i>BRCA1</i> deletion (4:2)	Yes	<i>BRCA2</i> deletion (3:2)
Ca 14090	3172ins5	Yes	Monosomy of chr 17 (1:1)	No	No relative change (2:2)
Ca 11808	3829delT	Yes	Gain of <i>BRCA1</i> (1:2)	Yes	Monosomy of 13q (1:1)
Ca 13812	4808C→G	Yes	No relative change (3:3)	NI	Large deletion at 13q (2:2)
Ca 13714	5328insC	Yes	<i>BRCA1</i> deletion (4:3)	No	Large deletion at 13q (3:3)
Ca 10697	Linkage+	Yes	Gain of <i>BRCA1</i> (3:4)	NA	No relative change (3:3)

(NA = not available, NI = not informative, chr 17 cen= chromosome 17 centromere)

### 1.1.2. *BRCA2* tumors (I, II)

Five of six *BRCA2* tumors (83%) showed AI at the *BRCA2* locus. Eight breast cancers from germ-line *BRCA2* mutation carriers were analyzed by FISH. Five tumors (5/8; 62.5%) showed a physical deletion of the *BRCA2* gene, when the copy numbers were compared to that of the *ETB* gene (located at 13q22). When the overall ploidy level (= DNA index by flow cytometry) was used as a copy number reference, two of the remaining three tumors showed a copy number imbalance suggesting that both *BRCA2* and *ETB* had been deleted. One tumor did not show *BRCA2* copy number change by FISH compared to *ETB* or tumor ploidy, although it showed AI. Genotype analysis of the family member showed retained mutated *BRCA2* allele (2024del15) in this tumor. Examples of both AI and FISH analyses of *BRCA2* gene in *BRCA2* tumors are shown in Figure 9.

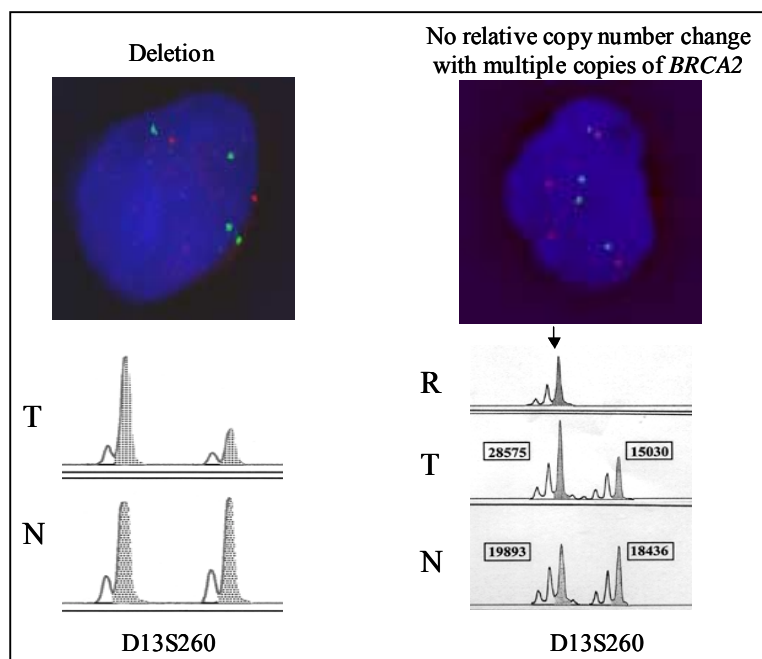

**Figure 9.** Examples of *BRCA2* gene copy number changes (upper panels) by FISH and concomitant AI at *BRCA2* (bottom panels) by capillary electrophoresis in breast tumors from germ-line *BRCA2* mutation carriers. Microsatellite markers used in AI analyses are shown below. Microsatellite analysis of relative blood DNA (homozygous for the marker used) shows that mutant allele is present at multiple copies in tumor tissue. The mutant *BRCA2* allele is shown by an arrow (last panel). T = tumor, N = reference DNA (blood), R = DNA from a relative with a germ-line mutation, red fluorescent probe = *BRCA2* gene, green fluorescent probe = *ETB* gene probe (I).

Five of the available six *BRCA2* tumors (83%) showed AI at the *BRCA1* locus. All of the *BRCA2* tumors were also analyzed for the *BRCA1* gene copy number changes by FISH. Four *BRCA2* tumors (4/8; 50%) showed physical deletion of the *BRCA1* gene. All the informative cases with deletion of *BRCA1* showed AI at *BRCA1*. Four of eight (50%) tumors revealed no relative *BRCA1* copy number change, yet two of these cases showed AI of *BRCA1*. AI and FISH analyses of both *BRCA1/2* genes in *BRCA2* tumors are summarized in Table 8.

## RESULTS

**Table 8.** AI and FISH analyses in *BRCA2*-mutation tumors (I, II).

Tumor	<i>BRCA2</i> mutation	AI at <i>BRCA2</i>	Interpretation of the <i>BRCA2</i> gene copy number status (compared to both DNA-index and <i>ETB</i> ) ( <i>ETB:BRCA2</i> signals)	AI at <i>BRCA1</i>	Interpretation of the <i>BRCA1</i> gene copy number (chr 17 cen: <i>BRCA2</i> signals)
<b>Ca 11900</b>	2024del5	Yes	No relative change (4:4)	Yes	<i>BRCA1</i> deletion (5:2)
<b>Ca 14486</b>	2024del5	Yes	<i>BRCA2</i> deletion (2:1)	Yes	<i>BRCA1</i> deletion (4:2)
<b>Ca 11787</b>	3058A→T	Yes	<i>BRCA2</i> deletion (3:2)	Yes	No relative change (4:4)
<b>Ca 13816</b>	3058A→T	Yes	Large deletion at 13q (1:1)	Yes	Monosomy of chr 17 (1:1)
<b>Ca 10588</b>	4486delG	NA	<i>BRCA2</i> deletion (2:1)	NA	<i>BRCA1</i> deletion (2:1)
<b>Ca 11721</b>	5445del5	NA	<i>BRCA2</i> deletion (2:1)	NA	No relative change (3:3)
<b>Ca 07936</b>	6293C→G	No	<i>BRCA2</i> deletion (2:1 or 3:2)	Yes	No relative change (2:2)
<b>Ca 11506</b>	6293C→G	Yes	Large deletion at 13q (2:2 or 3:3)	No	No relative change (2:2)

(NA=not available, NI=not informative, chr 17 cen= chromosome 17 centromere)

### 1.2. Sporadic breast tumors (I)

Eleven sporadic breast cancers were analyzed for the *BRCA1* gene copy number and AI at the *BRCA1* locus (I). AI was detected in eight tumors (8/11, 73%), and a physical deletion of the *BRCA1* gene in six of these. This means that two tumors showed AI but no change in the *BRCA1* gene copy number by FISH. Ten sporadic breast cancers were examined for the *BRCA2* gene copy number and AI at the *BRCA2* locus (I). AI at the *BRCA2* locus was found in seven tumors (7/10, 70%). A physical deletion of the *BRCA2* gene was identified in five tumors by FISH (5/10, 50%) and in one additional tumor when overall ploidy level was used as a reference indicating a large 13q deletion. Similar to the *BRCA1* results, all the cases that showed deletion of the *BRCA2* gene by FISH showed AI at the *BRCA2* locus. One case with AI showed no relative change in the *BRCA2* gene copy number by FISH (when one case with large deletion at 13q is included in the analysis). Statistically, physical deletion of *BRCA1* or *BRCA2* correlated with AI at *BRCA1/2* loci, respectively (Fisher's Exact Test,  $p=0.061$  and  $p=0.033$ , respectively). The AI and FISH analyses of the *BRCA1/2* genes in sporadic breast cancers are shown in Table 9.



**Table 9.** AI and FISH analyses in sporadic breast tumors (I).

Case number	AI at BRCA1	Interpretation of the BRCA1 gene copy number (chr 17 cen:BRCA2 signals)	Case number	AI at BRCA2	Interpretation of the BRCA2 gene copy number status, compared to both DNA-index and ETB (ETB:BRCA2 signals)
<b>6422</b>	No	No relative change (2:2)	<b>7105</b>	No	No relative change (2:2)
<b>6755</b>	No	No relative change (2:2)	<b>7118</b>	No	No relative change (2:2)
<b>6762</b>	No	No relative change (2:2)	<b>7119</b>	No	No relative change (3:3)
<b>6591</b>	Yes	No relative change (2:2)	<b>7356</b>	Yes	No relative change (2:2)
<b>6930</b>	Yes	No relative change (4:4)	<b>8661</b>	Yes	Large deletion at 13q (3:3)
<b>6686</b>	Yes	BRCA1 deletion (4:2)	<b>7071</b>	Yes	BRCA2 deletion (4:3)
<b>6697</b>	Yes	BRCA1 deletion (4:2)	<b>7685</b>	Yes	BRCA2 deletion (2:1)
<b>6797</b>	Yes	BRCA1 deletion (4:2)	<b>8663</b>	Yes	BRCA2 deletion (2:1 or 3:2)
<b>6947</b>	Yes	BRCA1 deletion (4:2)	<b>9021</b>	Yes	BRCA2 deletion (4:2 or 4:3)
<b>6991</b>	Yes	BRCA1 deletion (4:2)	<b>11310</b>	Yes	BRCA2 deletion (4:2)
<b>7015</b>	Yes	BRCA1 deletion (4:3)			

(chr 17 cen = chromosome 17 centromere)

## 2. Concomitant loss of the *BRCA1/2* genes (II)

Concomitant loss of *BRCA1/2* was studied in hereditary and sporadic breast cancers. Fourteen primary sporadic breast cancers were analyzed for both *BRCA1* and *BRCA2* gene copy number changes by FISH. Deletion of both *BRCA1/2* genes was detected by FISH in four sporadic tumor samples (4/14, 29%). Taken together both hereditary *BRCA1/2* tumors, combined AI at both *BRCA1/2* loci was detected in twelve out of seventeen hereditary cases (71%). The difference in concomitant loss of the *BRCA1/2* genes between hereditary and sporadic breast cancer tumors was statistically significant (Pearson  $\chi^2$ ,  $p=0.02$ ).

## 3. *BRCA1* deletions, promoter hypermethylation and expression in sporadic breast cancers (III)

The possible involvement of *BRCA1* in the pathogenesis of sporadic breast cancer was analyzed by studying the frequency of somatic re-arrangements (physical deletions) and promoter hypermethylation of the *BRCA1* gene in a set of primary sporadic breast cancers. The impact of both genetic and epigenetic alterations on *BRCA1* expression status was also evaluated.

## RESULTS

### 3.1. *BRCA1* deletions (III)

Twenty-seven of sixty tumors analyzed (45%) showed physical deletion of the *BRCA1* gene. Deletion was mostly present as a copy number ratio of 4:2 (four copies of 17 centromere: 2 copies of *BRCA1*; Figure 10A), but also as 2:1 (diploid tumors with one *BRCA1* gene copy) and as 1:1 (monosomy of chromosome 17). Thirty-three tumors (55%) didn't show any relative *BRCA1* gene copy number change (=equal number of *BRCA1* and chromosome 17 centromere signals; Figure 10B). There was a statistically significant association between *BRCA1* deletion and *ErbB2* oncogene amplification (Fisher's Exact Test,  $p=0.001$ ) and *BRCA1* deletion and tumor aneuploidy (Fisher's Exact Test,  $p=0.037$ ), but *BRCA1* deletion did not associate with histological grade, lymph node status or hormone receptor staining.

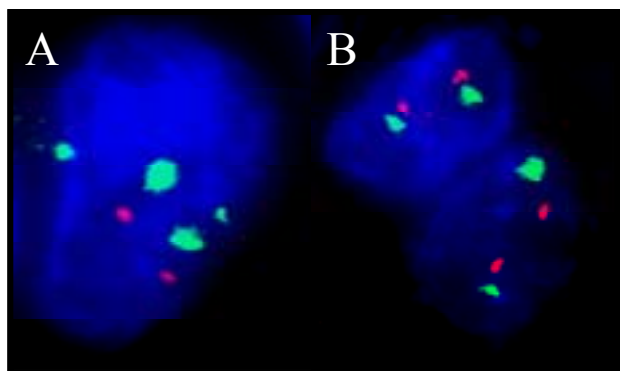

**Figure 10.** Two-color FISH analysis of *BRCA1* (red fluorescent signals) and chromosome 17 centromere (green fluorescent signals) in sporadic breast cancers. Tumor nuclei were counterstained with DAPI (blue). Physical deletions of the *BRCA1* gene (=loss of *BRCA1*) were mostly detected by FISH as 4:2 *BRCA1* deletions (panel A). An example of a sporadic breast cancer with no relative *BRCA1* gene copy number change (= equal number of *BRCA1* and chromosome 17 centromere signals) is shown in panel B (III).

The relative expression levels of full-length *BRCA1* mRNA were studied in 56 sporadic breast cancers. The median expression levels of full-length *BRCA1* mRNA in tumors with *BRCA1* deletion were one third of that in tumors with no *BRCA1* deletion (4.5 vs. 13.5,  $p<0.0001$ ). Expression levels of full-length *BRCA1* mRNA were similar in tumors with *BRCA1* deletion regardless of the absolute *BRCA1* gene copy number (two alleles vs. one allele;  $p=0.994$ ). The relative expression levels of *BRCA1*-delta11b splice variant mRNA were also analyzed. The expression levels of *BRCA1*-delta11b mRNA correlated strongly with full-length *BRCA1* mRNA levels (Pearson  $r=0.89$ ). *BRCA1* deletions and low levels of *BRCA1*-delta11b mRNA showed also a significant association ( $p=0.003$ ).

### **3.2. BRCA1 promoter hypermethylation (III)**

Promoter hypermethylation of the *BRCA1* gene was studied in 53 tumors by methylation-specific PCR. Six out of 53 tumors (11%) showed BRCA1 promoter hypermethylation. BRCA1 promoter hypermethylation was not associated with *BRCA1* deletion (Fisher's Exact Test,  $p=0.668$ ) or with other clinico-pathological variables. The median expression levels of full-length BRCA1 mRNA in tumors with BRCA1 promoter hypermethylation were six times lower than in tumors without hypermethylation (1.2 vs. 7.3,  $p=0.005$ ). Low expression levels of BRCA1-delta11b mRNA also associated with BRCA1 promoter hypermethylation ( $p=0.017$ ).

### **3.3. Regression model of full-length BRCA1 mRNA expression (III)**

A statistical multivariate analysis was performed to study whether *BRCA1* deletion status has an independent effect on BRCA1 mRNA expression. In a multiple regression analysis, decreased levels of BRCA1 expression showed strongest association with *BRCA1* deletion ( $p<0.0001$ ), followed by negative PgR status ( $p=0.020$ ) and BRCA1 promoter hypermethylation ( $p=0.041$ ). The variation in BRCA1 expression was not dependent on histological grade or ER status. R square value was 0.46 indicating that this regression model explains ca. 45% of the total variation in expression levels of BRCA1 mRNA.

## **4. Preparation of the xenograft and cell line (IV)**

Experimental mouse xenograft (L56Br-X1) and cell line (L56Br-C1) models derived from breast cancer tumor of a patient with germ-line *BRCA1* mutation were established and characterized. These model systems were established in order to obtain tools for future purposes of studying BRCA1 function and therapeutical aspects of BRCA1 tumors.

A serially transplantable subcutaneous mouse xenograft, designated L56Br-X1, was established from a breast cancer lymph node metastasis of the patient with *BRCA1* germ-line mutation 1806C→T (Gln563Stop). After seven xenograft generations eight to nine tumors started to grow successfully when xenograft tumor samples were inoculated subcutaneously in ten mice. The mean tumor-doubling rate was 13 days in xenograft generation eleven. No macroscopically detectable metastases have been found in any xenograft mice so far. A breast cancer cell line, designated L56Br-C1, was established from tumor tissue derived from xenograft generation 6. The cells grow as an adherent monolayer to confluence, with a population doubling time of approximately 27 hours during

## RESULTS

exponential growth phase. The cell line displayed a constant rate of cell death (detached and floating cells) with about 4% of the cells found in the pre-G1 region as determined by DNA flow cytometry (Hegardt et al. 2002). The L56Br-C1 cells have undergone several passages and show continuous growth, even after recovery from cryo-preservation. L56Br-C1 shows a malignant-like irregular growth pattern in 3D gels, which is in line with the histopathology seen in L56Br-X1 xenograft. Injection of L56-BR-C1 cells subcutaneously in nude mice leads to formation of new xenograft tumors.

### **4.1. Analysis of the *BRCA1* gene status (IV)**

The presence of a germ-line mutation in exon 11 of *BRCA1*, 1806C→T (Gln563Stop), was verified in blood cells from the patient and was shown to be retained in a hemizygous state in the primary tumor tissue as well as in the L56Br-X1 xenograft and L56Br-C1 cell line. The mutation is a known Swedish founder mutation (Johannsson et al. 1996) that has also been found elsewhere in Europe and North America. FISH analysis with probes to *BRCA1* and chromosome 17 centromere showed a single copy of each, indicating monosomy of chromosome 17 in the L56Br-X1 xenograft and, thus, a loss of the wild-type *BRCA1* allele.

### **4.2. Karyotype analysis (IV)**

Cytogenetic analysis of the L56Br-C1 cell line revealed a complex karyotype with numerous marker chromosomes. The chromosome number varied between 63-66. With spectral karyotyping (SKY) a complete karyotype was generated leaving no marker chromosomes of unknown origin. The L56Br-C1 cell line and L56Br-X1 xenograft revealed similar patterns of aberrations by CGH analysis as the primary tumor. Thus, the CGH aberrations have remained stable during the establishment of the L56Br-X1 xenograft and L56Br-C1 cell line.

### **4.3. Histopathology and tumor biological characteristics (IV)**

Histological examination of the primary cancer, the lymph node metastasis and L56Br-X1 xenograft tumors revealed a poorly differentiated adenocarcinoma with no ductal differentiation. The growth pattern was characterized by pushing border type of tumor margins and small foci of necrosis at the tumor center. No significant change has occurred with regard to histopathological features during the evolution of the L56Br-X1 xenograft thus far. The primary cancer, L56Br-X1 xenograft and L56Br-C1 cell line contain multinucleated cells. The L56Br-C1 cell line has the appearance of small to medium sized

epitheloid cells with variations in nuclear size similar to the primary tumor. No cytoplasmic vacuoles, such as those described for the *BRCA1* mutated cell line HCC1937 (Tomlinson et al. 1998) were noted.

Immunostaining of the primary tumor and the L56Br-X1 xenograft revealed no differences, either between the primary tumor and the xenograft, or between different xenograft generations (generations 4, 6 and 9). The primary tumor and the different L56Br-X1 xenograft generations were immunohistochemically negative for ER, PgR, ERBB2, and EGFR with 0% positive cells. The L56Br-X1 xenograft was also negative for keratin 8 immunoreactivity. The proliferation antigen Ki67 and TP53 were strongly positive with 60-70% and 90-100% positive cells, respectively. Sequence analysis of *p53* in the primary tumor revealed a somatic nucleotide substitution (G → T) in exon 6 at position 644, which gives rise to a missense mutation, Ser215Ile. This mutation was present also in the L56Br-X1 xenograft and L56Br-C1 cell line. DNA flow cytometry of the primary tumor and the lymph node metastasis revealed a hypodiploid tumor with a DNA index of 0.85. This DNA index remained stable throughout the establishment of the L56Br-X1 xenograft. FISH analyses of *BRCA1* (17q21) and *p53* (17p13) and chromosome 17 centromere in the L56Br-X1 xenograft revealed the presence of a single copy of each, indicating monosomy of chromosome 17. No relative gene copy number change was noticed regarding *BRCA2* by FISH. Flow cytometric analysis of the L56Br-C1 cell line revealed it to be aneuploid with a DNA index of 1.75, indicating that it has developed by polyploidization of L56Br-X1.

#### **4.4. Expression analyses of the xenograft and cell line (IV)**

##### **4.4.1. Expression of BRCA1 mRNA and BRCA1 protein (IV)**

The L56Br-X1 xenograft expressed the full length mutant *BRCA1* mRNA, as well as the variants delta9,10, delta9,10,11b and delta11b. The mRNA expression of the L56Br-X1 xenograft was similar to HBL-100 cell line (a control with wild-type *BRCA1*). No PCR products were obtained in any of the negative PCR controls (reverse transcriptase negative and mouse cDNA samples).

Whereas HBL-100 control cells expressed a BRCA1 protein of 220 kDa (corresponding to the full length BRCA1 protein (Chen et al. 1996)), detected by immunoprecipitation and western blotting both with antibodies to N- and C-terminal parts of the BRCA1 protein, no BRCA1 proteins were detected in the L56Br-X1 xenograft. No protein products at 100-110 kDa, corresponding to the variant lacking most of exon 11 (including 1806C→T), were observed, either in L56Br-X1 xenograft or in control HBL-100 cells. Moreover, no

## RESULTS

evidence of truncated protein products was detected with the N-terminal MS110 BRCA1 antibody in the L56Br-X1 xenograft.

### **4.4.2. Gene expression profiling (IV)**

Microarray analysis was performed to study gene expression profiles in the primary tumor, lymph node metastasis, L56Br-X1 xenograft and L56Br-C1 cell line. Similarity of gene expression profiles was assessed by calculating Pearson correlation coefficients between data sets of intensity ratios. Highest correlation was observed between the primary tumor, the lymph node metastasis and an early generation of the xenograft (generation 4). Slightly lower correlation was observed when the primary and lymph node tumors were compared to a later generation xenograft (generation 22). The L56Br-C1 cell line showed similar correlation to either L56Br-X1 xenograft generations or the lymph node metastasis but slightly less correlation to the primary tumor. In addition, a cluster analysis of expression profiles showed close relationship of the L56Br-C1 cell line and L56Br-X1 xenograft to the parental tumor samples.

## Discussion

### **1. Mechanisms for allelic imbalance (I, II)**

According to the classical two-hit paradigm (Knudson 1971), cancer predisposing gene loci (later named as TS gene loci) are considered to undergo genetic re-arrangements resulting in AI or LOH. In hereditary forms of cancer, germ-line mutations and subsequent physical deletions of the wild-type alleles are suggested to represent these genetic re-arrangements, while in sporadic cancers physical deletions are suggested to associate with somatic mutations. The event or series of events leading to AI or LOH can, however, result from several other mechanisms than physical deletion, such as mitotic recombination, non-disjunctional chromosomal loss with or without reduplication, and gene conversion (reviewed in Levine 1993). While previous studies have almost invariably shown LOH at *BRCA1/2* loci in breast tumors from germ-line mutation carriers (Smith et al. 1992, Neuhausen and Marshall 1994, Collins et al. 1995) and frequently in sporadic breast tumors (Phelan et al. 1998, Rio et al. 1998), less is known about the mechanisms behind AI or LOH at *BRCA1/2*. The relationship between AI and actual gene copy numbers of *BRCA1* and *BRCA2* by FISH was studied in a set of hereditary breast cancers derived from both germ-line *BRCA1* and *BRCA2* mutation carriers. All the informative tumors with germ-line *BRCA1* mutation and all but one tumor with *BRCA2* mutation showed AI at the corresponding loci, which is in concordance with previous studies (Smith et al. 1992, Collins et al. 1995) and favors the role of *BRCA1/2* as TS genes.

The analysis of gene copy numbers revealed that simple physical deletions do not seem to be the predominant mechanisms resulting in AI at *BRCA1/2*. The FISH analyses indicated a copy number reduction to a single *BRCA1/2* gene copy in 2/17 (12%) *BRCA1* and 4/8 (50%) *BRCA2* tumors. Thus, copy number patterns of higher complexity seem to be a common phenomenon, especially in *BRCA1* tumors. Reductions in relative *BRCA1/2* gene copy number (gene copy number compared to reference; also defined as physical deletions) were detected in 8/17 *BRCA1* tumors (47%) and 3/8 *BRCA2* tumors (38%), respectively. In these cases, multiple (2 or 3) copies of *BRCA1/2* genes were detected. It has been reported that breast cancer tumor aneuploidization occurs mainly via reduplication, and involves intact as well as partly deleted and otherwise re-arranged chromosomal regions (reviewed in Devilee and Cornelisse 1994, Rennstam et al. 2001). Thus, the copy number ratios detected (reference / *BRCA1* or *BRCA2* = 4:2, 3:2, 4:3) suggest that specific physical deletions occur first at *BRCA1/2* loci, which is then followed by polyploidization (ploidy shift of the whole tumor genome) resulting in duplication of the remaining mutant allele.

## DISCUSSION

Furthermore, possibly other genetic re-arrangements follow polyploidization resulting in 4:3 or 3:2 copy number ratios.

Interesting findings were made in 4/17 (24%) BRCA1 and in 1/8 (12,5%) BRCA2 tumors, which showed AI without relative gene copy number changes. The absolute gene copy number of *BRCA1* and *BRCA2* was 2-4 in all of these tumors. Additionally, three BRCA1 tumors showed even a copy number gain of *BRCA1* (2 and 4 copies of the gene). Microsatellite and segregation analyses were carried out in one BRCA1 and one BRCA2 tumor and they confirmed that multiple *BRCA1/2* alleles were mutant. One could speculate that late-occurring somatic aberrations, like chromosome arm duplication or gene amplification nearby could lead to secondary multiplication of mutant *BRCA1* or *BRCA2*. It has been reported, however, that the *ERBB2* oncogene, located nearby *BRCA1* at 17q12-q21, is almost never amplified in hereditary BRCA1 tumors (Johannsson et al. 1997). The presence of microdeletions could be involved in the inactivation of the *BRCA1/2* genes in cases, which showed equal number of test and reference probes. This possibility could have been completely ruled out only by genomic sequencing, which was not performed in this study and can be regarded as a limitation.

The results of our study suggest that wild-type *BRCA1* and *BRCA2* alleles can be inactivated not only by physical deletions, but also by alternative mechanisms, since AI can be detected without any reduction (absolute or relative) in the gene copy number (reviewed in Meuth 1990, Stanbridge 1990, and Levine 1993). These alternative mechanisms leading to AI seem to be common in breast tumors especially from *BRCA1* mutation carriers and at least present in BRCA2 tumors. Studies on other tumor types and TS genes have shown that mitotic recombination can often be involved in TS gene inactivation. Recombinational events have been associated with *RBI* inactivation in retinoblastoma (Cavenee et al. 1983) and with both *p53* and *RBI* in sporadic breast cancer tumors (Murthy et al. 2002). Mouse studies on Bloom syndrome have shown that globally increased rate of LOH resulting from mitotic recombination constitutes the mechanism leading to tumor susceptibility in these mice (Luo et al. 2000). Interestingly, BRCA1 and BLM have been reported to interact suggesting functions in same pathways (Wang et al. 2000b). It cannot be ruled out, however, whether BRCA1/2 breast tumors show signs of recombinational or non-disjunctional events at *BRCA1/2* loci simply due to global chromosomal instability, which has been associated with loss of BRCA1/2 function *per se*. However, if the chromosomal instability is emphasized as the primary cause of alternative mechanisms leading to AI or LOH detected in our study, one might not expect hereditary BRCA1 tumors to show such a specific tumor phenotype that has been previously reported (Johannsson et al. 1997, Loman et al. 1998).



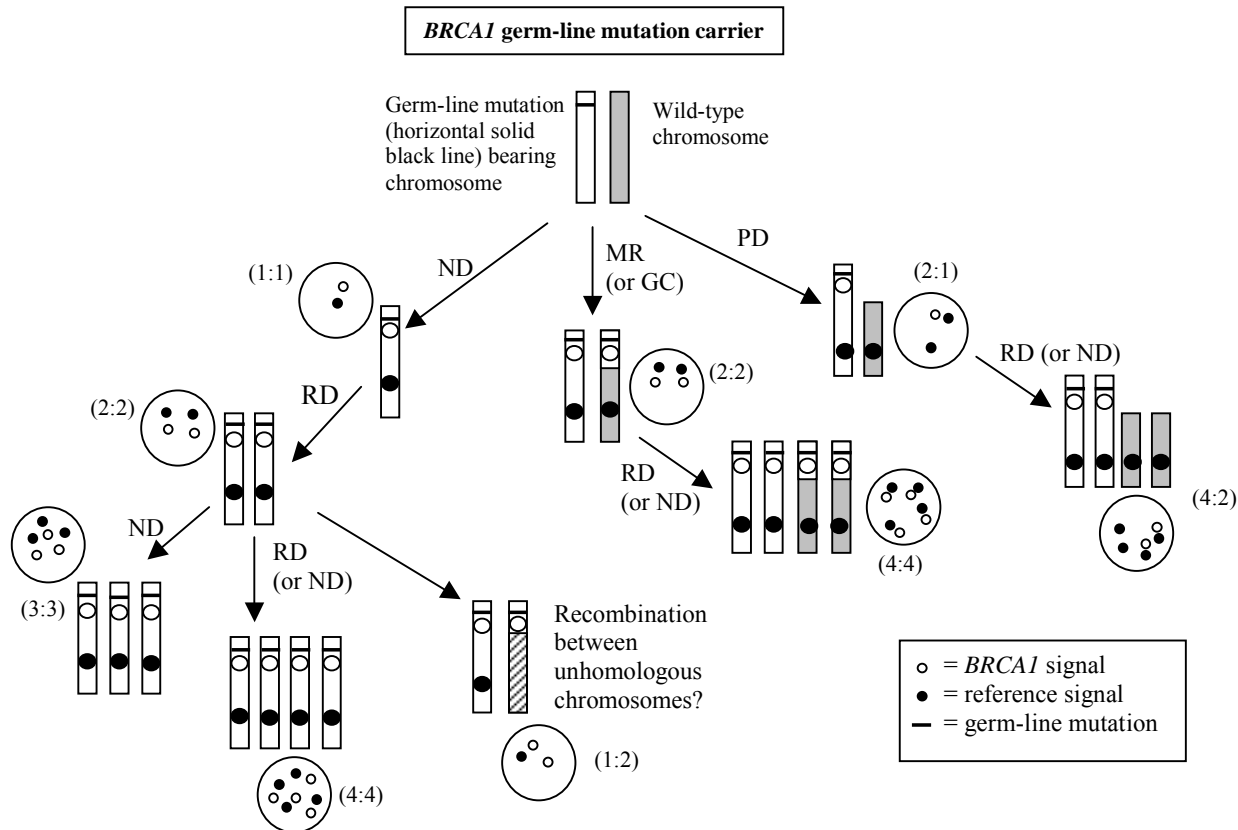
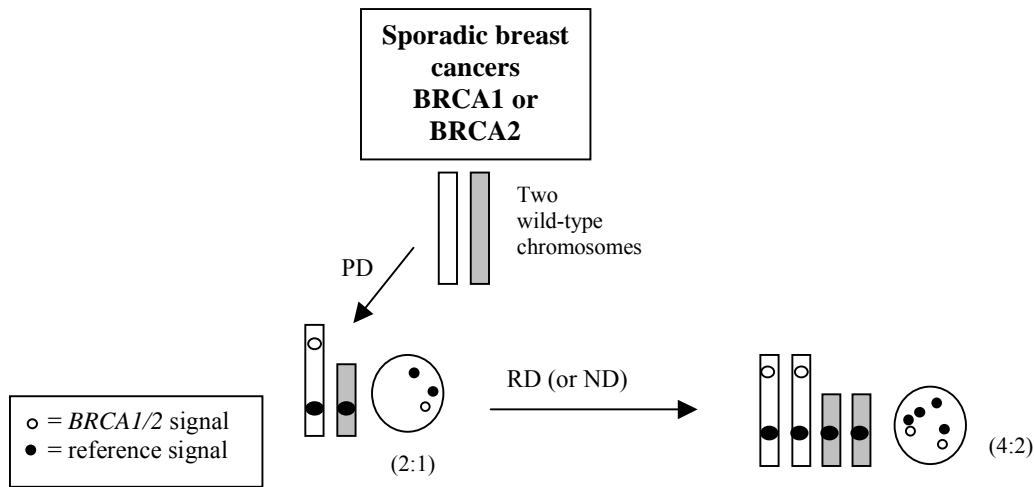

**Figure 11.** Possible mechanisms leading to AI at *BRCA1/2* loci in breast tumors from *BRCA1* mutation carriers. Two parental chromosomes are presented as white or grey boxes and germ-line mutation is presented by a solid black line. Next to the boxes representing chromosomes, a schematic presentation of the appearance of a FISH interphase nucleus is shown. The copy number ratios are indicated in parenthesis (reference:*BRCA1* signal). Solid black dot signal corresponds to reference probe and open dot signal corresponds to gene-specific (target) probe (*BRCA1* or *BRCA2*). ND = non-disjunction, RD = reduplication, MR = mitotic recombination, GC = gene conversion, PD = physical deletion.

In comparison to sporadic breast tumors, the complex pattern of genetic re-arrangements leading to AI seem to be a specific feature of hereditary breast cancer tumors, at least in the case of *BRCA1* mutation carriers. The comparison of *BRCA2* tumors to sporadic tumors is in turn hampered by small sample size. However, it can be concluded from the findings regarding sporadic breast tumors that AI and physical deletions correlated well. *BRCA1/2* deletions were mostly of 4:2 or 3:2 copy number ratios indicating that physical deletion has occurred before reduplication of the tumor genome. These findings suggest that sporadic breast tumors are also quite unstable at genomic level (frequent polyploidization) similar to hereditary tumors, but yet sporadic cancers show physical deletion as the predominant mechanism for AI at *BRCA1/2* loci. Taken together, these findings suggest that at least in *BRCA1* tumors, the mechanisms leading to AI at both *BRCA1/2* loci are varied and more

## DISCUSSION

complex (such as non-disjunction, recombination) compared to sporadic cancers (mainly physical deletion). Thus, these results could reflect the inactivation of different and specific pathways, such as recombinational DNA repair pathways, in different forms of breast cancer. The method used in this study, however, does not enable the distinction between non-disjunction and recombination events. This could have been accomplished by the use of more distal microsatellite markers in the analyses of BRCA1 tumors.



**Figure 12.** Predominant mechanisms leading to AI at *BRCA1/2* loci in sporadic breast tumors. Two parental chromosomes are presented as white or grey boxes. Next to the boxes representing chromosomes a schematic presentation of the appearance of a FISH interphase nucleus is shown. The copy number ratios are also indicated in parenthesis (reference:*BRCA1/2* signal). Solid black dot signal corresponds to reference probe and open dot signal corresponds to gene-specific (target) probe at either *BRCA1* or *BRCA2* locus. ND = non-disjunction, RD = reduplication, PD = physical deletion.

### **2. Multiple mutant copies of the *BRCA1/2* genes (I)**

Interestingly, multiple mutant *BRCA1/2* copies were detected in many *BRCA1* tumors and in some *BRCA2* tumors. Based on this, it can be suggested that some mutant *BRCA1* and *BRCA2* alleles may have oncogenic potential. Dominant negative mutant TS alleles could promote oncogenesis by blocking the function of the remaining wild-type TS alleles, for example by formation of non-functional hetero-oligomers or interfering with protein-protein interactions, which could explain the selection for mutant allele multiplication. All but one of the *BRCA1* and *BRCA2* mutants analyzed in our study give rise to a premature stop codon in the transcript and thus to truncated protein products that are thought to be non-functional due to loss of essential domains involved in transcriptional regulation, DNA

repair or nuclear localization (reviewed in Zheng et al. 2000a). Furthermore, it has been suggested that cells preferably produce only the full-length proteins and destroy mRNA molecules containing premature stop codons by nonsense-mediated mRNA decay (reviewed in Byers 2002) suggesting that multiple copies of mutant *BRCA1/2* would not necessarily be reflected in expression levels at all. Most of the samples analyzed in our study contained *BRCA1* mutations in the central exon 11, which is spliced out in *BRCA1*-delta11b mRNA variant present in many tissues (Lu et al. 1996, Wilson et al. 1997). It could be hypothesized that these tumors with truncating mutation in exon 11 could undergo nonsense mediated mRNA exon skipping (Mazoyer et al. 1998, Liu et al. 2001) and multiple copy numbers could then be reflected in an increase in variant mRNA. This seems unlikely, since it was recently reported that lymphoblastoid cell lines derived from *BRCA1* mutation carriers showed degradation of most *BRCA1* mRNAs containing premature termination codons (Perrin-Vidoz et al. 2002). However, *in vitro* studies have shown that ectopic expression of truncated or mutated full-length *BRCA1* genes inhibited the function of wild-type *BRCA1* (Fan et al. 2001b). Murine studies have also shown that ectopically expressed *BRCA1*-delta11b and truncated mutant *BRCA1* proteins have dominant negative effects (Bachelier et al. 2002). These reports could indicate that if nonsense-mediated mRNA decay could be escaped and truncated proteins translated, they might have an active role in tumor progression. It should be noted that both *BRCA1/2* genes encode large proteins with several discrete functional domains, and *BRCA1/2* proteins participate in multi-factorial complexes and signaling pathways, and the presence of stable truncated forms could cause interference with complex formation or function. In fact, a *BRCA1* null cell line, HCC1937, has been reported to express truncated *BRCA1* protein (Chen et al. 1998b), but our analyses of *BRCA1* null xenograft could not reveal the presence of truncated proteins (IV).

Gain-of-function mutations have been described for other TS genes, such as *p53* (Blandino et al. 1999), but mutations described have been mostly of missense type (reviewed in Sigal and Rotter 2000). One of the analyzed tumors contained missense *BRCA1* mutation (Cys61Gly), which gives rise to a full-length protein with a single amino acid substitution in the N-terminal RING domain (Wu et al. 1996). This particular tumor exhibited multiple copies of the mutant allele, but no relative copy number changes possibly suggesting a dominant negative role of this *BRCA1* mutant in tumorigenesis. Two-hybrid and co-immunoprecipitation studies have shown that Cys61Gly mutants fail to form *BRCA1*-*BARD1* complex (Wu et al. 1996), but *in vitro* characterization showed only local disturbances not affecting the complex formation (Brzovic et al. 2001). In conclusion, the presence of multiple copies of mutant *BRCA1/2* alleles in hereditary tumors may indicate an active role for mutant *BRCA1/2* in tumor development. Nevertheless, more samples and

## DISCUSSION

BRCA1/2 expression levels should be analyzed in hereditary tumors in order to specify the significance of the genetic re-arrangements detected in this study.

### **3. Concomitant loss of BRCA1 and BRCA2 (II)**

Only a few studies have addressed the question of combined loss of the *BRCA1/2* genes in hereditary breast cancer tumors. It has been reported that in sporadic breast cancer tumors combined LOH of *BRCA1* and *BRCA2* occurs at lower frequency than in hereditary *BRCA1*-linked breast tumors (Kelsell et al. 1996, Silva et al. 1999). In sporadic cancers, LOH/AI has been reported to occur frequently at either *BRCA1* or *BRCA2* locus (Hamann et al. 1996, van den Berg et al. 1996, Niederacher et al. 1997, Phelan et al. 1998). However, it is not totally clear whether AI only at a single *BRCA1/2* locus is prognostically significant in sporadic breast tumors (Beckmann et al. 1996, van den Berg et al. 1996, Bieche et al. 1997, Silva et al. 1999), but combined LOH at *BRCA1/2* loci has been significantly associated with an aggressive tumor phenotype (Silva et al. 1999).

The combined loss of both *BRCA1/2* genes was studied in hereditary BRCA1 and BRCA2 breast tumors and sporadic breast tumors by AI analysis and FISH. Combined AI at both *BRCA1/2* loci was frequent in hereditary tumors (73% in BRCA1 tumors, 67% in BRCA2 tumors). Physical deletions were detected less frequently, since AI resulted from other mechanisms besides deletions (I). When comparing hereditary tumors (both BRCA1 and BRCA2 tumors) to sporadic ones, the frequent combined loss of the *BRCA1/2* genes seemed to be related to hereditary form of breast cancer. Loss of both *BRCA1/2* genes was studied only by FISH in sporadic tumors, but we have shown that in these tumors AI and FISH results correlate well (I). However, one can speculate that the difference in methods could interfere with the interpretation of the results especially when the sample sizes were small. This fact must be taken into consideration when analyzing the results, which, however, were concordant with previously reported data that showed combined LOH at *BRCA1/2* loci in 32% (Silva et al. 1999) of sporadic tumors (our FISH results showed combined deletions in 29%).

It cannot be distinguished whether specifically *BRCA1/2* loci undergo inactivation or is the rate of AI increased at other loci as well in hereditary tumors. AI at other loci would have to be analyzed in order to determine the specificity of our findings. One could speculate that the observed difference between sporadic and hereditary tumors is due to chromosomal instability of *BRCA1/2*-mutation tumors. Nevertheless, our results raise the hypothetical question of why some breast tumors are selected for loss of both *BRCA1/2* genes. If both genes are involved in recombinational repair of DNA damage, one would expect that defect

in either gene would be sufficient for tumor formation. Recently, it was reported that three distinct breast cancer tumors derived from a double heterozygote patient (germ-line mutations in both *BRCA1* and *BRCA2* genes) showed biallelic inactivation of either *BRCA1* or *BRCA2*, but not both, suggesting functional equivalency of the *BRCA1/2* genes (Bell et al. 2002). However, it has been suggested that *BRCA1/2* genes function in distinct pathways, at least in DNA damage response (reviewed in Venkitaraman 2002). *BRCA2* may have a specific, direct role in double strand break repair by homologous recombination with *RAD51*, while *BRCA1* may act more globally in sensing and signaling the DNA damage response. Anyway, in the light of these distinct roles of the *BRCA1/2* genes, their concomitant loss would be expected to be even more harmful.

#### **4. Haplo-insufficiency of *BRCA1* in sporadic breast cancer (III)**

The central concept of Knudson's model in relation to TS gene inactivation is that loss of TS gene is recessive, i.e. both alleles need to be inactivated before tumor formation can occur. How are individuals carrying germ-line TS gene mutations, such as *BRCA1* mutations, then predisposed to cancer? Because these individuals already have one mutation (inherited germ-line mutation) in all their cells, predisposition is thought to result from the increased probability to acquire two mutations in a single cell. The intermediate step (from mutation of a single allele to clonal tumor expansion) could also be explained by selective advantage conferred by loss of one TS allele. In fact, some TS genes have been reported to show haplo-insufficiency for tumor suppression (Fero et al. 1998, Inoue et al. 2001, Yan et al. 2002). Inactivation of TS genes by epigenetic silencing can also extend the prevailing paradigm of TS genes (reviewed in Jones and Laird 1999). However, in respect to *BRCA1* gene in hereditary breast cancer, Knudson's theory seems to be relevant since tumors from germ-line *BRCA1* mutation carriers invariably exhibit loss of the wild-type allele. Since somatic *BRCA1* mutations have not been found (Futreal et al. 1994) but instead somatic re-arrangements and decreased expression have been frequently reported (Thompson et al. 1995, Niederacher et al. 1997, Phelan et al. 1998, Rio et al. 1998, Silva et al. 1999, Wilson et al. 1999), the haplo-insufficiency hypothesis (reviewed in Cook and McCaw 2000) could be relevant for the *BRCA1* gene in sporadic breast cancer. Due to the abundance of repetitive sequences, *BRCA1* gene has been suggested to frequently undergo somatic re-arrangements, such as deletions, in breast epithelial cells especially during rapid proliferation in puberty (reviewed in Welsh and King 2001). The haplo-insufficiency hypothesis suggests that inactivation of one allele (e.g. by deletion) could result in overall decrease in *BRCA1* mRNA and function, which in turn could increase the risk of additional cancer promoting mutations, especially under conditions of cellular stress induced by estrogen-mediated stimuli (reviewed in Welsh and King 2001). Based on the haplo-

## DISCUSSION

insufficiency hypothesis and our previous findings regarding *BRCA1* deletions (I), we studied the relationship of *BRCA1* deletions and gene expression in sporadic breast cancers in order to determine whether reduction in gene copy number affects mRNA levels or are the remaining *BRCA1* allele(s) sufficient for maintaining the expression. The impact of promoter hypermethylation on *BRCA1* expression was also studied.

*BRCA1* deletion was detected in almost half of the tumors studied, which is in concordance with previous data reporting LOH at *BRCA1* in approximately 50% of breast tumors (Sorlie et al. 1998, Silva et al. 1999, Hanby et al. 2000). *BRCA1* deletions associated with amplification of the *ErbB2* oncogene and aneuploidy, which are markers of aggressive breast cancer. Previous studies have also associated loss of *BRCA1* with high histological grade and hormone receptor negativity, both recognized as markers of aggressive tumor phenotype (Beckmann et al. 1996, Rio et al. 1998). An association between high *ErbB2* and low *BRCA1* expression has been previously reported (Yoshikawa et al. 1999), and, based on our findings, it may be due to genetic re-arrangements of both genes. A statistically highly significant association between *BRCA1* deletion (loss of gene copies) and low levels of full-length *BRCA1* mRNA was found. Our results are in line with studies using conventional RT-PCR (Ozcelik et al. 1998, Sourvinos and Spandidos 1998), which, have shown an association between LOH and decreased expression. However, conventional RT-PCR strategy can be compromised by problems of quantification. We used real-time quantitative RT-PCR, which allows quantification of the amount of mRNA based on determining the PCR cycle during which the reaction enters the exponential phase.

*BRCA1* deletions were mostly present in gene copy ratio 4:2 (four copies of chromosome 17 centromere and two copies of *BRCA1*), and less frequently of ratio 2:1 (two copies of chromosome 17 and one copy of *BRCA1*). No gene-dosage effect was seen, since tumors with 2:1 or 1:1 deletion of the *BRCA1* gene showed similar levels of full-length *BRCA1* mRNA when compared to tumors with *BRCA1* deletion of copy number ratio 4:2. Thus, the relative allelic loss as such seems to be more important than the absolute copy number in the regulation of *BRCA1* expression. This may indicate that physical deletion as such determines the low level of expression and reduplication of the genome does not have any additional effect.

Promoter hypermethylation was detected in only a small subset of tumors, as also reported by others (Catteau et al. 1999, Esteller et al. 2000). As previously shown (Magdinier et al. 1998, Rice et al. 1998, Catteau et al. 1999, Rice et al. 2000), *BRCA1* promoter hypermethylation was statistically significantly associated with low expression of full-length *BRCA1* mRNA. Thus, in a relatively small proportion of sporadic breast cancer

tumors epigenetic silencing (promoter hypermethylation) is likely to play a role in the regulation of BRCA1 expression. *BRCA1* deletions and promoter hypermethylation were not related indicating these two mechanisms to be rather independent of each other. However, three tumors showed both *BRCA1* deletion and promoter hypermethylation and they had significantly lower levels of full-length BRCA1 mRNA expression than tumors with either hypermethylation or deletion alone.

In multiple regression analysis, *BRCA1* deletion was the strongest determinant of low BRCA1 expression, followed by negative PgR status and promoter hypermethylation. Thus, the association of genetic and epigenetic mechanisms with down-regulation of full-length BRCA1 expression was independent of each other. Thus, these findings support the haplo-insufficiency hypothesis of *BRCA1* gene in sporadic breast cancer. The association of decreased BRCA1 expression with negative PgR status was revealed only in the regression model but not when individually tested, and could theoretically reflect the impact of a regulatory pathway.

The multiple regression model including *BRCA1* deletion, promoter hypermethylation and PgR status as significant factors explained ca. 45% of the total variation in BRCA1 mRNA expression. Therefore it seems likely that many other currently unknown mechanisms regulate the transcription of the *BRCA1* gene in sporadic breast cancer. BRCA1 expression may be down-regulated by a loss of proteins that positively regulate its expression or by an increase in negative regulatory proteins (reviewed in Welch and King 2001). Several of these regulatory proteins or cellular factors have been reported, such as dominant negative transcriptional regulator Id4 (Beger et al. 2001), Rb-E2F pathway (Wang et al. 2000a), the Brn-3b POU family transcription factor (Budhram-Mahadeo et al. 1999) and the GA binding protein  $\alpha/\beta$  (Atlas et al. 2000). Alternatively, BRCA1 expression may be inactivated in sporadic breast cancer by failure of post-translational phosphorylation events or by post-translational modifications in general (reviewed in Welch and King 2001). A detailed analysis of BRCA1 regulating proteins in sporadic breast cancer tumors could provide a rational line for future studies.

## DISCUSSION

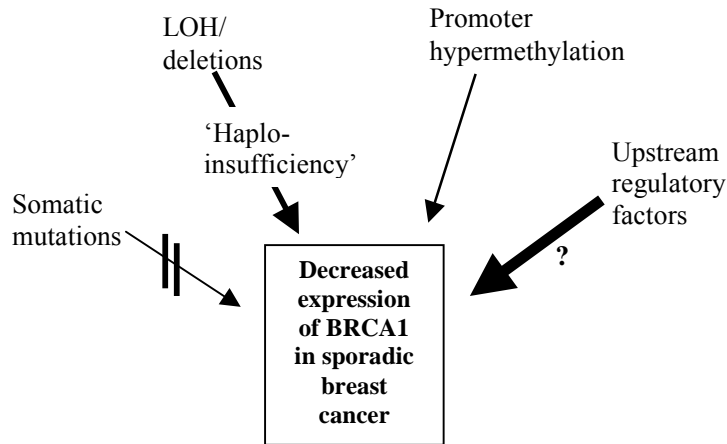

**Figure 13.** In the absence of somatic mutations, the suggested involvement of BRCA1 in sporadic breast cancer due to decrease in gene expression through various possible mechanisms.

With quantitative real-time RT-PCR strategy, it was possible to detect BRCA1 splice variants. We quantified the expression of BRCA1-delta11b splice variant mRNA (in which almost all of large exon 11 is spliced out), which is commonly expressed in normal tissues (Lu et al. 1996, Wilson et al. 1997) but its significance has remained somewhat unclear. Interestingly, BRCA1-delta11b lacks many important functional domains of BRCA1, such as the interaction site for DNA repair complex MRE11/RAD50/Nbs1 (Wang et al. 2000b) and for Importin  $\alpha$ , which takes part in BRCA1 nuclear transport (Chen et al. 1996). Based on the literature on BRCA1-delta11b and our previous study (I), which showed multiple copies of mutant *BRCA1* alleles in tumors with germ-line *BRCA1* mutation in exon 11, a working hypothesis was that BRCA1-delta11b expression could be up-regulated or there could be an inverse correlation between the expression levels of full-length and delta11b mRNA. However, the expression of BRCA1-delta11b was significantly lower in tumors with *BRCA1* deletion, and the expression levels of full-length mRNA (i.e. with intact exon 11) and delta11b variant were strongly correlated suggesting co-expression, which has been also previously reported (Wilson et al. 1997). It has been recently shown that BRCA1 N-terminal RING-domain also mediates BRCA1 nuclear localization by providing the binding site for BARD1, which, in turn, acts as chaperone for BRCA1 nuclear entry (Fabbro et al. 2002). In fact, BRCA1-delta11b has been reported to localize both to nucleus and cytoplasm (Wilson et al. 1997, Chai et al. 1999, Huber et al. 2001, Fabbro et al. 2002). Thus, even in the absence of NLS, BRCA1-delta11b can enter the cell nucleus and form DNA damage-inducible foci almost identical to full-length BRCA1 (Huber et al. 2001, Fabbro et al. 2002). The strong correlation between full-length and delta-11b isoforms suggests that both forms might be functionally important in sporadic breast cancer, and



haplo-insufficiency applies for them both. On the other hand, the co-expression of full-length and delta11b mRNA may just as well suggest that alternative splicing of delta11b may not be under active regulation but merely reflecting the expression levels of the full-length form or that the regulation of BRCA1-delta11b may take place at translational level.

### **5. Characterization of BRCA1 null xenograft and cell line (IV)**

We have established a breast cancer xenograft and cell line derived from a breast cancer axillary node metastasis of a *BRCA1* germ-line mutation carrier. The cells are hemizygous for *BRCA1* having only the mutant allele present due to monosomy of chromosome 17. The germ-line *BRCA1* mutation (1806C→T) leads to a premature stop codon and termination of translation at amino acid 563, prior to the nuclear localization sequences and the proposed interaction site for MRE11/RAD50/Nbs1 complex, as well as the BRCT and transactivation domains (reviewed in Venkitaraman 2002). Recently, however, it has been reported that BRCA1 N-terminal RING domain also mediates BRCA1 nuclear entry (Fabbro et al. 2002). Thus, if expressed, the truncated BRCA1 protein might still be nuclear but lose some or most of its functions in DNA repair and transactivation. Alternatively, BRCA1 splice variant (BRCA1-delta11b), lacking most of exon 11 including the truncating mutation of the xenograft and cell line (1806C→T), would theoretically, if escaped from nonsense-mediated mRNA decay prior to translation, allow expression of a shorter BRCA1 protein, that retains the N- and C-terminal epitopes recognized by the antibodies used in this study. However, despite the expression of full-length BRCA1 and BRCA1-delta11b mRNAs, no BRCA1 proteins by immunoprecipitation or western blotting were detected in xenograft cells, although the presence of protein products at levels below detection limits cannot be excluded. The antibodies used in this study are well-documented and widely used in many studies (Wilson et al. 1999) but still they produced unspecific bands suggesting that BRCA1 antibodies are still hampered by specificity problems (Wilson et al. 1996). It is possible that, if truncated proteins were translated, they would have been too unstable and therefore could not have been detected even if mRNAs were discovered. The previously defined BRCA1 null cell line, HCC1937 (Tomlinson et al. 1998), actually expresses low levels of truncated BRCA1 protein (Chen et al. 1998b), which can, at least in theory, interfere with the interpretation of experimental studies introducing ectopic expression of the wild-type BRCA1 or mutant forms of BRCA1 in the cell line.

The L56Br-X1 xenograft and L56Br-C1 cell line showed complex karyotypes, aneuploidy and many chromosomal changes detected by CGH, which all are typical for *BRCA1* mutation induced tumorigenesis (Breast Cancer Linkage Consortium 1997, Johannsson et al. 1997, Tirkkonen et al. 1997b). The xenograft was negative for ER, PR, HER-2, and

## DISCUSSION

xenograft and cell line were positive for *p53* mutation, all of which are hallmarks of BRCA1 tumors (Breast Cancer Linkage Consortium 1997). Despite the extensive genetic instability, the L56Br-X1 xenograft and L56Br-C1 cell line have retained resemblance to parental tumors with regard to the genotype and tumor biological features during their establishment and progression. Gene expression profiling data further supported this, since different xenograft generations, cell line and the parental tumors (primary and metastasis) resembled closest to each other having retained similar expression patterns. Thus, the xenograft showed the specific features that associate with BRCA1 mutation tumors. The expression data further indicated that the cell line had remained stable during its evolution by showing similar expression as parental tumor tissues.

## Conclusions

AI at *BRCA1* and *BRCA2* was detected in almost all breast tumors from germ-line *BRCA1* and *BRCA2* mutation carriers, respectively. These results are concordant with previously reported data and support the role of the *BRCA1/2* genes as tumor suppressors. The specific aim of our study was to analyze the mechanisms resulting in AI at *BRCA1/2* loci both in hereditary and sporadic breast cancers. AI at *BRCA1/2* loci in hereditary breast tumors from germ-line *BRCA1* mutation carriers resulted not only from physical deletions but also from other mechanisms, such as non-disjunction and somatic recombination, whereas AI at *BRCA1/2* loci in sporadic tumors resulted predominantly from physical deletions. These results suggest that specific pathways, such as recombinational repair, may be defective in *BRCA1* breast tumors. Multiple mutant copies were detected especially in the case of *BRCA1* gene in hereditary *BRCA1* tumors, which might suggest a dominant negative function. Combined loss of *BRCA1* and *BRCA2* gene copies was more common in hereditary than in sporadic breast cancers.

Physical deletion of the *BRCA1* gene was frequently detected in sporadic breast tumors and it associated independently with decreased expression of both full-length *BRCA1* mRNA and *BRCA1*-delta11b splice variant mRNA. This, in turn, suggests that *BRCA1* may be involved in sporadic breast cancer due to haplo-insufficiency. *BRCA1* gene was down-regulated in sporadic breast cancers also by promoter hypermethylation in a small proportion of tumors. Multiple regression analysis indicated that almost half of the variation in *BRCA1* expression levels in sporadic breast cancer tumors could be explained by changes in *BRCA1* gene copy number and epigenetic regulation.

Strong correlation between the expression levels of *BRCA1* full-length and delta11b splice variant mRNA was detected suggesting that these two forms may be actively co-expressed. On the other hand this may indicate that *BRCA1*-delta11b levels are not under active regulation and may just reflect the expression levels of full-length *BRCA1*, or that the regulation of *BRCA1*-delta11b expression may take place at translational level. Alternatively, the strong correlation can suggest that both forms (full-length and delta11b) may have tumor suppressor functions.

L56Br-X1 xenograft and L56Br-C1 cell line mimic *BRCA1*-associated breast cancer *in vivo*. They constitute useful experimental model systems for studies on *BRCA1* function, as well as the pathogenesis and treatment of human breast cancer induced by loss of the *BRCA1* gene.

## **Acknowledgements**

This study was carried out in the Laboratory of Cancer Biology, Institute of Medical Technology, University of Tampere and Tampere University Hospital during the years 1997-2003.

I express sincere thanks to my supervisor and our research group leader Professor Jorma Isola M.D., Ph.D. for giving me the opportunity to join his research group in order to start and finally complete this research project. I also want to express warm thanks to my supervisor Docent Minna Tanner, M.D., Ph.D. for guidance and continuous support. I thank both my supervisors for showing interest in my work and having such a positive and encouraging attitude towards my project that I wish to continue scientific work after dissertation. Thank you both!

I also want to thank Docent Timo Koivula M.D., Ph.D., the Head of Department of Clinical Chemistry, Tampere University Hospital, Professor Olli Silvennoinen M.D., Ph.D., the Head of the Institute of Medical Technology, University of Tampere for providing research facilities for this study. I also want to thank Professor Kalle Saksela, M.D., Ph.D., the Head of Tampere Graduate School in Biomedicine and Biotechnology, University of Tampere for offering the graduate school position for completion of this work.

I want to thank Docent Heli Nevanlinna, Ph.D., University of Helsinki and Docent Anne Kallioniemi, M.D., Ph.D., University of Tampere for carefully reviewing the manuscript. Their critical notes and comments improved this manuscript considerably.

I wish to thank all my co-authors and collaborators but especially I thank Professor Åke Borg, Ph.D., University of Lund for the valuable hereditary breast tumor samples, for outstanding collaboration and for all the time that he has put to this study, and also Doctor Oskar Johannsson, M.D., Ph.D., University Hospital of Reykjavik for excellent collaboration.

I want to thank all the friends and colleagues at the 'old' Laboratory of Cancer Genetics, where I have started this study. I have such nice memories from those days; thank you all! I want to thank all the members of our Journal Club as well as the club's tutor Docent Anne Kallioniemi, M.D., Ph.D., for interesting and inspiring scientific conversations.

## ACKNOWLEDGEMENTS

I express my warm thanks to everyone in our research group of Cancer Biology for creating such a friendly and hearty atmosphere. It has been a pleasure to work (and travel) with you all! Mrs. Arja Alkula, Mrs. Anne Luuri, Mrs. Sari Toivola, Mrs. Mariitta Vakkuri, and Ms. Päivi Järvinen are all thanked not only for their excellent laboratory skills but also for being such amicable co-workers. I also want to thank Ms. Ulla Saarela and Anita Kapanen, Ph.D. for friendly collaboration.

I want to thank all my friends in all parts of Finland for their friendship and support during these years. I express my gratitude to my family, especially to my mother Kyllikki and my father Erkki, for having always believed in me.

The publishers of the original communications are cordially thanked for their permission to reproduce the papers in this manuscript.

Finally, Olli is thanked for everything.

This study was financially supported by the Medical Research Fund of Tampere University Hospital, the Finnish Medical Research Fund Duodecim, the Pirkanmaa Cancer Society, the Satakunta Cultural Foundation, the Emil Aaltonen Foundation, the Research Fund of Tampere University, the Finnish Cancer Society, the Finnish Breast Cancer Group and the Science Fund of Tampere City.

Tampere, April 2003

Synnöve Staff

## REFERENCES

## References

- Agnarsson BA, Jonasson JG, Bjornsdottir IB, Barkardottir RB, Egilsson V and Sigurdsson H (1998): Inherited BRCA2 mutation associated with high grade breast cancer. *Breast Cancer Res Treat*, 47:121-7.
- Albertsen HM, Smith SA, Mazoyer S, Fujimoto E, Stevens J, Williams B, Rodriguez P, Cropp CS, Slijepcevic P, Carlson M, Robertson M, Bradley P, Lawrence E, Harrington T, Sheng ZM, Hoopes R, Sternberg N, Brothman A, Callahan R, Ponder BAJ and White RL (1994): A physical map and candidate genes in the BRCA1 region on chromosome 17q12-21. *Nat Genet*, 7:472-9.
- Anderson SF, Schlegel BP, Nakajima T, Wolpin ES and Parvin JD (1998): BRCA1 protein is linked to the RNA polymerase II holoenzyme complex via RNA helicase A. *Nat Genet*, 19:254-6.
- Ansquer Y, Gautier C, Fourquet A, Asselain B and Stoppa-Lyonnet D (1998): Survival in early-onset BRCA1 breast-cancer patients. Institut Curie Breast Cancer Group. *Lancet*, 352:541.
- Antoniou AC, Pharoah PD, McMullan G, Day NE, Ponder BA and Easton D (2001): Evidence for further breast cancer susceptibility genes in addition to BRCA1 and BRCA2 in a population-based study. *Genet Epidemiol*, 21:1-18.
- Antoniou AC, Pharoah PD, McMullan G, Day NE, Stratton MR, Peto J, Ponder BJ and Easton DF (2002): A comprehensive model for familial breast cancer incorporating BRCA1, BRCA2 and other genes. *Br J Cancer*, 86:76-83.
- Armes JE, Trute L, White D, Southey MC, Hammet F, Tesoriero A, Hutchins AM, Dite GS, McCredie MR, Giles GG, Hopper JL and Venter DJ (1999): Distinct molecular pathogenesis of early-onset breast cancers in BRCA1 and BRCA2 mutation carriers: a population-based study. *Cancer Res*, 59:2011-7.
- Atlas E, Stramwasser M, Whiskin K and Mueller CR (2000): GA-binding protein alpha/beta is a critical regulator of the BRCA1 promoter. *Oncogene*, 19:1933-40.
- Bachelier R, Vincent A, Mathevet P, Magdinier F, Lenoir GM and Frappart L (2002): Retroviral transduction of splice variant Brca1-Delta11 or mutant Brca1-W1777Stop causes mouse epithelial mammary atypical duct hyperplasia. *Virchows Arch*, 440:261-6.
- Baumann P and West SC (1998): Role of the human RAD51 protein in homologous recombination and double-stranded-break repair. *Trends Biochem Sci*, 23:247-51.
- Beckmann MW, Niederacher D, Schnurch HG, Gusterson BA and Bender HG (1997): Multistep carcinogenesis of breast cancer and tumour heterogeneity. *J Mol Med*, 75:429-39.
- Beckmann MW, Picard F, An HX, van Roeyen CR, Dominik SI, Mosny DS, Schnurch HG, Bender HG and Niederacher D (1996): Clinical impact of detection of loss of heterozygosity of BRCA1 and BRCA2 markers in sporadic breast cancer. *Br J Cancer*, 73:1220-6.
- Beger C, Pierce LN, Kruger M, Marcusson EG, Robbins JM, Welch P, Welch K, King MC, Barber JR and Wong-Staal F (2001): Identification of Id4 as a regulator of BRCA1 expression by using a ribozyme-library-based inverse genomics approach. *Proc Natl Acad Sci U S A*, 98:130-5.
- Bell DW, Erban J, Sgroi DC and Haber DA (2002): Selective loss of heterozygosity in multiple breast cancers from a carrier of mutations in both BRCA1 and BRCA2. *Cancer Res*, 62:2741-3.
- Bernard-Gallon D, Peffault De Latour M, Rio P, Favy D, Hizel C, Vissac C and Bignon YJ (2000): BRCA2 protein expression in sporadic breast carcinoma with or without allelic loss of BRCA2. *Int J Cancer*, 86:453-6.
- Bernard-Gallon DJ, De Latour MP, Rio PG, Penault-Llorca FM, Favy DA, Hizel C, Chassagne J and Bignon YJ (1999): Subcellular localization of BRCA1 protein in sporadic breast carcinoma with or without allelic loss of BRCA1 gene. *Int J Oncol*, 14:653-61.
- Bertwistle D, Swift S, Marston NJ, Jackson LE, Crossland S, Crompton MR, Marshall CJ and Ashworth A (1997): Nuclear location and cell cycle regulation of the BRCA2 protein. *Cancer Res*, 57:5485-8.
- Bieche I, Nogues C and Lidereau R (1999): Overexpression of BRCA2 gene in sporadic breast tumours. *Oncogene*, 18:5232-8.
- Bieche I, Nogues C, Rivoilan S, Khodja A, Latil A and Lidereau R (1997): Prognostic value of loss of heterozygosity at BRCA2 in human breast carcinoma. *Br J Cancer*, 76:1416-8.
- Blandino G, Levine AJ and Oren M (1999): Mutant p53 gain of function: differential effects of different p53 mutants on resistance of cultured cells to chemotherapy. *Oncogene*, 18:477-85.
- Boardman LA, Thibodeau SN, Schaid DJ, Lindor NM, McDonnell SK, Burgart LJ, Ahlquist DA, Podratz KC, Pittelkow M and Hartmann LC (1998): Increased risk for cancer in patients with the Peutz-Jeghers syndrome. *Ann Intern Med*, 128:896-9.

## REFERENCES

- Bochar DA, Wang L, Beniya H, Kinev A, Xue Y, Lane WS, Wang W, Kashanchi F and Shiekhattar R (2000): BRCA1 is associated with a human SWI/SNF-related complex: linking chromatin remodeling to breast cancer. *Cell*, 102:257-65.
- Borg Å, Baldetorp B, Ferno M, Killander D, Olsson H and Sigurdsson H (1991): ERBB2 amplification in breast cancer with a high rate of proliferation. *Oncogene*, 6:137-43.
- Borg Å, Zhang QX, Johannsson O and Olsson H (1994): High frequency of allelic imbalance at the BRCA1 region on chromosome 17q in both familial and sporadic ductal breast carcinomas. *J Natl Cancer Inst*, 86:792-4.
- Bos JL, Fearon ER, Hamilton SR, Verlaan-de Vries M, van Boom JH, van der Eb AJ and Vogelstein B (1987): Prevalence of ras gene mutations in human colorectal cancers. *Nature*, 327:293-7.
- Breast Cancer Linkage Consortium (1997): Pathology of familial breast cancer: differences between breast cancers in carriers of BRCA1 or BRCA2 mutations and sporadic cases. *Breast Cancer Linkage Consortium. Lancet*, 349:1505-10.
- Breast Cancer Linkage Consortium (1999): Cancer risks in BRCA2 mutation carriers. *The Breast Cancer Linkage Consortium. J Natl Cancer Inst*, 91:1310-6.
- Brodie SG, Xu X, Qiao W, Li WM, Cao L and Deng CX (2001): Multiple genetic changes are associated with mammary tumorigenesis in Brca1 conditional knockout mice. *Oncogene*, 20:7514-23.
- Brose MS, Rebbeck TR, Calzone KA, Stopfer JE, Nathanson KL and Weber BL (2002): Cancer risk estimates for BRCA1 mutation carriers identified in a risk evaluation program. *J Natl Cancer Inst*, 94:1365-72.
- Brzovic PS, Rajagopal P, Hoyt DW, King MC and Klevit RE (2001): Structure of a BRCA1-BARD1 heterodimeric RING-RING complex. *Nat Struct Biol*, 8:833-7.
- Budhram-Mahadeo V, Ndisang D, Ward T, Weber BL and Latchman DS (1999): The Brn-3b POU family transcription factor represses expression of the BRCA-1 anti-oncogene in breast cancer cells. *Oncogene*, 18:6684-91.
- Byers PH (2002): Killing the messenger: new insights into nonsense-mediated mRNA decay. *J Clin Invest*, 109:3-6.
- Callebaut I and Mornon JP (1997): From BRCA1 to RAP1: a widespread BRCT module closely associated with DNA repair. *FEBS Lett*, 400:25-30.
- Cantor SB, Bell DW, Ganesan S, Kass EM, Drapkin R, Grossman S, Wahrer DC, Sgroi DC, Lane WS, Haber DA and Livingston DM (2001): BACH1, a novel helicase-like protein, interacts directly with BRCA1 and contributes to its DNA repair function. *Cell*, 105:149-60.
- Catteau A, Harris WH, Xu CF and Solomon E (1999): Methylation of the BRCA1 promoter region in sporadic breast and ovarian cancer: correlation with disease characteristics. *Oncogene*, 18:1957-65.
- Cavenee WK, Dryja TP, Phillips RA, Benedict WF, Godbout R, Gallie BL, Murphree AL, Strong LC and White RL (1983): Expression of recessive alleles by chromosomal mechanisms in retinoblastoma. *Nature*, 305:779-84.
- Cavenee WK, Hansen MF, Nordenskjold M, Kock E, Maumenee I, Squire JA, Phillips RA and Gallie BL (1985): Genetic origin of mutations predisposing to retinoblastoma. *Science*, 228:501-3.
- Cavenee WK, Koufos A and Hansen MF (1986): Recessive mutant genes predisposing to human cancer. *Mutat Res*, 168:3-14.
- Chai YL, Cui J, Shao N, Shyam E, Reddy P and Rao VN (1999): The second BRCT domain of BRCA1 proteins interacts with p53 and stimulates transcription from the p21WAF1/CIP1 promoter. *Oncogene*, 18:263-8.
- Chapman MS and Verma IM (1996): Transcriptional activation by BRCA1. *Nature*, 382:678-9.
- Chappuis PO, Rosenblatt J and Foulkes WD (1999): The influence of familial and hereditary factors on the prognosis of breast cancer. *Ann Oncol*, 10:1163-70.
- Chen C and Kolodner RD (1999): Gross chromosomal rearrangements in *Saccharomyces cerevisiae* replication and recombination defective mutants. *Nat Genet*, 23:81-5.
- Chen C, Umezu K and Kolodner RD (1998a): Chromosomal rearrangements occur in *S. cerevisiae* rfa1 mutator mutants due to mutagenic lesions processed by double-strand-break repair. *Mol Cell*, 2:9-22.
- Chen J, Silver DP, Walpita D, Cantor SB, Gazdar AF, Tomlinson G, Couch FJ, Weber BL, Ashley T, Livingston DM and Scully R (1998b): Stable interaction between the products of the BRCA1 and BRCA2 tumor suppressor genes in mitotic and meiotic cells. *Mol Cell*, 2:317-28.
- Chen JJ, Silver D, Cantor S, Livingston DM and Scully R (1999): BRCA1, BRCA2, and Rad51 operate in a common DNA damage response pathway. *Cancer Res*, 59:1752s-1756s.
- Chen PL, Chen CF, Chen Y, Xiao J, Sharp ZD and Lee WH (1998c): The BRC repeats in BRCA2 are critical for RAD51 binding and resistance to methyl methanesulfonate treatment. *Proc Natl Acad Sci U S A*, 95:5287-92.

## REFERENCES

- Chen Y, Farmer AA, Chen CF, Jones DC, Chen PL and Lee WH (1996): BRCA1 is a 220-kDa nuclear phosphoprotein that is expressed and phosphorylated in a cell cycle-dependent manner. *Cancer Res*, 56:3168-72.
- Claus EB, Risch N and Thompson WD (1991): Genetic analysis of breast cancer in the cancer and steroid hormone study. *Am J Hum Genet*, 48:232-42.
- Collins N, McManus R, Wooster R, Mangion J, Seal S, Lakhani SR, Ormiston W, Daly PA, Ford D, Easton DF and Stratton MR (1995): Consistent loss of the wild type allele in breast cancers from a family linked to the BRCA2 gene on chromosome 13q12-13. *Oncogene*, 10:1673-5.
- Collins N, Wooster R and Stratton MR (1997): Absence of methylation of CpG dinucleotides within the promoter of the breast cancer susceptibility gene BRCA2 in normal tissues and in breast and ovarian cancers. *Br J Cancer*, 76:1150-6.
- Connor F, Bertwistle D, Mee PJ, Ross GM, Swift S, Grigorieva E, Tybulewicz VL and Ashworth A (1997): Tumorigenesis and a DNA repair defect in mice with a truncating Brca2 mutation. *Nat Genet*, 17:423-30.
- Cook WD and McCaw BJ (2000): Accommodating haploinsufficient tumor suppressor genes in Knudson's model. *Oncogene*, 19:3434-8.
- Cortez D, Wang Y, Qin J and Elledge SJ (1999): Requirement of ATM-dependent phosphorylation of brca1 in the DNA damage response to double-strand breaks. *Science*, 286:1162-6.
- Couch FJ and Weber BL (1996): Mutations and polymorphisms in the familial early-onset breast cancer (BRCA1) gene. *Breast Cancer Information Core. Hum Mutat*, 8:8-18.
- Crook T, Brooks LA, Crossland S, Osin P, Barker KT, Waller J, Philip E, Smith PD, Yulug I, Peto J, Parker G, Allday MJ, Crompton MR and Gusterson BA (1998): p53 mutation with frequent novel condons but not a mutator phenotype in BRCA1- and BRCA2-associated breast tumours. *Oncogene*, 17:1681-9.
- Davies AA, Masson JY, McIlwraith MJ, Stasiak AZ, Stasiak A, Venkitaraman AR and West SC (2001): Role of BRCA2 in control of the RAD51 recombination and DNA repair protein. *Mol Cell*, 7:273-82.
- Deng CX and Scott F (2000): Role of the tumor suppressor gene Brca1 in genetic stability and mammary gland tumor formation. *Oncogene*, 19:1059-64.
- Dennis C (1999): Branching out with BRCA1. *Nat Genet*, 22:10.
- Devilee P and Cornelisse CJ (1994): Somatic genetic changes in human breast cancer. *Biochim Biophys Acta*, 1198:113-30.
- Easton DF, Ford D and Bishop DT (1995): Breast and ovarian cancer incidence in BRCA1-mutation carriers. *Breast Cancer Linkage Consortium. Am J Hum Genet*, 56:265-71.
- Easton DF, Narod SA, Ford D and Steel M (1994): The genetic epidemiology of BRCA1. *Breast Cancer Linkage Consortium. Lancet*, 344:761.
- Eerola H, Pukkala E, Pyrhönen S, Blomqvist C, Sankila R and Nevanlinna H (2001a): Risk of cancer in BRCA1 and BRCA2 mutation-positive and -negative breast cancer families (Finland). *Cancer Causes Control*, 12:739-46.
- Eerola H, Vahteristo P, Sarantaus L, Kyyrönen P, Pyrhönen S, Blomqvist C, Pukkala E, Nevanlinna H and Sankila R (2001b): Survival of breast cancer patients in BRCA1, BRCA2, and non-BRCA1/2 breast cancer families: a relative survival analysis from Finland. *Int J Cancer*, 93:368-72.
- Egawa C, Miyoshi Y, Taguchi T, Tamaki Y and Noguchi S (2001a): Quantitative analysis of BRCA1 and BRCA2 mRNA expression in sporadic breast carcinomas and its relationship with clinicopathological characteristics. *Jpn J Cancer Res*, 92:624-30.
- Egawa C, Miyoshi Y, Taguchi T, Tamaki Y and Noguchi S (2002): High BRCA2 mRNA expression predicts poor prognosis in breast cancer patients. *Int J Cancer*, 98:879-82.
- Egawa C, Miyoshi Y, Takamura Y, Taguchi T, Tamaki Y and Noguchi S (2001b): Decreased expression of BRCA2 mRNA predicts favorable response to docetaxel in breast cancer. *Int J Cancer*, 95:255-9.
- Eisinger F, Jacquemier J, Charpin C, Stoppa-Lyonnet D, Bressac-de Paillerets B, Peyrat JP, Longy M, Guinebretiere JM, Sauvan R, Noguchi T, Birnbaum D and Sobol H (1998): Mutations at BRCA1: the medullary breast carcinoma revisited. *Cancer Res*, 58:1588-92.
- Ellisen LW and Haber DA (1998): Hereditary breast cancer. *Annu Rev Med*, 49:425-36.
- Esteller M (2002): CpG island hypermethylation and tumor suppressor genes: a booming present, a brighter future. *Oncogene*, 21:5427-40.
- Esteller M, Silva JM, Dominguez G, Bonilla F, Matias-Guiu X, Lerma E, Bussaglia E, Prat J, Harkes IC, Repasky EA, Gabrielson E, Schutte M, Baylin SB and Herman JG (2000): Promoter hypermethylation and BRCA1 inactivation in sporadic breast and ovarian tumors. *J Natl Cancer Inst*, 92:564-9.



## REFERENCES

- Fabbro M, Rodriguez JA, Baer R and Henderson BR (2002): BARD1 induces BRCA1 intranuclear foci formation by increasing RING-dependent BRCA1 nuclear import and inhibiting BRCA1 nuclear export. *J Biol Chem*, 277:21315-24.
- Fan S, Ma YX, Wang C, Yuan RQ, Meng Q, Wang JA, Erdos M, Goldberg ID, Webb P, Kushner PJ, Pestell RG and Rosen EM (2001a): Role of direct interaction in BRCA1 inhibition of estrogen receptor activity. *Oncogene*, 20:77-87.
- Fan S, Wang J, Yuan R, Ma Y, Meng Q, Erdos MR, Pestell RG, Yuan F, Auburn KJ, Goldberg ID and Rosen EM (1999): BRCA1 inhibition of estrogen receptor signaling in transfected cells. *Science*, 284:1354-6.
- Fan S, Yuan R, Ma YX, Meng Q, Goldberg ID and Rosen EM (2001b): Mutant BRCA1 genes antagonize phenotype of wild-type BRCA1. *Oncogene*, 20:8215-35.
- Fearon ER and Vogelstein B (1990): A genetic model for colorectal tumorigenesis. *Cell*, 61:759-67.
- Feigelson HS and Henderson BE (1996): Estrogens and breast cancer. *Carcinogenesis*, 17:2279-84.
- Fero ML, Randel E, Gurley KE, Roberts JM and Kemp CJ (1998): The murine gene p27Kip1 is haplo-insufficient for tumour suppression. *Nature*, 396:177-80.
- Finnish Cancer Registry (2000): Cancer Incidence in Finland 2000. Cancer Statistics of the National Research and Development Center for Welfare and Health. Cancer Statistics at [www.cancerregistry.fi](http://www.cancerregistry.fi).
- Fodde R (2002): The APC gene in colorectal cancer. *Eur J Cancer*, 38:867-71.
- Fodor FH, Weston A, Bleiweiss IJ, McCurdy LD, Walsh MM, Tartter PI, Brower ST and Eng CM (1998): Frequency and carrier risk associated with common BRCA1 and BRCA2 mutations in Ashkenazi Jewish breast cancer patients. *Am J Hum Genet*, 63:45-51.
- Ford D, Easton DF, Bishop DT, Narod SA and Goldgar DE (1994): Risks of cancer in BRCA1-mutation carriers. *Breast Cancer Linkage Consortium. Lancet*, 343:692-5.
- Ford D, Easton DF, Stratton M, Narod S, Goldgar D, Devilee P, Bishop DT, Weber B, Lenoir G, Chang-Claude J, Sobol H, Teare MD, Struwing J, Arason A, Scherneck S, Peto J, Rebbeck TR, Tonin P, Neuhausen S, Barkardottir R, Eyfjord J, Lynch H, Ponder BA, Gayther SA and Zelada-Hedman M (1998): Genetic heterogeneity and penetrance analysis of the BRCA1 and BRCA2 genes in breast cancer families. The Breast Cancer Linkage Consortium. *Am J Hum Genet*, 62:676-89.
- Foulkes WD, Wong N, Brunet JS, Begin LR, Zhang JC, Martinez JJ, Rozen F, Tonin PN, Narod SA, Karp SE and Pollak MN (1997): Germ-line BRCA1 mutation is an adverse prognostic factor in Ashkenazi Jewish women with breast cancer. *Clin Cancer Res*, 3:2465-9.
- Friedman LS, Thistlethwaite FC, Patel KJ, Yu VP, Lee H, Venkitaraman AR, Abel KJ, Carlton MB, Hunter SM, Colledge WH, Evans MJ and Ponder BA (1998): Thymic lymphomas in mice with a truncating mutation in Brca2. *Cancer Res*, 58:1338-43.
- Fuks F, Milner J and Kouzarides T (1998): BRCA2 associates with acetyltransferase activity when bound to P/CAF. *Oncogene*, 17:2531-4.
- Futreal PA, Liu Q, Shattuck-Eidens D, Cochran C, Harshman K, Tavtigian S, Bennett LM, Haugen-Strano A, Swensen J, Miki Y, Eddington K, McClure M, Frye C, Weaver-Feldhaus J, Ding W, Gholami Z, Söderkvist P, Terry L, Jhanwar S, Berchuck A, Iglehart JD, Marks J, Ballinger DG, Barrett JC, Skolnick MH, Kamb A and Wiseman R (1994): BRCA1 mutations in primary breast and ovarian carcinomas. *Science*, 266:120-2.
- Ganesan S, Silver DP, Greenberg RA, Avni D, Drapkin R, Miron A, Mok SC, Randrianarison V, Brodie S, Salstrom J, Rasmussen TP, Klimke A, Marrese C, Marahrens Y, Deng CX, Feunteun J and Livingston DM (2002): BRCA1 supports XIST RNA concentration on the inactive X chromosome. *Cell*, 111:393-405.
- Gentile M, Olsen K, Dufmats M and Wingren S (1999): Frequent allelic losses at 11q24.1-q25 in young women with breast cancer: association with poor survival. *Br J Cancer*, 80:843-9.
- Goggins M, Schutte M, Lu J, Moskaluk CA, Weinstein CL, Petersen GM, Yeo CJ, Jackson CE, Lynch HT, Hruban RH and Kern SE (1996): Germline BRCA2 gene mutations in patients with apparently sporadic pancreatic carcinomas. *Cancer Res*, 56:5360-4.
- Gonzalez R, Silva JM, Dominguez G, Garcia JM, Martinez G, Vargas J, Provencio M, Espana P and Bonilla F (1999): Detection of loss of heterozygosity at RAD51, RAD52, RAD54 and BRCA1 and BRCA2 loci in breast cancer: pathological correlations. *Br J Cancer*, 81:503-9.
- Gowen LC, Avrutskaya AV, Latour AM, Koller BH and Leadon SA (1998): BRCA1 required for transcription-coupled repair of oxidative DNA damage. *Science*, 281:1009-12.
- Gretarsdottir S, Thorlacius S, Valgardsdottir R, Gudlaugsdottir S, Sigurdsson S, Steinarsdottir M, Jonasson JG, Anamthawat-Jonsson K and Eyfjord JE (1998): BRCA2 and p53 mutations in primary breast cancer in relation to genetic instability. *Cancer Res*, 58:859-62.

## REFERENCES

- Grushko TA, Blackwood MA, Schumm PL, Hagos FG, Adeyanju MO, Feldman MD, Sanders MO, Weber BL and Olopade OI (2002): Molecular-cytogenetic analysis of HER-2/neu gene in BRCA1-associated breast cancers. *Cancer Res*, 62:1481-8.
- Gudas JM, Li T, Nguyen H, Jensen D, Rauscher FJ, 3rd and Cowan KH (1996): Cell cycle regulation of BRCA1 messenger RNA in human breast epithelial cells. *Cell Growth Differ*, 7:717-23.
- Gudmundsson J, Johannesdottir G, Bergthorsson JT, Arason A, Ingvarsson S, Egilsson V and Barkardottir RB (1995): Different tumor types from BRCA2 carriers show wild-type chromosome deletions on 13q12-q13. *Cancer Res*, 55:4830-2.
- Gyapay G, Morissette J, Vignal A, Dib C, Fizames C, Millasseau P, Marc S, Bernardi G, Lathrop M and Weissenbach J (1994): The 1993-94 Genethon human genetic linkage map. *Nat Genet*, 7:246-339.
- Hahn WC, Counter CM, Lundberg AS, Beijersbergen RL, Brooks MW and Weinberg RA (1999): Creation of human tumour cells with defined genetic elements. *Nature*, 400:464-8.
- Hakansson S, Johannsson O, Johansson U, Sellberg G, Loman N, Gerdes AM, Holmberg E, Dahl N, Pandis N, Kristofferson U, Olsson H and Borg A (1997): Moderate frequency of BRCA1 and BRCA2 germ-line mutations in Scandinavian familial breast cancer. *Am J Hum Genet*, 60:1068-78.
- Hamann U, Herbold C, Costa S, Solomayer EF, Kaufmann M, Bastert G, Ulmer HU, Frenzel H and Komitowski D (1996): Allelic imbalance on chromosome 13q: evidence for the involvement of BRCA2 and RB1 in sporadic breast cancer. *Cancer Res*, 56:1988-90.
- Hamann U and Sinn HP (2000): Survival and tumor characteristics of German hereditary breast cancer patients. *Breast Cancer Res Treat*, 59:185-92.
- Hanahan D and Weinberg RA (2000): The hallmarks of cancer. *Cell*, 100:57-70.
- Hanby AM, Kelsell DP, Potts HW, Gillett CE, Bishop DT, Spurr NK and Barnes DM (2000): Association between loss of heterozygosity of BRCA1 and BRCA2 and morphological attributes of sporadic breast cancer. *Int J Cancer*, 88:204-8.
- Harkin DP, Bean JM, Miklos D, Song YH, Truong VB, Englert C, Christians FC, Ellisen LW, Maheswaran S, Oliner JD and Haber DA (1999): Induction of GADD45 and JNK/SAPK-dependent apoptosis following inducible expression of BRCA1. *Cell*, 97:575-86.
- Harris H, Miller OJ, Klein G, Worst P and Tachibana T (1969): Suppression of malignancy by cell fusion. *Nature*, 223:363-8.
- Hashizume R, Fukuda M, Maeda I, Nishikawa H, Oyake D, Yabuki Y, Ogata H and Ohta T (2001): The RING heterodimer BRCA1-BARD1 is a ubiquitin ligase inactivated by a breast cancer-derived mutation. *J Biol Chem*, 276:14537-40.
- Hedenfalk I, Duggan D, Chen Y, Radmacher M, Bittner M, Simon R, Meltzer P, Gusterson B, Esteller M, Kallioniemi OP, Wilfond B, Borg A and Trent J (2001): Gene-expression profiles in hereditary breast cancer. *N Engl J Med*, 344:539-48.
- Hedenfalk IA (2002): Gene expression profiling of hereditary and sporadic ovarian cancers reveals unique BRCA1 and BRCA2 signatures. *J Natl Cancer Inst*, 94:960-1.
- Hegardt C, Johannsson OT and Oredsson SM (2002): Rapid caspase-dependent cell death in cultured human breast cancer cells induced by the polyamine analogue N(1),N(11)-diethylnorspermine. *Eur J Biochem*, 269:1033-9.
- Helin HJ, Helle MJ, Kallioniemi OP and Isola JJ (1989): Immunohistochemical determination of estrogen and progesterone receptors in human breast carcinoma. Correlation with histopathology and DNA flow cytometry. *Cancer*, 63:1761-7.
- Henderson IC (1993): Risk factors for breast cancer development. *Cancer*, 71:2127-40.
- Henson DE and Tarone RE (1994): Involution and the etiology of breast cancer. *Cancer*, 74:424-9.
- Herman JG, Graff JR, Myohanen S, Nelkin BD and Baylin SB (1996): Methylation-specific PCR: a novel PCR assay for methylation status of CpG islands. *Proc Natl Acad Sci U S A*, 93:9821-6.
- Hilakivi-Clarke L (2000): Estrogens, BRCA1, and breast cancer. *Cancer Res*, 60:4993-5001.
- Huber LJ, Yang TW, Sarkisian CJ, Master SR, Deng CX and Chodosh LA (2001): Impaired DNA damage response in cells expressing an exon 11-deleted murine Brcal variant that localizes to nuclear foci. *Mol Cell Biol*, 21:4005-15.
- Huusko P, Pääkkönen K, Launonen V, Pöyhönen M, Blanco G, Kauppila A, Puistola U, Kiviniemi H, Kujala M, Leisti J and Winqvist R (1998): Evidence of founder mutations in Finnish BRCA1 and BRCA2 families. *Am J Hum Genet*, 62:1544-8.
- Hwang A, Maity A, McKenna WG and Muschel RJ (1995): Cell cycle-dependent regulation of the cyclin B1 promoter. *J Biol Chem*, 270:28419-24.
- Ingvarsson S (1999): Molecular genetics of breast cancer progression. *Semin Cancer Biol*, 9:277-88.
- Ingvarsson S, Geirsdottir EK, Johannesdottir G, Sigbjornsdottir BI, Eiriksdottir G, Ragnarsson G, Agnarsson BA, Gudmundsson J, Jonasson JG, Sigurdsson A, Egilsson V and Barkardottir RB (1998): High

## REFERENCES

- incidence of loss of heterozygosity in breast tumors from carriers of the BRCA2 999del5 mutation. *Cancer Res*, 58:4421-5.
- Inoue K, Zindy F, Randle DH, Rehg JE and Sherr CJ (2001): Dmp1 is haplo-insufficient for tumor suppression and modifies the frequencies of Arf and p53 mutations in Myc-induced lymphomas. *Genes Dev*, 15:2934-9.
- Ioannou PA, Amemiya CT, Garnes J, Kroisel PM, Shizuya H, Chen C, Batzer MA and de Jong PJ (1994): A new bacteriophage P1-derived vector for the propagation of large human DNA fragments. *Nat Genet*, 6:84-9.
- Jensen DE, Proctor M, Marquis ST, Gardner HP, Ha SI, Chodosh LA, Ishov AM, Tommerup N, Vissing H, Sekido Y, Minna J, Borodovsky A, Schultz DC, Wilkinson KD, Maul GG, Barlev N, Berger SL, Prendergast GC and Rauscher FJ, 3rd (1998): BAP1: a novel ubiquitin hydrolase which binds to the BRCA1 RING finger and enhances BRCA1-mediated cell growth suppression. *Oncogene*, 16:1097-112.
- Johannsson O, Ostermeyer EA, Håkansson S, Friedman LS, Johannsson U, Sellberg G, Brondum-Nielsen K, Sele V, Olsson H, King MC and Borg Å (1996): Founding BRCA1 mutations in hereditary breast and ovarian cancer in southern Sweden. *Am J Hum Genet*, 58:441-50.
- Johannsson OT, Idvall I, Anderson C, Borg Å, Barkardottir RB, Egilsson V and Olsson H (1997): Tumour biological features of BRCA1-induced breast and ovarian cancer. *Eur J Cancer*, 33:362-71.
- Johannsson OT, Ranstam J, Borg A and Olsson H (1998a): Survival of BRCA1 breast and ovarian cancer patients: a population-based study from southern Sweden. *J Clin Oncol*, 16:397-404.
- Johannsson OT, Ranstam J, Borg Å and Olsson H (1998b): Survival of BRCA1 breast and ovarian cancer patients: a population-based study from southern Sweden. *J Clin Oncol*, 16:397-404.
- Jones PA and Laird PW (1999): Cancer epigenetics comes of age. *Nat Genet*, 21:163-7.
- Kainu T, Kononen J, Johannsson O, Olsson H, Borg Å and Isola J (1996): Detection of germline BRCA1 mutations in breast cancer patients by quantitative messenger RNA in situ hybridization. *Cancer Res*, 56:2912-5.
- Kallioniemi OP, Kallioniemi A, Piper J, Isola J, Waldman FM, Gray JW and Pinkel D (1994): Optimizing comparative genomic hybridization for analysis of DNA sequence copy number changes in solid tumors. *Genes Chromosomes Cancer*, 10:231-43.
- Karp SE, Tonin PN, Begin LR, Martinez JJ, Zhang JC, Pollak MN and Foulkes WD (1997): Influence of BRCA1 mutations on nuclear grade and estrogen receptor status of breast carcinoma in Ashkenazi Jewish women. *Cancer*, 80:435-41.
- Katsama A, Sourvinos G, Zachos G and Spandidos DA (2000): Allelic loss at the BRCA1, BRCA2 and TP53 loci in human sporadic breast carcinoma. *Cancer Lett*, 150:165-70.
- Kauraniemi P, Hedenfalk I, Persson K, Duggan DJ, Tanner M, Johannsson O, Olsson H, Trent JM, Isola J and Borg Å (2000): MYB oncogene amplification in hereditary BRCA1 breast cancer. *Cancer Res*, 60:5323-8.
- Kelsell DP, Spurr NK, Barnes DM, Gusterson B and Bishop DT (1996): Combined loss of BRCA1/BRCA2 in grade 3 breast carcinomas. *Lancet*, 347:1554-5.
- Kemkemer R, Schrank S, Vogel W, Gruler H and Kaufmann D (2002): Increased noise as an effect of haploinsufficiency of the tumor-suppressor gene neurofibromatosis type 1 in vitro. *Proc Natl Acad Sci U S A*, 99:13783-8.
- Kerangueven F, Eisinger F, Noguchi T, Allione F, Wargniez V, Eng C, Padberg G, Theillet C, Jacquemier J, Longy M, Sobol H and Birnbaum D (1997): Loss of heterozygosity in human breast carcinomas in the ataxia telangiectasia, Cowden disease and BRCA1 gene regions. *Oncogene*, 14:339-47.
- Khanna KK and Jackson SP (2001): DNA double-strand breaks: signaling, repair and the cancer connection. *Nat Genet*, 27:247-54.
- Kinzler KW and Vogelstein B (1997): Cancer-susceptibility genes. Gatekeepers and caretakers. *Nature*, 386:761, 763.
- Kleiman FE and Manley JL (1999): Functional interaction of BRCA1-associated BARD1 with polyadenylation factor CstF-50. *Science*, 285:1576-9.
- Knudson AG, Jr. (1971): Mutation and cancer: statistical study of retinoblastoma. *Proc Natl Acad Sci U S A*, 68:820-3.
- Koonin EV, Altschul SF and Bork P (1996): BRCA1 protein products ... Functional motifs. *Nat Genet*, 13:266-8.
- Lakhani SR, Jacquemier J, Sloane JP, Gusterson BA, Anderson TJ, van de Vijver MJ, Farid LM, Venter D, Antoniou A, Storer-Isser A, Smyth E, Steel CM, Haites N, Scott RJ, Goldgar D, Neuhausen S, Daly PA, Ormiston W, McManus R, Scherneck S, Ponder BA, Ford D, Peto J, Stoppa-Lyonnet D, Bignon YJ, Struwing JP, Spurr NK, Bishop DT, Klijn JGM, Devilee P, Cornelisse CJ, C. L, Lenoir G, Barkardottir RB, Egilsson V, Hamann U, Chang-Claude J, Sobol H, Weber B, Stratton MR and

## REFERENCES

- Easton DF (1998): Multifactorial analysis of differences between sporadic breast cancers and cancers involving BRCA1 and BRCA2 mutations. *J Natl Cancer Inst*, 90:1138-45.
- Lancaster JM, Wooster R, Mangion J, Phelan CM, Cochran C, Gumbs C, Seal S, Barfoot R, Collins N, Bignell G, Patel S, Hamoudi R, Larsson C, Wiseman RW, Berchuck A, Iglehart JD, Marks JR, Ashworth A, Stratton MR and Futreal PA (1996): BRCA2 mutations in primary breast and ovarian cancers. *Nat Genet*, 13:238-40.
- Land H, Parada LF and Weinberg RA (1983): Tumorigenic conversion of primary embryo fibroblasts requires at least two cooperating oncogenes. *Nature*, 304:596-602.
- Lee JS, Collins KM, Brown AL, Lee CH and Chung JH (2000): hCds1-mediated phosphorylation of BRCA1 regulates the DNA damage response. *Nature*, 404:201-4.
- Lee JS, Wacholder S, Struewing JP, McAdams M, Pee D, Brody LC, Tucker MA and Hartge P (1999a): Survival after breast cancer in Ashkenazi Jewish BRCA1 and BRCA2 mutation carriers. *J Natl Cancer Inst*, 91:259-63.
- Lee WY, Jin YT, Chang TW, Lin PW and Su IJ (1999b): Immunolocalization of BRCA1 protein in normal breast tissue and sporadic invasive ductal carcinomas: a correlation with other biological parameters. *Histopathology*, 34:106-12.
- Levine AJ (1993): The tumor suppressor genes. *Annu Rev Biochem*, 62:623-51.
- Li S, Chen PL, Subramanian T, Chinnadurai G, Tomlinson G, Osborne CK, Sharp ZD and Lee WH (1999): Binding of CtIP to the BRCT repeats of BRCA1 involved in the transcription regulation of p21 is disrupted upon DNA damage. *J Biol Chem*, 274:11334-8.
- Li S, Ting NS, Zheng L, Chen PL, Ziv Y, Shiloh Y, Lee EY and Lee WH (2000): Functional link of BRCA1 and ataxia telangiectasia gene product in DNA damage response. *Nature*, 406:210-5.
- Liaw D, Marsh DJ, Li J, Dahia PL, Wang SI, Zheng Z, Bose S, Call KM, Tsou HC, Peacocke M, Eng C and Parsons R (1997): Germline mutations of the PTEN gene in Cowden disease, an inherited breast and thyroid cancer syndrome. *Nat Genet*, 16:64-7.
- Liehr JG (2000): Is estradiol a genotoxic mutagenic carcinogen? *Endocr Rev*, 21:40-54.
- Liu HX, Cartegni L, Zhang MQ and Krainer AR (2001): A mechanism for exon skipping caused by nonsense or missense mutations in BRCA1 and other genes. *Nat Genet*, 27:55-8.
- Liu Y and West SC (2002): Distinct functions of BRCA1 and BRCA2 in double-strand break repair. *Breast Cancer Res*, 4:9-13.
- Loman N, Johannsson O, Bendahl P, Dahl N, Einbeigi Z, Gerdes A, Borg A and Olsson H (2000): Prognosis and clinical presentation of BRCA2-associated breast cancer. *Eur J Cancer*, 36:1365-73.
- Loman N, Johannsson O, Bendahl PO, Borg A, Ferno M and Olsson H (1998): Steroid receptors in hereditary breast carcinomas associated with BRCA1 or BRCA2 mutations or unknown susceptibility genes. *Cancer*, 83:310-9.
- Loman N, Johannsson O, Kristofferson U, Olsson H and Borg A (2001): Family history of breast and ovarian cancers and BRCA1 and BRCA2 mutations in a population-based series of early-onset breast cancer. *J Natl Cancer Inst*, 93:1215-23.
- Lu M, Conzen SD, Cole CN and Arrick BA (1996): Characterization of functional messenger RNA splice variants of BRCA1 expressed in nonmalignant and tumor-derived breast cells. *Cancer Res*, 56:4578-81.
- Ludwig T, Chapman DL, Papaioannou VE and Efstratiadis A (1997): Targeted mutations of breast cancer susceptibility gene homologs in mice: lethal phenotypes of *Brca1*, *Brca2*, *Brca1/Brca2*, *Brca1/p53*, and *Brca2/p53* nullizygous embryos. *Genes Dev*, 11:1226-41.
- Ludwig T, Fisher P, Ganesan S and Efstratiadis A (2001): Tumorigenesis in mice carrying a truncating *Brca1* mutation. *Genes Dev*, 15:1188-93.
- Luo G, Santoro IM, McDaniel LD, Nishijima I, Mills M, Youssoufian H, Vogel H, Schultz RA and Bradley A (2000): Cancer predisposition caused by elevated mitotic recombination in Bloom mice. *Nat Genet*, 26:424-9.
- Lynch BJ, Holden JA, Buys SS, Neuhausen SL and Gaffney DK (1998): Pathobiologic characteristics of hereditary breast cancer. *Hum Pathol*, 29:1140-4.
- Lynch HT, Albano WA, Danes BS, Layton MA, Kimberling WJ, Lynch JF, Cheng SC, Costello KA, Mulcahy GM, Wagner CA and et al. (1984): Genetic predisposition to breast cancer. *Cancer*, 53:612-22.
- Lynch HT, Marcus JM, Watson P, Conway T, Fitzsimmons ML and Lynch JF (1989). Genetic epidemiology of breast cancer. In: *Genetic epidemiology of cancer*, pp. 289-332. Eds. T Hirayamas, Boca Raton, Florida.
- Macleod K (2000): Tumor suppressor genes. *Curr Opin Genet Dev*, 10:81-93.

## REFERENCES

- Magdinier F, Ribieras S, Lenoir GM, Frappart L and Dante R (1998): Down-regulation of BRCA1 in human sporadic breast cancer; analysis of DNA methylation patterns of the putative promoter region. *Oncogene*, 17:3169-76.
- Malkin D, Li FP, Strong LC, Fraumeni JF, Jr., Nelson CE, Kim DH, Kassel J, Gryka MA, Bischoff FZ, Tainsky MA and Friend SH (1990): Germ line p53 mutations in a familial syndrome of breast cancer, sarcomas, and other neoplasms. *Science*, 250:1233-8.
- Marcus JN, Watson P, Page DL, Narod SA, Lenoir GM, Tonin P, Linder-Stephenson L, Salerno G, Conway TA and Lynch HT (1996): Hereditary breast cancer: pathobiology, prognosis, and BRCA1 and BRCA2 gene linkage. *Cancer*, 77:697-709.
- Marcus JN, Watson P, Page DL, Narod SA, Tonin P, Lenoir GM, Serova O and Lynch HT (1997): BRCA2 hereditary breast cancer pathophenotype. *Breast Cancer Res Treat*, 44:275-7.
- Mazoyer S, Puget N, Perrin-Vidoz L, Lynch HT, Serova-Sinilnikova OM and Lenoir GM (1998): A BRCA1 nonsense mutation causes exon skipping. *Am J Hum Genet*, 62:713-5.
- Meijers-Heijboer H, van den Ouweland A, Klijn J, Wasielewski M, de Snoo A, Oldenburg R, Hollestelle A, Houben M, Crepin E, van Veghel-Plandsoen M, Elstrodt F, van Duijn C, Bartels C, Meijers C, Schutte M, McGuffog L, Thompson D, Easton D, Sodha N, Seal S, Barfoot R, Mangion J, Chang-Claude J, Eccles D, Eeles R, Evans DG, Houlston R, Murday V, Narod S, Peretz T, Peto J, Phelan C, Zhang HX, Szabo C, Devilee P, Goldgar D, Futreal PA, Nathanson KL, Weber B, Rahman N and Stratton MR (2002): Low-penetrance susceptibility to breast cancer due to CHEK2(\*)1100delC in noncarriers of BRCA1 or BRCA2 mutations. *Nat Genet*, 31:55-9.
- Meuth M (1990): The structure of mutation in mammalian cells. *Biochim Biophys Acta*, 1032:1-17.
- Miki Y, Katagiri T, Kasumi F, Yoshimoto T and Nakamura Y (1996): Mutation analysis in the BRCA2 gene in primary breast cancers. *Nat Genet*, 13:245-7.
- Miki Y, Swensen J, Shattuck-Eidens D, Futreal PA, Harshman K, Tavtigian S, Liu Q, Cochran C, Bennett LM, Ding W, Bell R, Rosenthal J, Hussey C, Tran T, McClure M, Frye C, Hattier T, Phelps R, Haugen-Strano A, Katcher H, Yakumo K, Gholami Z, Shaffer D, Stone S, Bayer S, Wray C, Bodgen R, Dayananth P, Ward J, Tonin P, Narod S, Bristow PK, Norris FH, Helvering L, Morrison P, Rosteck P, Lai M, Barrett JC, Lewis C, Neuhausen S, Cannon-Albright L, Goldgar D, Wiseman R, Kamb A and Skolnick MH (1994): A strong candidate for the breast and ovarian cancer susceptibility gene BRCA1. *Science*, 266:66-71.
- Milner J, Ponder B, Hughes-Davies L, Seltmann M and Kouzarides T (1997): Transcriptional activation functions in BRCA2. *Nature*, 386:772-3.
- Moynahan ME, Chiu JW, Koller BH and Jasin M (1999): Brca1 controls homology-directed DNA repair. *Mol Cell*, 4:511-8.
- Moynahan ME, Pierce AJ and Jasin M (2001): BRCA2 is required for homology-directed repair of chromosomal breaks. *Mol Cell*, 7:263-72.
- Murthy SK, DiFrancesco LM, Ogilvie RT and Demetrick DJ (2002): Loss of heterozygosity associated with uniparental disomy in breast carcinoma. *Mod Pathol*, 15:1241-50.
- Nathanson KL and Weber BL (2001): "Other" breast cancer susceptibility genes: searching for more holy grail. *Hum Mol Genet*, 10:715-20.
- Neuhausen SL and Marshall CJ (1994): Loss of heterozygosity in familial tumors from three BRCA1-linked kindreds. *Cancer Res*, 54:6069-72.
- Niederacher D, Picard F, van Roeyen C, An HX, Bender HG and Beckmann MW (1997): Patterns of allelic loss on chromosome 17 in sporadic breast carcinomas detected by fluorescent-labeled microsatellite analysis. *Genes Chromosomes Cancer*, 18:181-92.
- Niwa Y, Oyama T and Nakajima T (2000): BRCA1 expression status in relation to DNA methylation of the BRCA1 promoter region in sporadic breast cancers. *Jpn J Cancer Res*, 91:519-26.
- Noguchi S, Kasugai T, Miki Y, Fukutomi T, Emi M and Nomizu T (1999): Clinicopathologic analysis of BRCA1- or BRCA2-associated hereditary breast carcinoma in Japanese women. *Cancer*, 85:2200-5.
- Nordling M, Karlsson P, Wahlstrom J, Engwall Y, Wallgren A and Martinsson T (1998): A large deletion disrupts the exon 3 transcription activation domain of the BRCA2 gene in a breast/ovarian cancer family. *Cancer Res*, 58:1372-5.
- Olsen JH, Hahnemann JM, Borresen-Dale AL, Brondum-Nielsen K, Hammarstrom L, Kleinerman R, Kaariainen H, Lonnqvist T, Sankila R, Seersholm N, Tretli S, Yuen J, Boice JD, Jr. and Tucker M (2001): Cancer in patients with ataxia-telangiectasia and in their relatives in the nordic countries. *J Natl Cancer Inst*, 93:121-7.
- Orban TI and Olah E (2001): Expression profiles of BRCA1 splice variants in asynchronous and in G1/S synchronized tumor cell lines. *Biochem Biophys Res Commun*, 280:32-8.
- Ozcelik H, To MD, Couture J, Bull SB and Andrulis IL (1998): Preferential allelic expression can lead to reduced expression of BRCA1 in sporadic breast cancers. *Int J Cancer*, 77:1-6.

## REFERENCES

- Pao GM, Janknecht R, Ruffner H, Hunter T and Verma IM (2000): CBP/p300 interact with and function as transcriptional coactivators of BRCA1. *Proc Natl Acad Sci U S A*, 97:1020-5.
- Park JJ, Irvine RA, Buchanan G, Koh SS, Park JM, Tilley WD, Stallcup MR, Press MF and Coetzee GA (2000): Breast cancer susceptibility gene 1 (BRCA1) is a coactivator of the androgen receptor. *Cancer Res*, 60:5946-9.
- Patel KJ, Yu VP, Lee H, Corcoran A, Thistlethwaite FC, Evans MJ, Colledge WH, Friedman LS, Ponder BA and Venkitaraman AR (1998): Involvement of Brca2 in DNA repair. *Mol Cell*, 1:347-57.
- Paull TT, Rogakou EP, Yamazaki V, Kirchgessner CU, Gellert M and Bonner WM (2000): A critical role for histone H2AX in recruitment of repair factors to nuclear foci after DNA damage. *Curr Biol*, 10:886-95.
- Perrin-Vidoz L, Sinilnikova OM, Stoppa-Lyonnet D, Lenoir GM and Mazoyer S (2002): The nonsense-mediated mRNA decay pathway triggers degradation of most BRCA1 mRNAs bearing premature termination codons. *Hum Mol Genet*, 11:2805-14.
- Peto J, Collins N, Barfoot R, Seal S, Warren W, Rahman N, Easton DF, Evans C, Deacon J and Stratton MR (1999): Prevalence of BRCA1 and BRCA2 gene mutations in patients with early-onset breast cancer. *J Natl Cancer Inst*, 91:943-9.
- Pharoah PD, Day NE, Duffy S, Easton DF and Ponder BA (1997): Family history and the risk of breast cancer: a systematic review and meta-analysis. *Int J Cancer*, 71:800-9.
- Phelan CM, Borg A, Cuny M, Crichton DN, Balderson T, Andersen TI, Caligo MA, Lidereau R, Lindblom A, Seitz S, Kelsell D, Hamann U, Rio P, Thorlacius S, Papp J, Olah E, Ponder B, Bignon YJ, Scherneck S, Barkardottir R, Borresen-Dale AL, Eyfjord J, Theillet C, Thompson AM and Larsson C (1998): Consortium study on 1280 breast carcinomas: allelic loss on chromosome 17 targets subregions associated with family history and clinical parameters. *Cancer Res*, 58:1004-12.
- Querzoli P, Albonico G, di Iasio MG, Ferretti S, Rinaldi R, Cariello A, Pedriali M, Matteuzzi M, Maestri I and Nenci I (2001): Biophenotypes and survival of BRCA1 and TP53 deleted breast cancer in young women. *Breast Cancer Res Treat*, 66:135-42.
- Quon KC and Berns A (2001): Haplo-insufficiency? Let me count the ways. *Genes Dev*, 15:2917-21.
- Rajan JV, Marquis ST, Gardner HP and Chodosh LA (1997): Developmental expression of Brca2 colocalizes with Brca1 and is associated with proliferation and differentiation in multiple tissues. *Dev Biol*, 184:385-401.
- Rajan JV, Wang M, Marquis ST and Chodosh LA (1996): Brca2 is coordinately regulated with Brca1 during proliferation and differentiation in mammary epithelial cells. *Proc Natl Acad Sci U S A*, 93:13078-83.
- Rebbeck TR (1999): Inherited genetic predisposition in breast cancer. A population-based perspective. *Cancer*, 86:2493-501.
- Rebbeck TR, Kantoff PW, Krithivas K, Neuhausen S, Blackwood MA, Godwin AK, Daly MB, Narod SA, Garber JE, Lynch HT, Weber BL and Brown M (1999): Modification of BRCA1-associated breast cancer risk by the polymorphic androgen-receptor CAG repeat. *Am J Hum Genet*, 64:1371-7.
- Rennstam K, Baldetorp B, Kytölä S, Tanner M and Isola J (2001): Chromosomal rearrangements and oncogene amplification precede aneuploidization in the genetic evolution of breast cancer. *Cancer Res*, 61:1214-9.
- Rice JC, Massey-Brown KS and Futscher BW (1998): Aberrant methylation of the BRCA1 CpG island promoter is associated with decreased BRCA1 mRNA in sporadic breast cancer cells. *Oncogene*, 17:1807-12.
- Rice JC, Ozcelik H, Maxeiner P, Andrulis I and Futscher BW (2000): Methylation of the BRCA1 promoter is associated with decreased BRCA1 mRNA levels in clinical breast cancer specimens. *Carcinogenesis*, 21:1761-5.
- Rio PG, Maurizis JC, Peffault de Latour M, Bignon YJ and Bernard-Gallon DJ (1999): Quantification of BRCA1 protein in sporadic breast carcinoma with or without loss of heterozygosity of the BRCA1 gene. *Int J Cancer*, 80:823-6.
- Rio PG, Pernin D, Bay JO, Albuisson E, Kwiatkowski F, De Latour M, Bernard-Gallon DJ and Bignon YJ (1998): Loss of heterozygosity of BRCA1, BRCA2 and ATM genes in sporadic invasive ductal breast carcinoma. *Int J Oncol*, 13:849-53.
- Roa BB, Boyd AA, Volcik K and Richards CS (1996): Ashkenazi Jewish population frequencies for common mutations in BRCA1 and BRCA2. *Nat Genet*, 14:185-7.
- Robson M, Gilewski T, Haas B, Levin D, Borgen P, Rajan P, Hirschaut Y, Pressman P, Rosen PP, Lesser ML, Norton L and Offit K (1998): BRCA-associated breast cancer in young women. *J Clin Oncol*, 16:1642-9.

## REFERENCES

- Rummukainen JK, Salminen T, Lundin J, Joensuu H and Isola JJ (2001): Amplification of c-myc oncogene by chromogenic and fluorescence in situ hybridization in archival breast cancer tissue array samples. *Lab Invest*, 81:1545-51.
- Saal LH, Troein C, Vallon-Christersson J, Gruvberger S, Borg A and Peterson C (2002): BioArray Software Environment (BASE): a platform for comprehensive management and analysis of microarray data. *Genome Biol*, 3:SOFTWARE0003.
- Schmutzler RK, Bierhoff E, Werkhausen T, Fimmers R, Speiser P, Kubista E, Krebs D, Zeillinger R, Wiestler OD and Von Deimling A (1997): Genomic deletions in the BRCA1, BRCA2 and TP53 regions associate with low expression of the estrogen receptor in sporadic breast carcinoma. *Int J Cancer*, 74:322-5.
- Schubert EL, Lee MK, Mefford HC, Argonza RH, Morrow JE, Hull J, Dann JL and King MC (1997): BRCA2 in American families with four or more cases of breast or ovarian cancer: recurrent and novel mutations, variable expression, penetrance, and the possibility of families whose cancer is not attributable to BRCA1 or BRCA2. *Am J Hum Genet*, 60:1031-40.
- Schwab M (1998): Amplification of oncogenes in human cancer cells. *Bioessays*, 20:473-9.
- Scully R, Anderson SF, Chao DM, Wei W, Ye L, Young RA, Livingston DM and Parvin JD (1997a): BRCA1 is a component of the RNA polymerase II holoenzyme. *Proc Natl Acad Sci U S A*, 94:5605-10.
- Scully R, Chen J, Ochs RL, Keegan K, Hoekstra M, Feunteun J and Livingston DM (1997b): Dynamic changes of BRCA1 subnuclear location and phosphorylation state are initiated by DNA damage. *Cell*, 90:425-35.
- Scully R, Chen J, Plug A, Xiao Y, Weaver D, Feunteun J, Ashley T and Livingston DM (1997c): Association of BRCA1 with Rad51 in mitotic and meiotic cells. *Cell*, 88:265-75.
- Seery LT, Knowlden JM, Gee JM, Robertson JF, Kenny FS, Ellis IO and Nicholson RI (1999): BRCA1 expression levels predict distant metastasis of sporadic breast cancers. *Int J Cancer*, 84:258-62.
- Seger YR, Garcia-Cao M, Piccinin S, Cunsolo CL, Doglioni C, Blasco MA, Hannon GJ and Maestro R (2002): Transformation of normal human cells in the absence of telomerase activation. *Cancer Cell*, 2:401-13.
- Serova OM, Mazoyer S, Puget N, Dubois V, Tonin P, Shugart YY, Goldgar D, Narod SA, Lynch HT and Lenoir GM (1997): Mutations in BRCA1 and BRCA2 in breast cancer families: are there more breast cancer-susceptibility genes? *Am J Hum Genet*, 60:486-95.
- Sharan SK, Morimatsu M, Albrecht U, Lim DS, Regel E, Dinh C, Sands A, Eichele G, Hasty P and Bradley A (1997): Embryonic lethality and radiation hypersensitivity mediated by Rad51 in mice lacking Brca2. *Nature*, 386:804-10.
- Shtivelman E, Lifshitz B, Gale RP and Canaani E (1985): Fused transcript of abl and bcr genes in chronic myelogenous leukaemia. *Nature*, 315:550-4.
- Sigal A and Rotter V (2000): Oncogenic mutations of the p53 tumor suppressor: the demons of the guardian of the genome. *Cancer Res*, 60:6788-93.
- Silva JM, Gonzalez R, Provencio M, Dominguez G, Garcia JM, Gallego I, Palacios J, Espana P and Bonilla F (1999): Loss of heterozygosity in BRCA1 and BRCA2 markers and high-grade malignancy in breast cancer. *Breast Cancer Res Treat*, 53:9-17.
- Smith SA, Easton DF, Evans DG and Ponder BA (1992): Allele losses in the region 17q12-21 in familial breast and ovarian cancer involve the wild-type chromosome. *Nat Genet*, 2:128-31.
- Snouwaert JN, Gowen LC, Latour AM, Mohn AR, Xiao A, DiBiase L and Koller BH (1999): BRCA1 deficient embryonic stem cells display a decreased homologous recombination frequency and an increased frequency of non-homologous recombination that is corrected by expression of a brca1 transgene. *Oncogene*, 18:7900-7.
- Sorlie T, Andersen TI, Bukholm I and Borresen-Dale AL (1998): Mutation screening of BRCA1 using PTT and LOH analysis at 17q21 in breast carcinomas from familial and non-familial cases. *Breast Cancer Res Treat*, 48:259-64.
- Sourvinos G and Spandidos DA (1998): Decreased BRCA1 expression levels may arrest the cell cycle through activation of p53 checkpoint in human sporadic breast tumors. *Biochem Biophys Res Commun*, 245:75-80.
- Stahl A, Levy N, Wadzynska T, Sussan JM, Jourdan-Fonta D and Saracco JB (1994): The genetics of retinoblastoma. *Ann Genet*, 37:172-8.
- Stanbridge EJ (1990): Human tumor suppressor genes. *Annu Rev Genet*, 24:615-57.
- Stokke T, Collins C, Kuo WL, Kowbel D, Shadravan F, Tanner M, Kallioniemi A, Kallioniemi OP, Pinkel D, Deaven L and Gray JW (1995): A physical map of chromosome 20 established using fluorescence in situ hybridization and digital image analysis. *Genomics*, 26:134-7.

## REFERENCES

- Struewing JP, Hartge P, Wacholder S, Baker SM, Berlin M, McAdams M, Timmerman MM, Brody LC and Tucker MA (1997): The risk of cancer associated with specific mutations of BRCA1 and BRCA2 among Ashkenazi Jews. *N Engl J Med*, 336:1401-8.
- Suzuki Y, Orita M, Shiraishi M, Hayashi K and Sekiya T (1990): Detection of ras gene mutations in human lung cancers by single-strand conformation polymorphism analysis of polymerase chain reaction products. *Oncogene*, 5:1037-43.
- Syrjäkoski K, Vahteristo P, Eerola H, Tamminen A, Kivinummi K, Sarantaus L, Holli K, Blomqvist C, Kallioniemi OP, Kainu T and Nevanlinna H (2000): Population-based study of BRCA1 and BRCA2 mutations in 1035 unselected Finnish breast cancer patients. *J Natl Cancer Inst*, 92:1529-31.
- Tanner M, Järvinen P and Isola J (2001): Amplification of HER-2/neu and topoisomerase IIalpha in primary and metastatic breast cancer. *Cancer Res*, 61:5345-8.
- Tanner MM, Karhu RA, Nupponen NN, Borg Å, Baldetorp B, Pejovic T, Ferno M, Killander D and Isola JJ (1998): Genetic aberrations in hypodiploid breast cancer: frequent loss of chromosome 4 and amplification of cyclin D1 oncogene. *Am J Pathol*, 153:191-9.
- Taub R, Kirsch I, Morton C, Lenoir G, Swan D, Tronick S, Aaronson S and Leder P (1982): Translocation of the c-myc gene into the immunoglobulin heavy chain locus in human Burkitt lymphoma and murine plasmacytoma cells. *Proc Natl Acad Sci U S A*, 79:7837-41.
- Tavtigian SV, Simard J, Rommens J, Couch F, Shattuck-Eidens D, Neuhausen S, Merajver S, Thorlacius S, Offit K, Stoppa-Lyonnet D, Belanger C, Bell R, Berry S, Bogden R, Chen Q, Davis T, Dumont M, Frye C, Hattier T, Jammulapati S, Janecki T, Jiang P, Kehrer R, Leblanc JF, J.T. M, McArthur-Morrison J, Nguyen K, Peng Y, Samson C, Schroeder M, Snyder SC, Steele L, Stringfellow M, Stroup C, Swedlund B, Swensen J, Teng D, Thomas A, Tran T, Tranchant M, Weaver-Feldhaus J, Wong AKC, Shizuya H, Eyfjord JE, Cannon-Albright L, Labrie F, Skolnick MH, Weber B, Kamb A and Goldgar DE (1996): The complete BRCA2 gene and mutations in chromosome 13q-linked kindreds. *Nat Genet*, 12:333-7.
- Taylor J, Lymboura M, Pace PE, A'Hern R P, Desai AJ, Shousha S, Coombes RC and Ali S (1998): An important role for BRCA1 in breast cancer progression is indicated by its loss in a large proportion of non-familial breast cancers. *Int J Cancer*, 79:334-42.
- Teng DH, Bogden R, Mitchell J, Baumgard M, Bell R, Berry S, Davis T, Ha PC, Kehrer R, Jammulapati S, Chen Q, Offit K, Skolnick MH, Tavtigian SV, Jhanwar S, Swedlund B, Wong AK and Kamb A (1996): Low incidence of BRCA2 mutations in breast carcinoma and other cancers. *Nat Genet*, 13:241-4.
- Thai TH, Du F, Tsan JT, Jin Y, Phung A, Spillman MA, Massa HF, Muller CY, Ashfaq R, Mathis JM, Miller DS, Trask BJ, Baer R and Bowcock AM (1998): Mutations in the BRCA1-associated RING domain (BARD1) gene in primary breast, ovarian and uterine cancers. *Hum Mol Genet*, 7:195-202.
- Thompson D and Easton D (2001): Variation in cancer risks, by mutation position, in BRCA2 mutation carriers. *Am J Hum Genet*, 68:410-9.
- Thompson D and Easton D (2002a): Variation in BRCA1 cancer risks by mutation position. *Cancer Epidemiol Biomarkers Prev*, 11:329-36.
- Thompson D and Easton DF (2002b): Cancer Incidence in BRCA1 mutation carriers. *J Natl Cancer Inst*, 94:1358-65.
- Thompson ME, Jensen RA, Obermiller PS, Page DL and Holt JT (1995): Decreased expression of BRCA1 accelerates growth and is often present during sporadic breast cancer progression. *Nat Genet*, 9:444-50.
- Thorlacius S, Sigurdsson S, Bjarnadottir H, Olafsdottir G, Jonasson JG, Tryggvadottir L, Tulinius H and Eyfjord JE (1997): Study of a single BRCA2 mutation with high carrier frequency in a small population. *Am J Hum Genet*, 60:1079-84.
- Thorlacius S, Struewing JP, Hartge P, Olafsdottir GH, Sigvaldason H, Tryggvadottir L, Wacholder S, Tulinius H and Eyfjord JE (1998): Population-based study of risk of breast cancer in carriers of BRCA2 mutation. *Lancet*, 352:1337-9.
- Tibbetts RS, Cortez D, Brumbaugh KM, Scully R, Livingston D, Elledge SJ and Abraham RT (2000): Functional interactions between BRCA1 and the checkpoint kinase ATR during genotoxic stress. *Genes Dev*, 14:2989-3002.
- Tirkkonen M, Johannsson O, Agnarsson BA, Olsson H, Ingvarsson S, Karhu R, Tanner M, Isola J, Barkardottir RB, Borg A and Kallioniemi OP (1997a): Distinct somatic genetic changes associated with tumor progression in carriers of BRCA1 and BRCA2 germ-line mutations. *Cancer Res*, 57:1222-7.
- Tirkkonen M, Johannsson O, Agnarsson BA, Olsson H, Ingvarsson S, Karhu R, Tanner M, Isola J, Barkardottir RB, Borg Å and Kallioniemi OP (1997b): Distinct somatic genetic changes associated



## REFERENCES

- with tumor progression in carriers of BRCA1 and BRCA2 germ-line mutations. *Cancer Res*, 57:1222-7.
- Tomlinson GE, Chen TT, Stastny VA, Virmani AK, Spillman MA, Tonk V, Blum JL, Schneider NR, Wistuba II, Shay JW, Minna JD and Gazdar AF (1998): Characterization of a breast cancer cell line derived from a germ-line BRCA1 mutation carrier. *Cancer Res*, 58:3237-42.
- Tseng SL, Yu IC, Yue CT, Chang SF, Chang TM, Wu CW and Shen CY (1997): Allelic loss at BRCA1, BRCA2, and adjacent loci in relation to TP53 abnormality in breast cancer. *Genes Chromosomes Cancer*, 20:377-82.
- Tsou HC, Teng DH, Ping XL, Brancolini V, Davis T, Hu R, Xie XX, Gruener AC, Schrager CA, Christiano AM, Eng C, Steck P, Ott J, Tavtigian SV and Peacocke M (1997): The role of MMAC1 mutations in early-onset breast cancer: causative in association with Cowden syndrome and excluded in BRCA1-negative cases. *Am J Hum Genet*, 61:1036-43.
- Tutt A, Bertwistle D, Valentine J, Gabriel A, Swift S, Ross G, Griffin C, Thacker J and Ashworth A (2001): Mutation in Brca2 stimulates error-prone homology-directed repair of DNA double-strand breaks occurring between repeated sequences. *Embo J*, 20:4704-16.
- Wagner TM, Hirtenlehner K, Shen P, Moeslinger R, Muhr D, Fleischmann E, Concin H, Doeller W, Haid A, Lang AH, Mayer P, Petru E, Ropp E, Langbauer G, Kubista E, Scheiner O, Underhill P, Mountain J, Stierer M, Zielinski C and Oefner P (1999): Global sequence diversity of BRCA2: analysis of 71 breast cancer families and 95 control individuals of worldwide populations. *Hum Mol Genet*, 8:413-23.
- Vahteristo P, Bartkova J, Eerola H, Syrjälöski K, Ojala S, Kilpivaara O, Tamminen A, Kononen J, Aittomäki K, Heikkilä P, Holli K, Blomqvist C, Bartek J, Kallioniemi OP and Nevanlinna H (2002): A CHEK2 genetic variant contributing to a substantial fraction of familial breast cancer. *Am J Hum Genet*, 71:432-8.
- Vahteristo P, Eerola H, Tamminen A, Blomqvist C and Nevanlinna H (2001): A probability model for predicting BRCA1 and BRCA2 mutations in breast and breast-ovarian cancer families. *Br J Cancer*, 84:704-8.
- van den Berg J, Johannsson O, Hakansson S, Olsson H and Borg A (1996): Allelic loss at chromosome 13q12-q13 is associated with poor prognosis in familial and sporadic breast cancer. *Br J Cancer*, 74:1615-9.
- Wang A, Schneider-Broussard R, Kumar AP, MacLeod MC and Johnson DG (2000a): Regulation of BRCA1 expression by the Rb-E2F pathway. *J Biol Chem*, 275:4532-6.
- Wang Q, Zhang H, Kajino K and Greene MI (1998): BRCA1 binds c-Myc and inhibits its transcriptional and transforming activity in cells. *Oncogene*, 17:1939-48.
- Wang SC, Lin SH, Su LK and Hung MC (1997): Changes in BRCA2 expression during progression of the cell cycle. *Biochem Biophys Res Commun*, 234:247-51.
- Wang SC, Shao R, Pao AY, Zhang S, Hung MC and Su LK (2002): Inhibition of cancer cell growth by BRCA2. *Cancer Res*, 62:1311-4.
- Wang Y, Cortez D, Yazdi P, Neff N, Elledge SJ and Qin J (2000b): BASC, a super complex of BRCA1-associated proteins involved in the recognition and repair of aberrant DNA structures. *Genes Dev*, 14:927-39.
- Warner E, Foulkes W, Goodwin P, Meschino W, Blondal J, Paterson C, Ozcelik H, Goss P, Allingham-Hawkins D, Hamel N, Di Prospero L, Contiga V, Serruya C, Klein M, Moslehi R, Honeyford J, Liede A, Glendon G, Brunet JS and Narod S (1999): Prevalence and penetrance of BRCA1 and BRCA2 gene mutations in unselected Ashkenazi Jewish women with breast cancer. *J Natl Cancer Inst*, 91:1241-7.
- Weaver Z, Montagna C, Xu X, Howard T, Gadina M, Brodie SG, Deng CX and Ried T (2002): Mammary tumors in mice conditionally mutant for Brca1 exhibit gross genomic instability and centrosome amplification yet display a recurring distribution of genomic imbalances that is similar to human breast cancer. *Oncogene*, 21:5097-107.
- Vehmanen P, Friedman LS, Eerola H, McClure M, Ward B, Sarantaus L, Kainu T, Syrjälöski K, Pyrhönen S, Kallioniemi OP, Muhonen T, Luce M, Frank TS and Nevanlinna H (1997a): Low proportion of BRCA1 and BRCA2 mutations in Finnish breast cancer families: evidence for additional susceptibility genes. *Hum Mol Genet*, 6:2309-15.
- Vehmanen P, Friedman LS, Eerola H, Sarantaus L, Pyrhönen S, Ponder BA, Muhonen T and Nevanlinna H (1997b): A low proportion of BRCA2 mutations in Finnish breast cancer families. *Am J Hum Genet*, 60:1050-8.
- Welsh PL and King MC (2001): BRCA1 and BRCA2 and the genetics of breast and ovarian cancer. *Hum Mol Genet*, 10:705-13.

## REFERENCES

- Welsh PL, Owens KN and King MC (2000): Insights into the functions of BRCA1 and BRCA2. *Trends Genet*, 16:69-74.
- Venkitaraman AR (2002): Cancer susceptibility and the functions of BRCA1 and BRCA2. *Cell*, 108:171-82.
- Verhoog LC, Brekelmans CT, Seynaeve C, Dahmen G, van Geel AN, Bartels CC, Tilanus-Linthorst MM, Wagner A, Devilee P, Halley DJ, van den Ouweland AM, Meijers-Heijboer EJ and Klijn JG (1999): Survival in hereditary breast cancer associated with germline mutations of BRCA2. *J Clin Oncol*, 17:3396-402.
- Verhoog LC, Brekelmans CT, Seynaeve C, van den Bosch LM, Dahmen G, van Geel AN, Tilanus-Linthorst MM, Bartels CC, Wagner A, van den Ouweland A, Devilee P, Meijers-Heijboer EJ and Klijn JG (1998): Survival and tumour characteristics of breast-cancer patients with germline mutations of BRCA1. *Lancet*, 351:316-21.
- Wessels LF, van Welsem T, Hart AA, van't Veer LJ, Reinders MJ and Nederlof PM (2002): Molecular classification of breast carcinomas by comparative genomic hybridization: a specific somatic genetic profile for BRCA1 tumors. *Cancer Res*, 62:7110-7.
- Williams RS and Glover JN (2002): Structural consequences of a cancer-causing BRCA1-BRCT missense mutation. *J Biol Chem*.
- Wilson CA, Payton MN, Elliott GS, Buaas FW, Cajulis EE, Grosshans D, Ramos L, Reese DM, Slamon DJ and Calzone FJ (1997): Differential subcellular localization, expression and biological toxicity of BRCA1 and the splice variant BRCA1-delta1b. *Oncogene*, 14:1-16.
- Wilson CA, Payton MN, Pekar SK, Zhang K, Pacifici RE, Gudas JL, Thukral S, Calzone FJ, Reese DM and Slamon DJ (1996): BRCA1 protein products: antibody specificity. *Nat Genet*, 13:264-5.
- Wilson CA, Ramos L, Villasenor MR, Anders KH, Press MF, Clarke K, Karlan B, Chen JJ, Scully R, Livingston D, Zuch RH, Kanter MH, Cohen S, Calzone FJ and Slamon DJ (1999): Localization of human BRCA1 and its loss in high-grade, non-inherited breast carcinomas. *Nat Genet*, 21:236-40.
- Wittwer CT, Ririe KM, Andrew RV, David DA, Gundry RA and Balis UJ (1997): The LightCycler: a microvolume multisample fluorimeter with rapid temperature control. *Biotechniques*, 22:176-81.
- Wong AK, Pero R, Ormonde PA, Tavtigian SV and Bartel PL (1997): RAD51 interacts with the evolutionarily conserved BRC motifs in the human breast cancer susceptibility gene *brca2*. *J Biol Chem*, 272:31941-4.
- Wong JM, Ionescu D and Ingles CJ (2003): Interaction between BRCA2 and replication protein A is compromised by a cancer-predisposing mutation in BRCA2. *Oncogene*, 22:28-33.
- Wooster R, Bignell G, Lancaster J, Swift S, Seal S, Mangion J, Collins N, Gregory S, Gumbs C and Micklem G (1995): Identification of the breast cancer susceptibility gene BRCA2. *Nature*, 378:789-92.
- Wooster R, Neuhausen SL, Mangion J, Quirk Y, Ford D, Collins N, Nguyen K, Seal S, Tran T, Averill D, Fields P, Marshall G, Narod S, Lenoir GM, Lynch H, Feunteun J, Devilee P, Cornelisse CJ, Menko FH, Daly PA, Ormiston W, McManus R, Pye C, Lewis CM, Cannon-Albright LA, Peto J, Ponder BAJ, Skolnick MH, Easton DF, Goldgar DE and Stratton MR (1994): Localization of a breast cancer susceptibility gene, BRCA2, to chromosome 13q12-13. *Science*, 265:2088-90.
- Wu LC, Wang ZW, Tsan JT, Spillman MA, Phung A, Xu XL, Yang MC, Hwang LY, Bowcock AM and Baer R (1996): Identification of a RING protein that can interact in vivo with the BRCA1 gene product. *Nat Genet*, 14:430-40.
- Xia F, Taghian DG, DeFrank JS, Zeng ZC, Willers H, Iliakis G and Powell SN (2001): Deficiency of human BRCA2 leads to impaired homologous recombination but maintains normal nonhomologous end joining. *Proc Natl Acad Sci U S A*, 98:8644-9.
- Xu B, Kim S and Kastan MB (2001): Involvement of Brca1 in S-phase and G(2)-phase checkpoints after ionizing irradiation. *Mol Cell Biol*, 21:3445-50.
- Xu X, Wagner KU, Larson D, Weaver Z, Li C, Ried T, Hennighausen L, Wynshaw-Boris A and Deng CX (1999a): Conditional mutation of *Brca1* in mammary epithelial cells results in blunted ductal morphogenesis and tumour formation. *Nat Genet*, 22:37-43.
- Xu X, Weaver Z, Linke SP, Li C, Gotay J, Wang XW, Harris CC, Ried T and Deng CX (1999b): Centrosome amplification and a defective G2-M cell cycle checkpoint induce genetic instability in BRCA1 exon 11 isoform-deficient cells. *Mol Cell*, 3:389-95.
- Yan H, Dobbie Z, Gruber SB, Markowitz S, Romans K, Giardiello FM, Kinzler KW and Vogelstein B (2002): Small changes in expression affect reposition to tumorigenesis. *Nat Genet*, 30:25-6.
- Yang Q, Sakurai T, Mori I, Yoshimura G, Nakamura M, Nakamura Y, Suzuma T, Tamaki T, Umemura T and Kakudo K (2001): Prognostic significance of BRCA1 expression in Japanese sporadic breast carcinomas. *Cancer*, 92:54-60.
- Yang YH, Dudoit S, Luu P, Lin DM, Peng V, Ngai J and Speed TP (2002): Normalization for cDNA microarray data: a robust composite method addressing single and multiple slide systematic variation. *Nucleic Acids Res*, 30:e15.

## REFERENCES

- Yarden RI and Brody LC (1999): BRCA1 interacts with components of the histone deacetylase complex. *Proc Natl Acad Sci U S A*, 96:4983-8.
- Yeh S, Hu YC, Rahman M, Lin HK, Hsu CL, Ting HJ, Kang HY and Chang C (2000): Increase of androgen-induced cell death and androgen receptor transactivation by BRCA1 in prostate cancer cells. *Proc Natl Acad Sci U S A*, 97:11256-61.
- Yoshikawa K, Honda K, Inamoto T, Shinohara H, Yamauchi A, Suga K, Okuyama T, Shimada T, Kodama H, Noguchi S, Gazdar AF, Yamaoka Y and Takahashi R (1999): Reduction of BRCA1 protein expression in Japanese sporadic breast carcinomas and its frequent loss in BRCA1-associated cases. *Clin Cancer Res*, 5:1249-61.
- Yu VP, Koehler M, Steinlein C, Schmid M, Hanakahi LA, van Gool AJ, West SC and Venkitaraman AR (2000): Gross chromosomal rearrangements and genetic exchange between nonhomologous chromosomes following BRCA2 inactivation. *Genes Dev*, 14:1400-6.
- Zhang H, Somasundaram K, Peng Y, Tian H, Bi D, Weber BL and El-Deiry WS (1998a): BRCA1 physically associates with p53 and stimulates its transcriptional activity. *Oncogene*, 16:1713-21.
- Zhang H, Tomblin G and Weber BL (1998b): BRCA1, BRCA2, and DNA damage response: collision or collusion? *Cell*, 92:433-6.
- Zheng L, Annab LA, Afshari CA, Lee WH and Boyer TG (2001): BRCA1 mediates ligand-independent transcriptional repression of the estrogen receptor. *Proc Natl Acad Sci U S A*, 98:9587-92.
- Zheng L, Li S, Boyer TG and Lee WH (2000a): Lessons learned from BRCA1 and BRCA2. *Oncogene*, 19:6159-75.
- Zheng L, Pan H, Li S, Flesken-Nikitin A, Chen PL, Boyer TG and Lee WH (2000b): Sequence-specific transcriptional corepressor function for BRCA1 through a novel zinc finger protein, ZBRK1. *Mol Cell*, 6:757-68.
- Zhong Q, Chen CF, Li S, Chen Y, Wang CC, Xiao J, Chen PL, Sharp ZD and Lee WH (1999): Association of BRCA1 with the hRad50-hMre11-p95 complex and the DNA damage response. *Science*, 285:747-50.

## **Original communications**