

Gerhard A. Baer (ed.)

Joint Papers on Jet Ventilation

Paper Collection initiated by the
European Society for Jet Ventilation,
June, 2010

Joint Papers on Jet Ventilation 2011

Contents

	Preface		3
1	Technology of Jet Ventilation	Virtanen, Jani K., Karvinen, Reijo	5
2	Jet Ventilation Settings and setting Changes	Biro, Peter	18
3	Driving gas conditioning in Jet Ventilation	Biro, Peter	23
4	Monitoring during Jet Ventilation	Paloheimo, Markku	26
5	Safe Jet Ventilation	Baer, Gerhard A.	31
6	Endolaryngeal Procedures: Conventional Intubation vs. Infra- and Supra-glottic JV	Baer, Gerhard A.	37
7	20 Years of Experience with Normofrequent subglottic/intratracheal Jet Ventilation	Samarütel, Jüri	43
8	Jet Ventilation and LASER for Endolaryngeal Procedures	Pukander, Juhani	45
9	Jet Ventilation for Difficult Intubation and Emergencies	Janjevic, Dusanka	49
10	JV in the Presence of Airway Stenosis: advantages, drawbacks, and complications	Ihra, Gerald	55

Preface

Jet ventilation in the airway during general anaesthesia provides the endoscopist with an unobstructed view on a quiet operation field but preserves the anaesthesiologist's ability to control the patient's ventilation and oxygenation. It is now more than 40 years with jet ventilation for rigid bronchoscopy (Sanders 1967)¹ and almost exactly 40 years since introduction of intratracheal (percutaneous, Spoerel 1971)², supra-glottic (Barr1971)³, and intracheal translaryngeal (Spoerel1973)⁴ jet ventilation for endolaryngeal procedures. The risks of the new ventilation methods and how to avoid complications had been discussed within the following decade¹⁻⁷. Laser surgery in the airway⁸ brought new problems, which had been principally solved within another decade⁹.

However, avoidable complications still appear and discredit jet ventilation, which is also a last option to save a patient's life in airway emergencies. Emerging are also new uses of jet ventilation in lung surgery and interventional radiology. The European Society for Jet Ventilation (www.ESJV.org) was founded to keep alive and public the available experience.

The aim of a meeting on jet ventilation to be held in Tampere, June 2010, was that of the Society:

- to improve understanding of basic aspects of jet technology
- to distribute knowledge of different techniques and when to use them
- to help with selection of appropriate equipment
- to exchange experience and to discuss results
- to increase awareness of possible complications and
- how to avoid complications in all medical specialties possibly involved in jet ventilation.

Speakers had been invited to present established methods, their experience with special applications, and to discuss problems with jet ventilation. Unfortunately the meeting had to be cancelled because of too low a number of participants.

The Society still sees the need for publishing the meeting's content. Fortunately the majority of the invited speakers agreed and found the time to write, which is gratefully noted. The papers do not cover the whole field of jet ventilation but present basic knowledge and the most frequently used applications. Unfortunately the

publication lacks the planned discussions on technology and safety. Despite the limitations the authors hope the publications may help when planning research or when preparing to use jet ventilation in clinical work.

Tampere, May 2012 Gerhard Baer

Reference List

1. Sanders RD: Two ventilating attachments for bronchoscopes. Delaware M J 1967; 39: 170-5, 192
2. Spoerel WE, Narayanan PS, Singh NP: Transtracheal ventilation. Br J Anaesth 1971; 43: 932-9
3. Barr NL, Itscoitz S, Chan.C., Economopoulos B, Albert SN: Oxygen injection in suspension laryngoscopy. Arch Otolaryngol 1971; 93: 606-9
4. Spoerel WE, Greenway RE: Technique of ventilation during endolaryngeal surgery under general anaesthesia. Can Anaesth Soc J 1973; 20: 369-77
5. Carden E, Crutchfield W: Anaesthesia for microsurgery of the larynx (A new method). Can Anaesth Soc J 1973; 20: 378-89
6. Smith RB, Schaer WB, Pfaeffle H: Percutaneous transtrachel ventilation for anaesthesia and resuscitation: a review and report of complications. Can Anaesth Soc J 1975; 22: 607-12
7. Klain M, Smith RB: Fluidic technology. A discussion and a description of a fluidic controlled ventilator for use with high flow oxygen techniques. Anaesthesia 1976; 31: 750-7
8. Strong MS, Jako GJ, Polanyi T, Wallace RA: Laser surgery in the aerodigestive tract. Am J Surg 1973; 126: 529-33
9. Ossoff RH: Laser safety in otolaryngology - head and neck surgery: anesthetic and educational considerations for laryngeal surgery. Laryngoscope 1989; 99: 1-26

Technology of Jet Ventilation

J.K. Virtanen* and R. Karvinen*

* Department of Energy and Process Engineering,
Tampere University of Technology, Tampere, FI 33101, Finland
jani.virtanen@tut.fi and reijo.karvinen@tut.fi

There is no person to admire for creation of the jet pump. The first mentioning of the principle is around 1800 in England. Jet pumps have been developed for different purposes via trial and error until recently. Nowadays almost all details of its function are known and calculable.

Operation principle of jet pumps

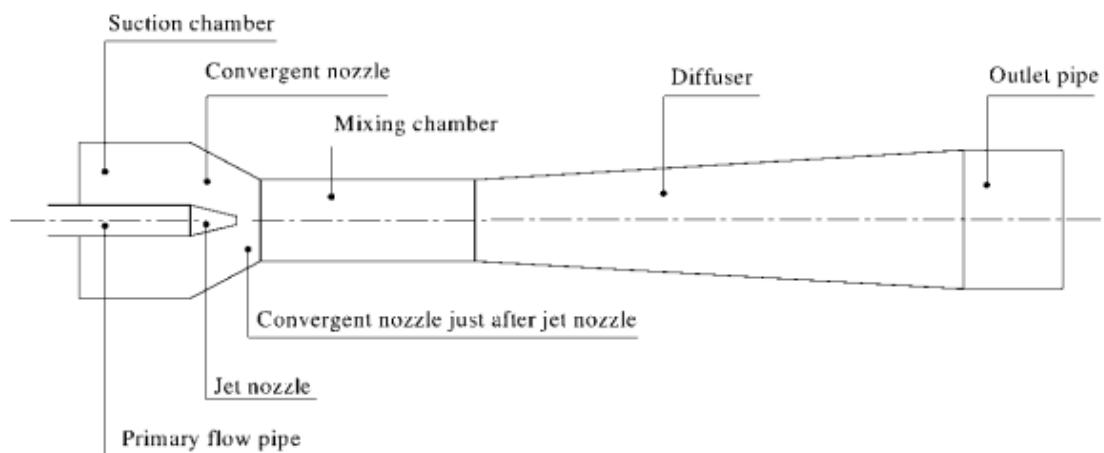

Figure 1. Different parts of jet pump¹⁰

Fluid jet from a power fluid nozzle creates a lower pressure in the throat inlet than that in the suction chamber, which causes the pumping effect, see Figure 2.

- Benefits: simple, reliable operation.
- Drawbacks: low efficiency.

Pressure distribution in a jet pump

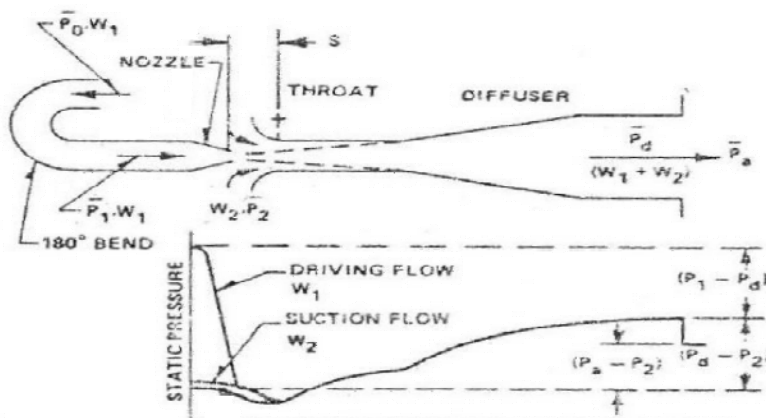

Figure 2. Power and suction fluid pressures in principle.¹¹

First the pressure drops at the throat inlet, which causes the suction phenomena. The pressure rises in the throat as the mixing of power and suction fluids proceeds. Typical required throat lengths are 4 to 8 throat diameters ¹². In the diffuser kinetic energy $p_{dyn} = \frac{1}{2} \rho U^2$ changes into static pressure p_{stat} .

Jet pump applications

- Water raising (water-water): Thomson (1852) ¹³
- Vacuum creation (air-air)
- Power stations ¹¹
- Steam jet pump for removing water (gas-liquid) ¹⁴
- mixing and dosing purposes [6] ¹⁵
- Pumping liquids containing solids (liquid – gas-solid) ¹⁵
- Oil pumping (liquid – liquid-gas-solid) ¹⁶
- Continuous casting of steel
- Aeration of pollutet waters
- Flotation deinking aeration ¹⁷
- Automotive fuel injection
- Jet pump ventilation

Jet pumps

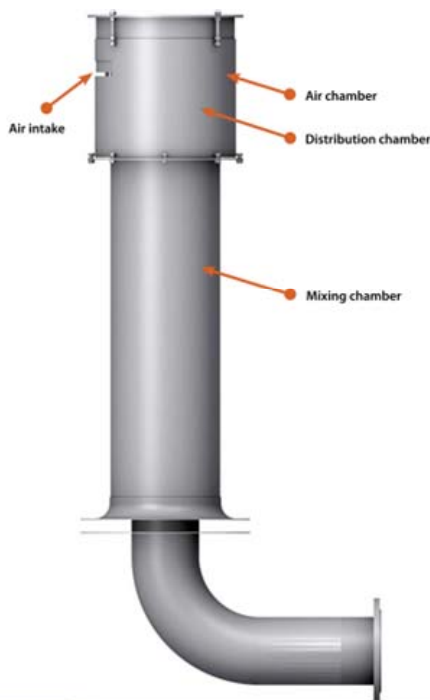

Figure 3a. Metso™ OptiCell flotation deinking injector.

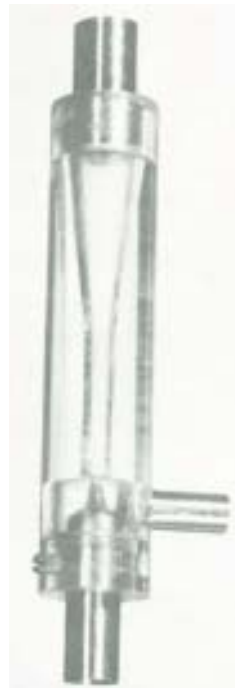

Figure 3b. Jet pump for metered dosing of chemicals [6].

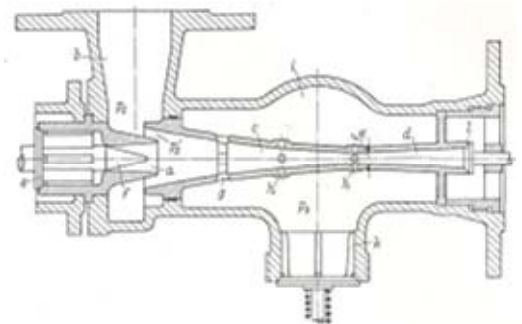

Figure 3c. Steam jet pump for pumping water [5].



Figure 3d. TTYLiquid jet gas pump [9].

For technicians, calculating jet pump performance is quite simple, because the pump's structures are optimally formed and do not change during operation. Some Examples:

Equations for incompressible fluids:

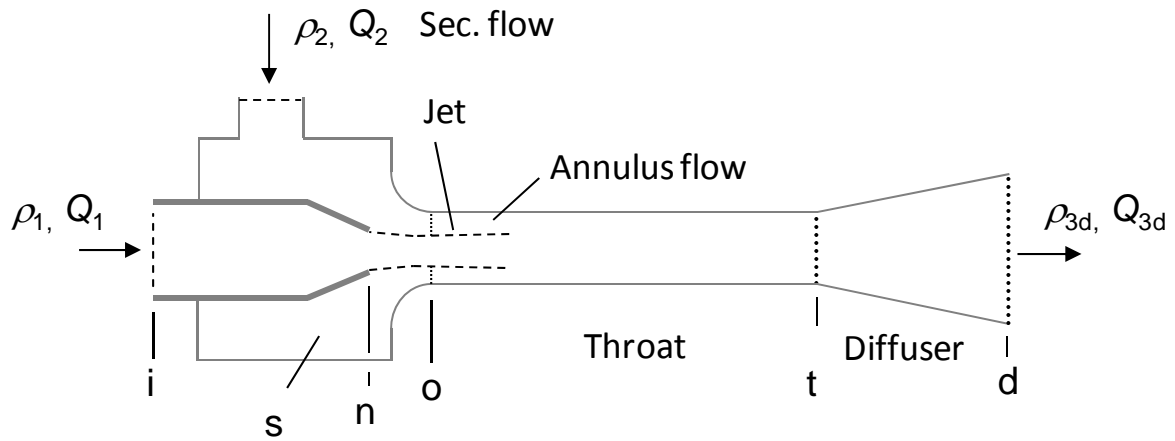

Figure 4. LJJ-pump and nomenclature

Nozzle Eq.: $p_1 - p_o = Z(1 + K_n) \quad , Z = \frac{1}{2}\rho_1 U_n^2$

Sec. flow Eq.: $p_s - p_o = Z \frac{SM^2}{c^2} (1 + K_{en})$

Throat Eq.: $p_t - p_o = Z \left[2b + 2SM^2 \frac{b^2}{1-b} - b^2(2 + K_t)(1 + SM)(1 + M) \right]$

Diffuser Eq.: $p_d - p_t = Zb^2 \left[\frac{1 + SM}{1 + M} \right] (1 + M)^2 [1 - a^2 - K_d]$

Equations become even simpler if the pumped fluid is the same as the power fluid: $S = \rho_2/\rho_1=1$

Diffuser to throat area ratio squared is often negligible: $a^2 = (A_t/A_d)^2 \approx 0$

The forms above are simple when compared to those valid for compressible gas/gas jet pumps.

Jet pumps are characterized by energy losses through friction, which needs to be known.

Friction losses

- Jet pump equations contain friction coefficients for nozzle K_n , secondary flow entrance K_e , throat K_t and diffuser K_d . The pressure losses are based on form $\Delta p_f = K\rho U^2/2$.
 - Density and velocity are defined in locations (see Figure 4) n for nozzle, o -annulus for entrance and t for both throat and diffuser¹⁸.
- Friction coefficients are determined by the pump geometry and fluid properties. They can be measured or found from literature¹⁶.
- For LJJ-pump (incompressible) the friction coefficients remain constants i.e. pressures or flow ratios have no influence¹².

- For liquid-jet gas pump (LJG-pump) the friction coefficients remain constants only for a constant nondimensional jet pump number $n=2Zb^2c/p_o$ ¹².

Efficiency

Jet pump efficiency is defined as the ratio of work done to the fluid that is pumped versus the energy used for pumping:

$$\eta = \frac{p_s Q_s \ln(p_d/p_s) + Q_2 (p_d - p_s)}{Q_1 (p_1 - p_d)} = N_G \phi_s + NM$$

$$N_G = \frac{p_s \ln(p_d/p_s)}{p_1 - p_d}, \quad \phi_s = \frac{Q_2 Q_o}{Q_1} \quad N = \frac{(p_d - p_s)}{(p_1 - p_d)}, \quad M = \frac{Q_2}{Q_1}$$

- For incompressible flow the efficiency is only the product of dimensionless head ratio N and suction ratio M .
- Further, the N - M -curve is constant for a L JL-pump with fixed geometry and fluids (friction coefficients are also constant) ¹⁹.
- Maximum efficiencies are about 43 % for L JL and L JG -pumps and about 50 % for L JGL-pumps ²⁰.

Performance – Nozzles

- The nozzle is a very important part of a jet pump. Here is shown a great effect to the air suction performance of liquid jet gas (LJG) –pump measured at TTY ²¹.

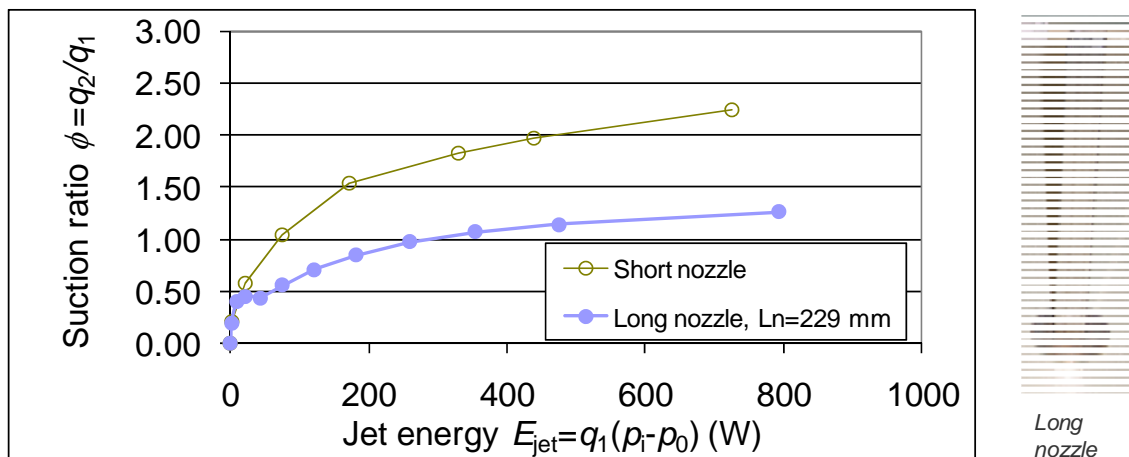

Figure 5. Air suction performance for short and long square-edge profiled nozzles with $b=0.287$. ($H_d=700 \text{ mmH}_2\text{O}$, $p_s \approx p_o$, $L_t = 1.008\text{m}$) ²¹.

Performance – Area ratio $b = A_n/A$

- Area ratio b is another jet pump key parameter. High b -values create high pumping pressure and low suction whereas a low b -value pump has high suction ratio but low output pressure.

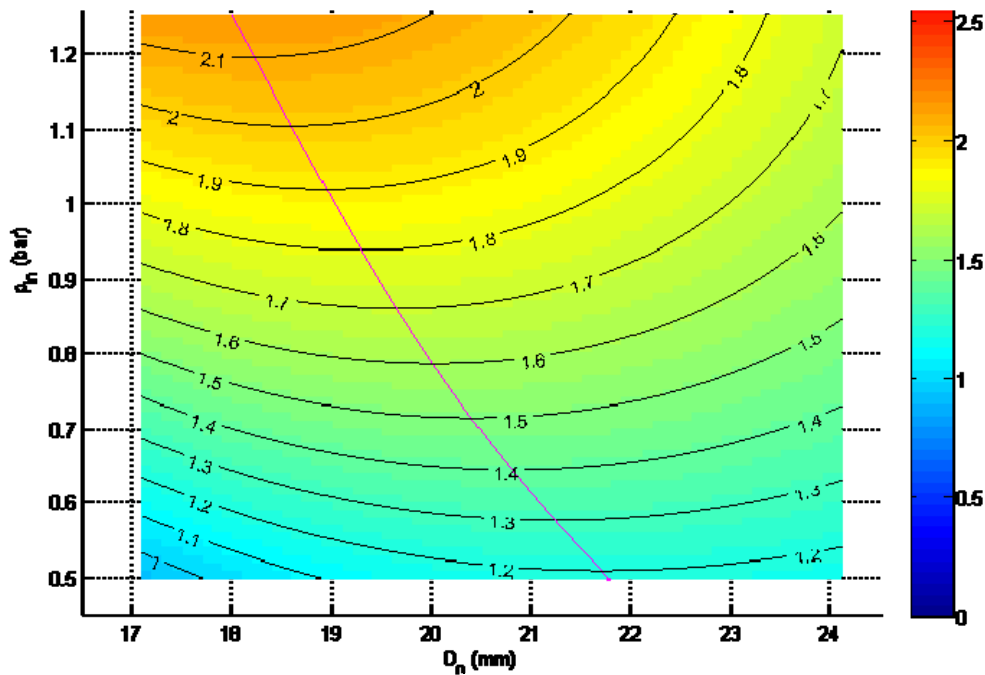

Figure 6. Measured air suction performance ϕ_s as a function of jet pressure p_i and nozzle diameter D_n ($b=D_n^2/42^2$) for short nozzle having triangular cross section ($H_d=700\text{ mmH}_2\text{O}$, $p_s \approx p_0$, $L_t=1.008\text{m}$, interpolated from 16 measurement points) ²¹.

Jet Ventilation – Measurements

- For defining the jet pump operation the minimum requirements are measurements for three pressures p_i , p_s , p_d and two flow rates Q_1 , Q_2 .
- **Friction factors (K_n , K_s , K_t , K_d) and the NM-curve can be defined** as a series of these measurements.
 - Typically the pressure measurements are tried to take as close to the jet pump as possible in order to reduce the effect of piping friction losses etc. ¹⁹.

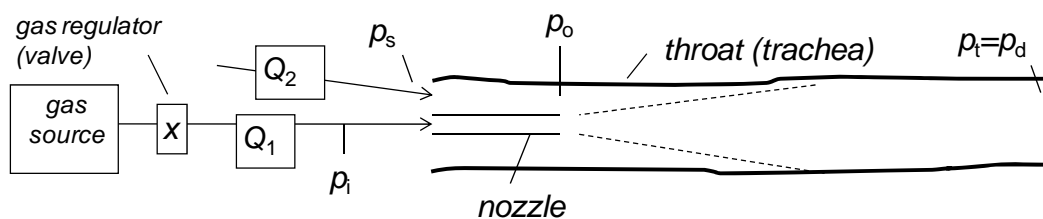

Figure 7. Required jet pump measurements.

The Example of Intratracheal Jet Ventilation for Laryngomicroscopy

- Human trachea sizes have been measured and reported by Baer et al 1987 ²², see Table 1. An average size at ring 12 is chosen for the example case => $A_t=233.5\text{ mm}^2$. It is important to notice that the range of human trachea areas is very wide, $A_t=96\dots462\text{ mm}^2$.

Table 1. Human trachea sizes²²

Convergent tracheas, n=111				Divergent tracheas, n=78			
Ring	mean	SD	Range	Ring	mean	SD	Range
7	268	62	114-462 mm ²	7	206	49.5	114-308 mm ²
12	232	55.6	96-364 mm ²	12	235	56.2	138-396 mm ²

- Shape of the example case trachea is chosen to be somewhat asymmetric according to measures given by Baer et al.²², see Figure 8.
- Nozzle (catheter) sizes from²², $D_n=2.2$ mm, $O_d=3.4$ mm
- Longitudinal divergence or convergence is quite small and therefore neglected²². Length measures has been guessed, nozzle: $L_n=240$ mm, suction chamber (upper trachea and laryngoscope) $L_s=200$ mm and throat (lower trachea) $L_t=200$ mm.

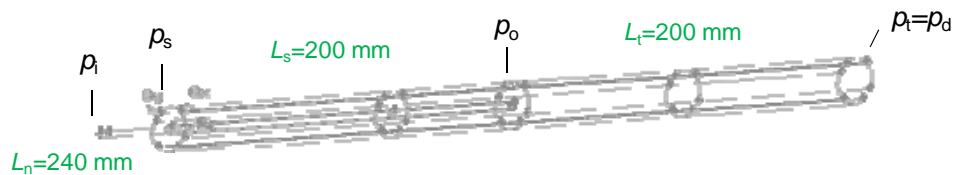

Figure 8. Throat (trachea) and nozzle geometry of example case.

CFD-solution for the example case

- The example case has been solved by using computational fluid dynamics (CFD) program (Fluent R13). Main features are:
 - Compressible (isentropic) air-air case (at operating pressure of 101325 Pa)
 - K-omega turbulence model
 - Back pressure $p_d=1471$ Pa (15 cmH2O at carina) taken from Albert et al 1972²³.
 - Suction pressure $p_s=0$ Pa, $T=293$ K (room pressure and temperature)
 - Nozzle pressure ($T=293$ K)
 - Multiple cases with different pressures $p_i=[140, 160, 180, 200]$ kPa

Overall CFD Results

Table 2. Main CFD inputs and results

Case	p_i (Pa)	p_s (Pa)	p_d (Pa)	N	q_1 (l/s)	q_2 (l/s)	M ()	eetta (%)	U_{jet} (m/s)	Z (pa)	T_{1n} (K)	ρ_{1n} (kg/m3)
6	120000	0	1471	0.012	0.879	neg.	#VALUE!	#VALUE!	231.3	35667	265	1.33
7	140000	0	1471	0.011	0.954	0.624	0.65	0.7 %	251	42951	260	1.36
5	160000	0	1471	0.009	1.025	2.233	2.18	2.0 %	270	50516	255	1.39
8	180000	0	1471	0.008	1.092	3.578	3.28	2.7 %	287	58475	250	1.42
2	200000	0	1471	0.007	1.155	4.616	4.00	3.0 %	304	66794	245	1.45

- The operation of the jet pump begins quite late, at about $U_{jet}=250$ m/s (140 kPa, see Table 2)

- The highest possible jet velocity for this nozzle type (straight pipe) is the velocity of sound in air, $c=313\text{m/s}$ at $T=243\text{K}$ ($c=343\text{m/s}$ at $T=293\text{K}$; for oxygen $c=327\text{m/s}$).
- Minimum required inlet pressure for this long nozzle (240mm) is about $p_i=140\text{kPa}$ (20.3psi). This is quite in accordance with the minimum value of 103kPa (15psi) reported by Fassl et al.²⁴ for a shorter catheter (Jelco IV 4068: 14-gauge, 2-1/4').
- Efficiency is very low, mainly because of small b-value ($b=0.016$) and high nozzle pressure loss (small diameter and great length).
- High nozzle pressure loss causes **nozzle dependent** compressibility effects:
- Jet temperature decreases (from 20°C to -13 to -30°C)
 - Jet density ρ_{1n} increases ($S=\rho_2/\rho_1 < 1$, $\rho_2=1.205\text{kg/m}^3$ at $T=293\text{K}$ and $p=101325\text{Pa}$).

NM- eta (η) Results

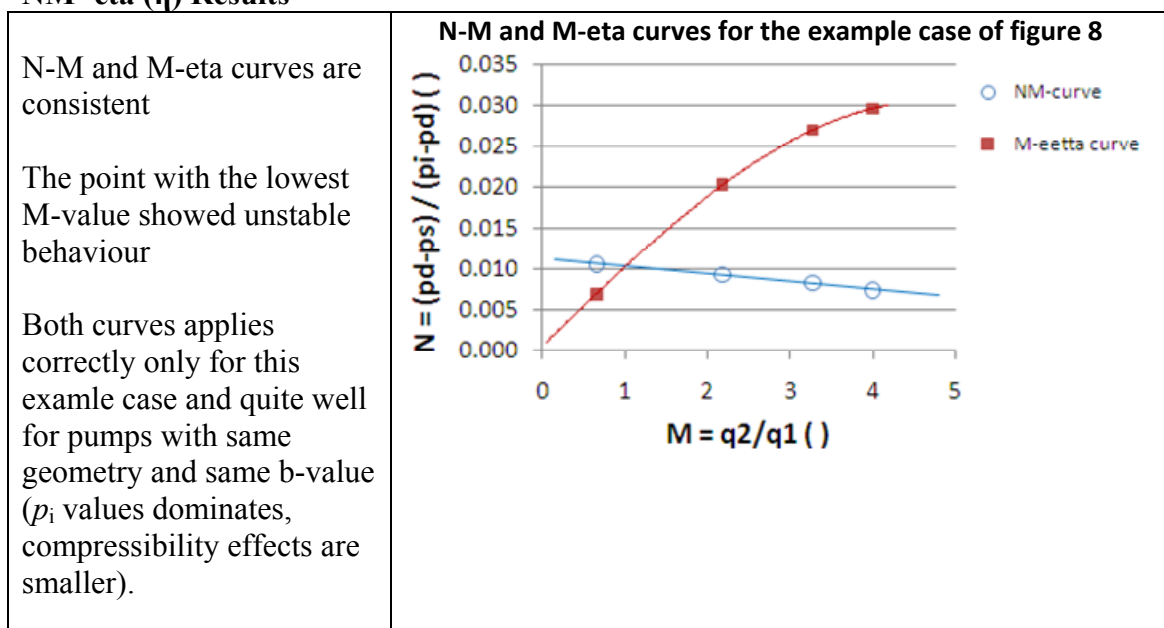

Figure 9. N-M and M-eta curves for example case.

1 D Theory

- Friction factors (K_n, K_s, K_t) and other relevant parameters for the incompressible 1D-theory (fig. 6) has been calculated from the CFD-results (Appendix 1).
- The measured friction factor values include some variation and the $M=0.65$ point varies much more (unstable).
- K_n, K_s, K_t and S has been taken from the last point ($M=4$). Theory fits well to the CFD-points despite that the real nozzle is compressible.

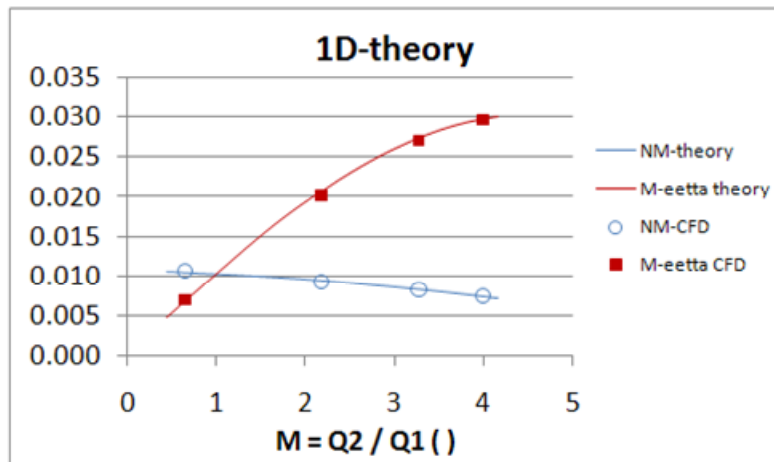

Figure 10. 1D-theory curves with $K_n=2$, $K_s=0.662$, $K_t=0.031$ and $S=0.833$ ($b=0.01628$).

Jet Ventilation – Simulation

- The known NM-curve or known constants for the 1D-theory can be used for **simulating jet ventilation cases** by changing some of the variables (constant b -value pump). For example:
 - Simulating the effect of inlet pressure p_i to the resulting (breathing) flow rate Q_3 .
 - Calculating required inlet pressures p_i for different back pressures p_d (lungs) with some wanted output flow rates Q_3 .
- The use of NM-curve is very simple. There is no need to know any other pump parameters **as long as the jet pump geometry stays the same.**
- 1D-theory is capable for more advanced simulations. For example different b -value pumps (throat or nozzle area changes) can be handled by forming models for the changing K -values.

Reference List

1. ElGazzar M, Meakhail M, Mikhail S: Numerical and experimental study of the influence of drag reduction agent (carboxy methyl cellulose) on the central jet pump. Proceedings of the Institution of Mechanical Engineers, Part A: Journal of Power and Energy 2007; 221: 1067-73
2. Kudirka, DeCoster: Jet pump cavitation with ambient and high temperature water. Journal of fluids engineering 1979; 101: 93-9
3. Cunningham RG, Dopkin RJ: Jet breakup and mixing throat lengths for the liquid jet gas pump. Journal of fluids engineering 1974; 96: 216-26
4. Thomson, J. On a jet pump or apparatus for drawing up water by the power of a jet. British Assn. Report 130, London 1852
5. Schulz H: Die Pumpen. Springer Verlag, 1977,
6. Wakefield, A. W. and Ruckley, A. L. Performance of solids handling jet pumps at low Reynolds's numbers. 1975. Cambridge. 2nd Symposium on jet pumps & gas lift techniques. Ref Type: Conference Proceeding
7. Mikhail S, et al.: Two-phase flow in jet pumps for different liquids. Journal of fluids engineering 2005; 127: 1038-42
8. Virtanen, J. K. and Honkanen, M. Effects of injector details on the bubble size distribution and flotation deinking. 2009. Kuopio. Papermaking Research Symposium. Ref Type: Conference Proceeding
9. Cunningham RG: Gas compression with the liquid jet pump. Journal of fluids engineering 1974; Sr.1: 203-15
10. Folsom, R. G. Predicting liquid jet pump performance. 1948. Proceedings of the National Conference on industrial hydraulics. Ref Type: Conference Proceeding
11. Cunningham RG: Liquid jet pumps for two phase flows. Journal of fluids engineering 1995; 117: 309-16
12. Virtanen, J. K. Injector design - A key to improved flotation deinking performance. Ref Type: Thesis/Dissertation (in progress)
13. Baer GA, Terho M, Tiensuu T: Morphologic study of the adult trachea at the 7th and 12th ring. A study on specimens from 205 autopsies. Surgical & Radiologic Anatomy 1987; 9: 169-72
14. Albert SN, Shibuya J, Albert CA: Ventilation with an oxygen injector for suspension laryngoscopy under general anaesthesia. Anesth Analg 1972; 51: 866-70
15. Fassel J, Jenny U, Nikiforov S, Murray WB, Foster PA: Pressures available for transtracheal jet ventilation from anesthesia machines and wall-mounted oxygen flowmeters. Anesth Analg 2010; 110: 94-100

Nomenclature

A = area (m²)

a = diffuser area ratio A_t/A_d

b = jet pump area ratio A_n/A_t

C = $A_2C_o/A_n = (A_t - A_n)/A_n = 1 - b/b$

D = diameter (m)

H = pressure head (mH₂O)

K = friction loss coefficient

L = length (m)

M = liquid-liquid suction ratio, Q_2/Q_2

N = head ratio $(p_d - p_x)/(p_i - p_d)$

NC = gas head ratio ,

$$p_2 \ln(p_d/p_2)/(p_i - p_d)$$

n = dimensionless jet pump number,

$$2Zb^2c/p_c$$

p = pressure (abs.) (Pa)

Q = volume flow rate (m³/s)

S = density ratio p_2/p_1

U = velocity (m/s)

Z = jet dynamic pressure (Pa)

μ = efficiency

Υ = gas density ratio at 3 p_{c2}/p_2

ρ = density (kg/m³)

ϕ = gas flow ratio at s Q_{c_x}/Q_2

Subscripts

1 = primary flow (liquid)

2 = liquid secondary flow

G = gas secondary flow

2G = bubbly secondary flow

2Go = bubbly secondary flow at o

3 = mixture of fluids 1, 2 and G

en = throat entry

i = location, Figure

n = nozzle

o = throat entry

s = suction chamber

t = throat end

d = diffuser end

Abbreviations

LJL = liquid jet – liquid –pump

LJG = liquid jet – gas-pump

LJLG = liquid jet – liquid-gas -pump

Appendix 1 – 1D-theory calculations

p0	T0 (K)	Rair (J/kgK)	ρ_2 (kg/m³)	Dn (mm)	An (mm²)	At (mm²)	b ()	kappa
101325	293	286.9	1.205	2.2	3.80	233.5	0.016	1.4

case nro	7	5	8	2
pi (Pa)	140000	160000	180000	200000
po (Pa)	-52	-107	-252	-404
Cd ()	1	1	1	1
An (mm ²)	3.80	3.80	3.80	3.80
q1 (l/s)	0.95	1.02	1.09	1.155
Un (m/s)	251	270	287	303.8
c (m/s)	323	320	317	314
Mach nro ()	0.78	0.84	0.91	0.97
Roo1_awa	1.363	1.391	1.418	1.447
Z (Pa)	42951	50516	58475	66794
Kn ()	2.26	2.17	2.08	2.00
T_stat_awa	259.9	255.0	250.1	245.4
At (mm ²)	233.5	233.5	233.5	233.5
b ()	0.0163	0.0163	0.0163	0.0163
c ()	60.4	60.4	60.4	60.4
Roo2 (kg/m3)	1.205	1.205	1.205	1.205
S ()	0.885	0.867	0.850	0.833
q2 (l/s)	0.62	2.23	3.58	4.616
M ()	0.65	2.18	3.28	4.00
ps (Pa)	0	0	0	0
Ks ()	10.62	0.87	0.72	0.66
h_out (cmH2O)	15	15	15	15
pt=p_out (Pa)	1471	1471	1471	1471
Kt ()	-5.89	-0.55	-0.13	0.03

Appendix 2 – CFD pressure profiles ($p_i=200$ kPa)

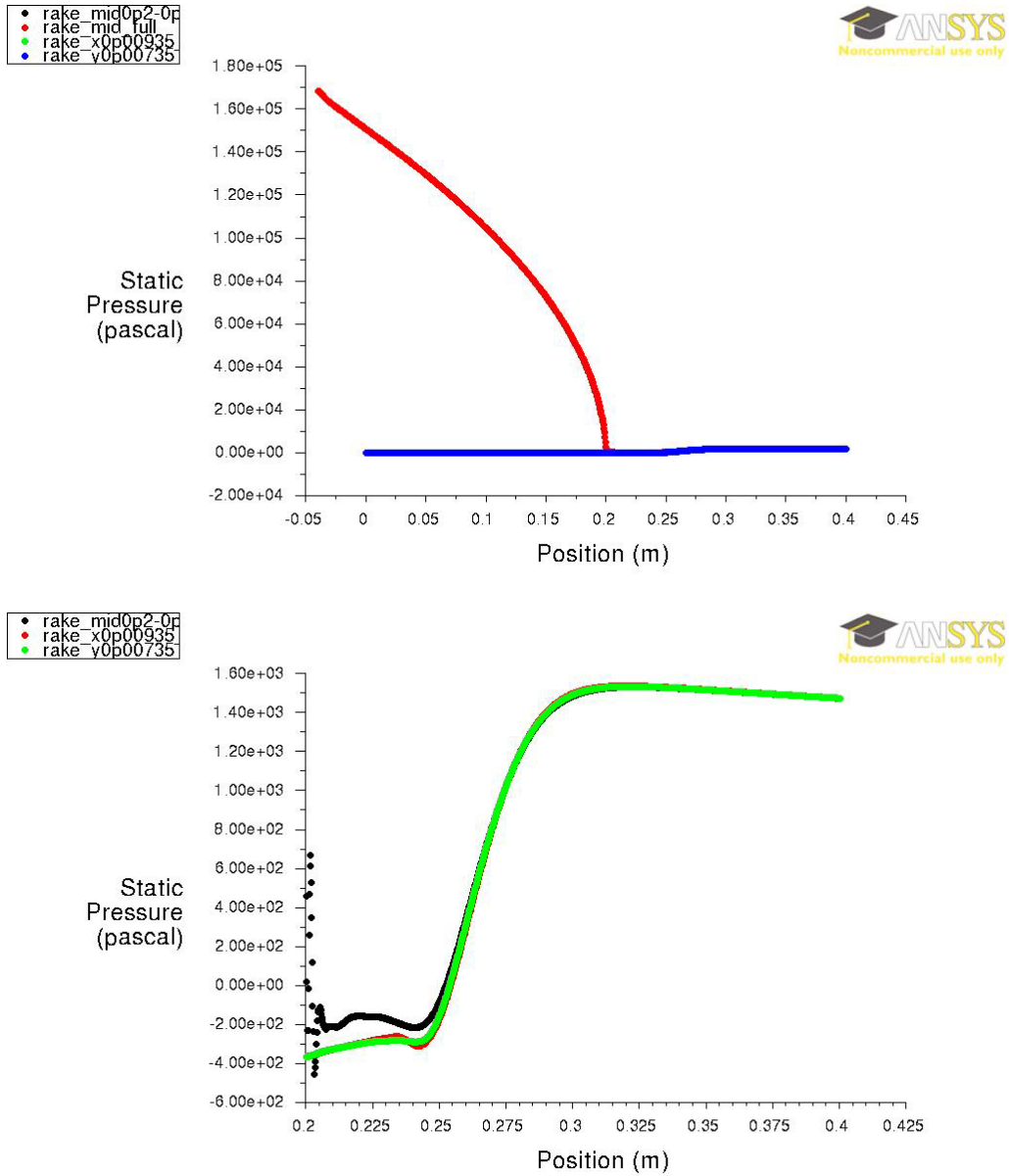

Figure A1. $p_i=200$ kPa example case pressure profiles at the middle of the geometry and at both trachea walls (x and y). Up: From nozzle inlet to throat outlet ($z=-0.04$ to 0.4 m), Down: From nozzle tip to throat outlet ($z=0.2$ to 0.4 m).

Appendix 3 – CFD contours for density and temperature ($p_i=140$ kPa)

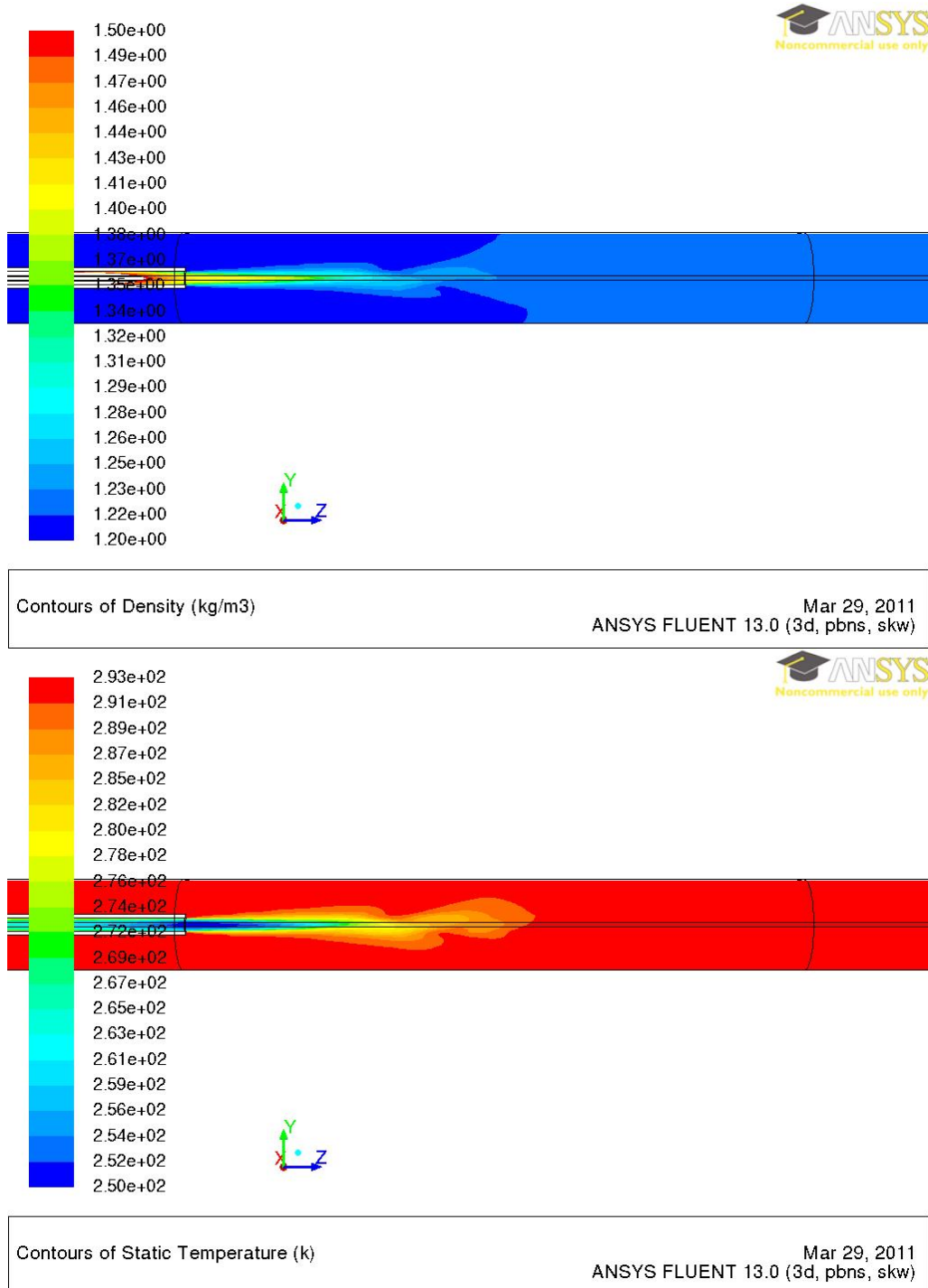

Figure A2. $p_i=140$ kPa example case density and temperature contours at the middle of the geometry ($x=0$ plane).

Jet ventilation settings and setting changes

P. Biro, University Hospital Zurich, Switzerland

Peter.Biro@usz.ch

Operating a jet ventilator needs certain knowledge about the settings and parameters that have to be controlled and measured during the application of this ventilation method on patients. The actual knowledge about this topic is mostly deriving from the experience of users and to a lower extent by evidence based investigations. However, there is some material about the interaction of certain ventilation settings and the resulting gas exchange parameters. One has to be aware of the limitations of these reports: no parameter remains stable even during unchanged settings, and modifications of settings are neither immediately, nor consistently and even less proportionally followed by changes in gas exchange parameters. Besides, during one intervention, the same settings may result over time in different parameters. The probably most important consequence of these statements is that jet ventilation needs continuous surveillance and immediate adjustments and readjustments of settings according to the prevailing situation. Therefore, handling of jet ventilation requires a pragmatic approach on an individual basis and remains to a large extent dependent on the personal experience of the user.

A fundamental issue in this context is the differentiation of settings that are given and remain unchanged (fix settings) such as Working Pressure, Cycles per Minute, Inspiration Duration, and Oxygen Concentration in the jet gas, while there are resulting settings such as Oxygen Concentration in the airway, Gas Volumes and Airway Pressure which are interdependent and may change by time.

Working Pressure

Working pressure (WP) is the gas pressure deriving from the external gas source that is translated through the jet tubing before the nozzle or the airway catheter. Modern jet ventilators do not generate the working pressure themselves, they only interrupt transmit the pressure from the gas source to the tubing, according to certain limitations set by the user. For that reason, the highest possible WP is near to the source pressure, but never exceeds it. WP has the strongest influence on the efficiency of gas exchange and in particular on CO₂ elimination¹. As typical for jet ventilation, there is no linear correlation between the WP and gas exchange parameters. Changes of WP produce non-proportional changes in the applied gas volumes.²

Cycles per Minute

Cycles per Minute (CpM) is a synonym for ventilation frequency, which in turn is the number of respiratory cycles generated per time. Usually the CpM are set at about

100 to 150 CpM, but in certain conditions this might vary between 12 (low frequency jet ventilation) to 300. In general one can say that higher frequencies allow a smoother working field for the surgeon, which is the main reason for the preference for high frequency application of jet ventilation. With this the amplitude of tidal movements within the operating field are smaller. However, with higher CpM the proportion of dead space increases too and this might reduce the efficiency of CO₂ elimination³ Before emergence of anaesthesia, and after the neuromuscular blockade has been completely reversed, the ventilation can be continued with an ever higher frequency, e.g. 300 CpM. With this setting, CO₂ is gradually accumulated, thus increasing the likelihood of spontaneous breathing. The latter does not interfere with the ventilation. When sufficient spontaneous tidal movements are present, the ventilation can be stopped and the jet catheter can be removed.

Oxygenation remains unaffected by the CpM over a large spectrum of settings. But with higher frequencies, there might build up some auto-PEEP, which is caused by shortening of the exhalation time duration. Due to the resistance of the exhalation pathway, the gas egress may be hindered and the auto-peep might reach to undesired values.⁴ This may have a minor beneficial impact on oxygenation.

Inspiration Duration

The duration of inspiration (ID) is an analogy for the same parameter during conventional ventilation: in jet ventilation it defines the ratio between the active insufflation time and the passive exhalation period. During the latter insufflation is simply halted. Accordingly, the ID value is presented as percentage of the insufflation time in relation to a complete respiratory cycle. The default value is usually set at 50%. Changes of ID have an immediate effect on the delivered gas volumes. Longer ID result in a shorter exhalation, and may increase the auto-PEEP⁵ These effects in turn are dependent on the CpM, so no blanket statements can be made for changes of ID. There is a trend for slight improvement of oxygenation by extending the ID, but this happens on the expense of carbon dioxide elimination. Secondly, there will be a shift of the thoracic excursions into a deeper inspiratory position, which in turn can lead to higher airway pressures and consecutively worsen gas exchange as well. In general one can state that modifications of the ID are usually followed by changes in other parameters, and that the resulting effects on gas exchange are unpredictable. Therefore it does not make much sense to vary the ID; it seems to be the best to keep it unchanged near by 50%.⁶

Oxygen Concentrations

The oxygen concentration (fraction) in the jet gas (F_{jetO₂}) results from the set mix of oxygen and air which is supplied from the high-pressure gas sources. This value can be varied between 0.21 (air) and 1.0 (pure oxygen). It is a common habit among users to equate the F_{jetO₂} with the inspiratory oxygen concentration as used in

conventional ventilation (F_{iO_2}). However, this analogy is not adequate because due to "air entrainment", the incoming oxygen concentration in the airway inevitably falls somewhat below the set F_{jetO_2} value. But the reduction in oxygen concentration is very unpredictable. The higher the F_{jetO_2} is set, the more pronounced this effect results. Besides, the negative effect of entrainment on oxygenation is highly dependent on the configuration of the ventilation equipment. The deeper the jet catheter is inserted into the respiratory tract, the less ambient air is entrained and the oxygen concentration remains less affected. The negative influence of entrainment is therefore the unpredictable lowering of the resulting oxygen concentration in the airway and lungs. While an increase in the F_{jetO_2} is the most likely measure to improve oxygenation, its reduction is a desirable objective in the application of laser beams. Even by avoiding the use of inflammable material, and exclusively using laser-resistant equipment, a certain risk of ignition and fire complications remains⁷. This is due to particles released from the tissue of the operated patient, which can ignite in an oxygen-rich atmosphere. To keep this risk to a minimum, the lowest possible oxygen concentration in the ventilation gas (<40%) has to be observed during activation of the laser device⁸

Gas Volumes

An important resulting parameter in JV is the delivered gas volume, expressed either as tidal volume ($TV = \text{volume of one insufflation cycle}$), or as minute volume ($MV = TV \cdot CpM$). In contrast to conventional ventilators, in JV gas volumes are not identical with the corresponding thoracic expansion. The resulting chest expansion is much smaller than the applied gas volumes, thus indicating that a considerable portion of the delivered gas amount caused only a "washout" of the airways. Only a small part of the gas is translated to alveolar ventilation.^{9, 10} Tidal and minute volumes are resulting parameters, which vary depending on multiple factors. The gas volumes are directly influenced by WP and ID, as well as by the geometry of gas-carrying components and the airway. An increase in WP results in higher TV and MV, but as usual in JV this relationship is not linear because of the complex interaction of multiple factors.

Airway Pressure

The airway pressure (P_{aw}) is a resulting parameter that is mainly influenced by WP and to a lesser extent by other factors. As long as no obstacle to the gas outflow exists, the P_{aw} remains very low in the magnitude of a only few millibar. CpM and ID have little direct impact on the P_{aw} , except in extreme settings when it comes to remarkable changes in gas volumes. Additional factors such as size and shape of the tubing and the airway geometry are involved.¹¹ Since high P_{aw} directly bears the risk of barotrauma, a continuous measurement of P_{aw} is required, as well an automatic shutdown feature of the jet ventilator if set pressure limit is exceeded.¹² A state-of-the-art jet ventilator is additionally equipped with a second P_{aw} -monitoring line that can be connected to a separate lumen of the jet catheter. Through this special line, the P_{aw} is

continuously measured and displayed as a pressure curve indicating its determinants such as peak inspiratory pressure (PIP), mean airway pressure (mPaw) and endexpiratory pressure (EEP). In any case, the pressure is also measured in the jet tube, which however is only possible during the short break between the insufflations. Here, another alarm limit may be installed (break pressure), which needs to be undercut during each cycle so that the next insufflation will be released. With these provisions, jet ventilation is very safe in the context of avoiding lung injury, although the device operates with far higher WP than conventional ventilation. From strictly scientific point of view, one has to admit that the Paw in the trachea as measured with the ventilator's sensors is not identical to the airway pressures in various portions of the lung, but may be accepted as a good approximation. This can be used to activate the necessary alarms and to obey the pressure limits set by the user.

References

- 1 Takahashi H, Takezawa J, Nishijima MK, *et al.* Effects of driving pressure and respiratory rate on airway pressure and PaCO₂ in rabbits during high-frequency jet ventilation. *Crit Care Med* 1985; **13**: 728-732.
- 2 Aloy A and Schragl E. *Jet-Ventilation. Technische Grundlagen und klinische Anwendungen.* Wien New York: Springer, 1995.
- 3 Young JD. Gas movement during jet ventilation. *Acta Anaesthesiol Scand* 1989; **33 Suppl. 90**: 72-74.
- 4 Myles PS, Evans AB, Madder H and Weeks AM. Dynamic hyperinflation: comparison of jet ventilation versus conventional ventilation in patients with severe end-stage obstructive lung disease. *Anaesth Intens Care* 1997; **25**: 471-475.
- 5 Guenard H, Cros AM and Boundey C. Variations in flow and intraalveolar pressure during jet ventilation: theoretical and experimental analysis. *Resp Physiol* 1989; **75**: 235-245.
- 6 Biro P and Wiedemann K. Jet ventilation and anaesthesia for diagnostic and therapeutic interventions of the airway. *Anaesthesist* 1999; **48**: 669-685.
- 7 Dhar V, Young K, Nouraei SA, *et al.* Impact of oxygen concentration and laser power on occurrence of intraluminal fires during shared-airway surgery: an investigation. *J Laryngol Otol* 2008; **122**: 1335-1338.
- 8 Juri O, Frochoux D, Rajan GP and Biro P. Ignition and burning of biological tissue under simulated CO₂-laser surgery conditions. *Anaesthesist* 2006; **55**: 541-546.
- 9 Gaughan SD, Ozaki GT and Benumof JL. A comparison in a lung model of low- and high-flow regulators for transtracheal jet ventilation. *Anesthesiology* 1992; **77**: 189-199.

- 10 Lichtwarck-Aschoff M, Zimmermann GJ and Erhardt W. Reduced CO₂-elimination during combined high-frequency ventilation compared to conventional pressure-controlled ventilation in surfactant-deficient piglets. *Acta Anaesthesiol Scand* 1998; **42**: 335-342.
- 11 van Vught AJ, Versprille A and Jansen JRC. Alveolar pressure during high-frequency jet ventilation. *Intens Care Med* 1990; **16**: 33-40.
- 12 Biro P and Schmid S. Anesthesia and high frequency jet ventilation (HFJV) for surgical interventions on the larynx and trachea. *HNO* 1997; **45**: 43-52.

Driving gas conditioning in jet ventilation

P. Biro, University Hospital Zurich, Switzerland

Peter.biro@usz.ch

Ventilation with dry and cold gas may cause damage to the mucosa of the respiratory tract.¹ Mucosal damage may lead to temporary disturbance of muco-ciliary clearance, or to more severe morbidity related pneumonia or even to life-threatening conditions such as a necrotizing tracheo-bronchitis.² The involved factors in the etiology of these complications are:

1. exposure time to unconditioned gas during ventilation
2. hemodynamic instability
3. direct physical pressure on the mucosa
4. pre-existing damage of the mucosa as is in case of cigarette smoking- history.

Unfortunately it became a widespread habit among jet ventilation users to define shorter ventilation durations as “safe” in the context of ventilating without gas conditioning. Most popular estimates for this time period are < 30 or 45 minutes. It has to be emphasized, that such assumptions are not evidence based and reflect only the personal views or desires of those users, who don’t have a gas conditioning unit but would like to justify their use of JV. It’s however natural, that the longer the intervention lasts, the more problems would occur with unconditioned JV. But due to the multi-factorial origin of the resulting airway complications, a safe time period cannot be defined at all. Since even shorter procedures under JV without gas conditioning cause clinically relevant hypothermia, the only reasonable attitude in this context is that gas conditioning should be always implemented, independently of the duration or type of JV. Hypothermia is an unavoidable consequence of unconditioned gas ventilation due to the fact that large gas portions between 20 and 30 l/min are injected into the immediate vicinity of the large thoracic vessels, which in this case represent an efficient heat exchanger. Within 10 to 15 minutes of unconditioned JV, a decrease in body temperature of more than 2°C has to be expected.³

To create a well conditioned gas for JV means to warm up the gas to body temperature (37°C) and to enrich it with 100% relative humidity⁴. Neither warming of dry gas, nor simply adding water to unheated gas can achieve this requirement;

warming and moistening must go hand in hand in a coordinated mode ^{5,6}. For doing so, certain physical properties and limitations have to be taken into account. As pressure dramatically drops when the gas stream leaves the jet nozzle, the evicted gas expands and cools down by losing energy. This causes condensation of the transported humidity. The maximally possible water content of gas is temperature dependent. At body temperature, ventilation gas can contain 44 mg/l thus representing 100% relative humidity. When the gas cools down to ambient air temperature (22°C), the maximum capacity to carry water at 100% relative humidity drops to 19 mg/l. Therefore, whenever the temperature of the gas decreases – which unavoidably happens in the delivery system of jet ventilators of any kind – condensation of water occurs. This leads to formation of water droplets that are injected with the otherwise humidified gas into the airway. This water is rapidly absorbed and represents on the long run nothing else than an unwanted infusion of free water. This has to be considered in long term jet ventilation and even more in children as a potential cause for hyperhydration, disturbance of the osmotic balance and hyponatremia ⁶.

In modern jet ventilators, gas conditioning is provided by generating steam that is added to the jet gas. Therefore in the device the gas temperature comes close to 100°C and is saturated with water. Along the jet line which has a predetermined length, the temperature of the gas decreases to exactly 37°C, which causes the condensation of some part of the humidity. The relative humidity remains at 100%. This not really ideal from physiological point of view, but probably the best one can physically achieve ^{7,8}. An inbuilt microprocessor calculates the right amount of water that has to be vaporized to the actually delivered gas amount. The user of the device can operate an overall gas conditioning level ranging from 0 to 100%, but he cannot define the amount of water or the heat level separately. Considering the goal of always applying as much conditioning as possible, the default setting should be at 100% ⁹. However, in certain cases, a lower setting might be necessary. This is the case, when the operator is using an operation microscope and its lenses or mirror would become fogged by the exhaled humid gas. In this case, the conditioning level should be lowered as much as necessary and as little as possible.

Finally, conditioning of the delivered gas during JV is not an additional feature that might be applied or not according to availability of equipment or preferences of users; it

is a mandatory prerequisite for safe and time-unlimited application of this ventilation mode. The level of conditioning should be adjusted according the principle: as much as possible and as low as necessary. Contemporary equipment enables simple assembling and easy use of gas conditioning whenever JV is executed, in particular if a jet ventilator is used which automatically adjusts the water and energy supply to the actual ventilation settings.

References

- 1 Dias NH, Martins RH, Braz JR and Carvalho LR. Larynx and cervical trachea in humidification and heating of inhaled gases. *Ann Otol Rhinol Laryngol* 2005; **114**: 411-415.
- 2 Doyle HJ, Napolitano AE, Lippmann HR, *et al.* Different humidification systems for high-frequency jet-ventilation. *Crit Care Med* 1984; **12**: 815-819.
- 3 Biro P and Schmid S. Anesthesia and high frequency jet ventilation (HFJV) for surgical interventions on the larynx and trachea. *HNO* 1997; **45**: 43-52.
- 4 Chatburn RL and McClellan LD. A heat and humidification system for high frequency jet ventilation. *Respir Care* 1982; **27**: 1386-1391.
- 5 Sottiaux TM. Consequences of under- and over-humidification. *Respir Care Clin N Am* 2006; **12**: 233-252.
- 6 Williams RB. The effects of excessive humidity. *Respir Care Clin N Am* 1998; **4**: 215-228.
- 7 Biro P and Wiedemann K. Jet ventilation and anaesthesia for diagnostic and therapeutic interventions of the airway. *Anaesthetist* 1999; **48**: 669-685.
- 8 Kraincuk P, Kepka A, Ihra G, Schabernig C and Aloy A. A new prototype of an electronic jet-ventilator and its humidification system. *Crit Care* 1999; **3**: 101-110.
- 9 Schulze A. Respiratory gas conditioning and humidification. *Clin Perinatol* 2007; **34**: 19-33.

Monitoring during jet ventilaton

Markku Paloheimo

Clinius Oy, Espoo, Finland

markku.paloheimo@clinius.fi

Private address:

Fytgårdintie 34, 10140 Päivölä, Finland

markku.paloheimo@gmail.com

Tel: +358 400 424 566

The purpose of this chapter is to review monitoring methods and their information value during jet ventilation for laryngeal and tracheal surgery with laser techniques. CO₂ laser for excisional surgery in the airway is generally done via an operating laryngoscope equipped with supraglottic or subglottic small-bore tube or tubes to deliver jet streams of inspiratory gas mixed with air using a variety of frequencies (20 to >300 /min). This results in repeated pressure increases in the trachea and thus provides alveolar ventilation. For special cases, percutaneous transtracheal jet ventilation is used ¹.

Providing safe anaesthesia and maintaining oxygenation and sufficient ventilation during surgical laser procedures in the airway is more like art for the anaesthesiologist. Aside from administering sufficient anaesthesia/analgesia one has to provide the surgeon with maximally unobstructed view of the laryngeal surgical field while preventing complications (most significantly airway fires) during the fragile process ². Modern monitoring methods measure gas concentrations in the inspiratory and expiratory gas streams thus providing the facilities for safe oxygenation and normal carbon dioxide homeostasis ^{3,4}. Transcutaneous carbon dioxide monitoring may or may not be useful ^{5,6}. Pulse oximetry has routinely been used to confirm satisfactory oxygenation of peripheral arterial blood, which depends heavily on alveolar oxygen concentration enriched by various modes of jet ventilation ⁷.

Vocal cords and trachea are highly irritable during manipulations with the laser devices so that the patient must be adequately anaesthetized and ample amounts of analgetics must be administered to suppress autonomic responses, coughing and laryngeal spasms that interfere with surgery and may endanger the patient's well being⁸.

Neuromuscular block may be necessary to ensure immobilization of the surgical field even if this may prolong the recovery from anaesthesia.

Gas sampling for side-stream capnometry is straightforward – a metallic tube or needle is placed into the trachea either through the operating laryngoscope or transtracheally and connected to the gas analyzer. Many gas monitors can measure oxygen simultaneously from the same sample. During high frequency ventilation, the inspired and expired gases mix and the measured value gives a weighed average of gas concentrations. This can be avoided by decreasing the jet frequency intermittently to 20 /min or less so that a good expiratory tidal volume and its end-tidal values can be obtained ^{3,10}. Some jet ventilators can be programmed to give one larger tidal volume every minute or a dual system can be used with two separate jet streams with high and low frequencies superimposed and controlled electronically by solenoid valves ¹¹. Combined jet frequencies have been described having monitoring tubes for gas sampling and pressure monitoring ^{2,4}.

Normoventilation means alveolar ventilation which maintains the carbon dioxide level at around 4.0 kPa or 5,3 %. Anaesthesia is associated with respiratory depression, mainly due to opioids. Abnormally high ETCO₂ levels can be seen also during clinically sufficient inhalational anaesthesia during spontaneous breathing. Permissible hypercarbia states, that an acutely higher than normal carbon dioxide concentration is not harmful for the patient if kept below 80 kPa, above which carbon dioxide narcosis may follow ¹². End-tidal carbon dioxide is a good indicator of the overall carbon dioxide concentration and has good correlation with arterial P_aCO₂-values ^{13,14}.

The oxygen content of the gas has to be adjusted to facilitate alveolar oxygenation and kept low enough to prevent fires caused by the CO₂ laser igniting non-metal tubes, cannulaes or coal resulting from tissue destruction. Monitoring of expired alveolar oxygen concentration forms the basis of adjusting oxygen of the inspired oxygen fraction enabling fine adjustment of a satisfactory pulse oximetry reading. Arterial blood gas analyses (PaO₂, PaCO₂ and arterial oxygen saturation) are invasive procedures and are impractical to be done routinely. Expiratory gas concentrations and

pulse oximetry provide satisfactory data on the effect and quality of ventilation and oxygenation⁷.

Barotrauma. During high frequency jet ventilation (HFJV), it seems the pressures involved are the main hazard to the patient and, therefore, airway pressure monitoring is essential in the prevention of barotraumas. Tidal volumes increase with driving pressure while airway pressure only increases when tidal volume exceeds some 25 ml/kg¹⁵. It is fundamental to ensure adequate expiratory airflow during HFJV in order to protect the airway from inherent auto-PEEP effect¹⁵. Double lumen tubes for jet and monitoring of gas concentrations and pressures, either inserted through the pharynx or transtracheally seem a useful idea. Transtracheal pressure monitoring enables also gas sampling for analysis.

Neuromuscular block is often necessary to prevent vocal cord movement during surgical procedures. Conventional monitoring using a nerve stimulator and a method for objective determination of train-of-four responses aid in adequate timing and safe recovery of the block. The author's experience is that one or two residual responses to TOF keep the surgeon happy. The use of rocuronium and the new reversal drug, sugammadex provide optimal immobility and prompt recovery of muscle power.

Anaesthetic adequacy. There are methods to determine adequate levels of anaesthesia and analgesia. BIS and State entropy (SE) are EEG-derived indices measuring the anaesthetic effect of the applied hypnotic on EEG^{16,17}. Response entropy (RE) reflects the activation of the frontal mimic muscles caused by pain. Electromyographic activation may interfere with the EEG signal and lead into erroneously high SE values. The remedy for this is not additional hypnotic, but a moderate dose of opioids to abolish the mimic muscle activation and to reveal the correct SE.

Autonomic nervous balance. Another new parameter is the Autonomic Nervous System State (ANSS), which is a product of plethysmographic pulse peak interval (s) and plethysmographic pulse amplitude (%)¹⁸. The Autonomic Nervous System spot displays the pulse amplitude on Y-axis and pulse interval on the X-axis beat by beat¹⁸. Laryngeal or tracheal irritation causes autonomic responses that are readily detected by ANSS and suggest a need of additional opioids to be administered.

In conclusion, the jet ventilation techniques instead of conventional endotracheal tubes offer binocular vision through the operating microscope, excellent hemostasis and a clear line of demarcation of tissue destruction. In the light of gas monitoring, using high ventilation frequencies seems unnecessary, since it is possible to maintain adequate oxygenation and ventilation with moderate frequencies without compromising the laryngeal surgical field ². Monitoring of airway gas concentrations during less frequent breaths is easier and more accurate and is associated with fewer complications ¹⁹.

References

1. Preussler N-P, Schreiber T, Hüter L, Gottschall R, Schubert H, Rek H, Karzai W, Schwarzkopf K. Percutaneous transtracheal ventilation: effects of a new oxygen flow modulator on oxygenation and ventilation in pigs compared with a hand triggered emergency jet ventilator. *Resuscitation* 2003; 56: 329-33.
2. Borland L. Airway management for laser surgery on the larynx: Venturi jet ventilation and alternatives. *Int Anaesth clinics* 1977; 35: 99-105
3. Klein U, Karzai W, Gottschall R. Capnography during jet ventilation. *Acta Anaesth Scand* 1998; 42: 273-4
4. Klein U, Karzai W, Gottschall R, Gugel M, Bartel M. Respiratory gas monitoring during high-frequency jet ventilation for tracheal resection using a double lumen jet catheter. *Anesth Analg* 1999; 88: 224-6.
5. Berkenbosch J, Tobias J. Transcutaneous carbon dioxide monitoring during high-frequency oscillatory ventilation in infants and children. *Crit Care Med* 2002; 30: 1024-27.
6. Simon M, Gottschall R, Gugel H, Fritz H, Mohr S, Klein U. Comparison of transcutaneous and end-tidal CO₂-monitoring for rigid bronchoscopy during high-frequency jet ventilation. *Acta Anaesth Scand* 2003; 47: 861-7.
7. Baer GA, Paloheimo M, Rahnasto J, Pukander J. End-tidal oxygen concentration and pulse oxymetry for monitoring oxygenation during intratracheal jet ventilation. *J Clin Monit* 1995; 11: 373-80.
8. Paloheimo M, Sahanne S, Uutela KH. Autonomic nervous system state: the effect of general anaesthesia and bilateral tonsillectomy after unilateral infiltration of lidocaine. *Br J Anaesth* 2010; 104: 587-95.
9. Frietsch T, Krafft P, Becker HD, Buelzebruck H, Wiedermann K. Intermittent capnography during high-frequency jet ventilation for prolonged rigid bronchoscopy. *Acta Anaesth Scand* 2000; 44:391-7.

10. Ihra G, Hieber C, Schabernig C, Kraincuk P, Adel S, Plöchl W, Aloiy A. Supralaryngeal tubeless combined high-frequency jet ventilation for laser surgery of the larynx and trachea. *Brit J Anaesth* 1999; 83: 940-2.
11. Bacher A, Pichler K, Aloy A. Supraglottic combined frequency jet ventilation versus subglottic monofrequent jet ventilation in patients undergoing microlaryngeal surgery. *Anesth Analg* 2000; 90: 460-5.
12. Kety S, Schmidt C; The effects of altered arterial tensions of carbon dioxide and oxygen on cerebral blood flow and cerebral oxygen consumption of normal young men. *J Clin Invest* 1948; 27: 484-92.
13. Algora-Weber A, Rubio J, de Villota E, Cortes J, Gomez D, Mosquera J. Simple and accurate monitoring of end-tidal carbon dioxide tensions during high frequency jet ventilation. *Crit Care Med* 1986; 14: 895-7.
14. Carlon G, Ray C, Griffin J, Midownik S, Groeger J. Tidal volume and airway pressure on high frequency jet ventilation. *Crit Care Med* 1984; 12: 180-2.
15. Evans K, Keene M, Bristow A. High-frequency jet ventilation, a review of its role in laryngology. *J Laryngol Otol* 1994; 108: 23-5.
16. Schmidt G, Bischoff P, Standl T, Hellstern A, Teuber O, Schulte am Esch J. Comparative evaluation of the Datex-Ohmeda S/5 Entropy module and the Bispectral Index(R) monitor during propofol-remifentanyl anesthesia. *Anesthesiology* 2004; 101: 1283-90.
17. Vanluchene A, Struys M, Heyse B, Mprtier E. Spectral entropy measurement of patient responsiveness during propofol and remifentanyl. A comparison with the bispectral index. *Brit J Anaesth* 2004; 93: 645-54.
18. Paloheimo M, Sahanne S, Uutela K. Autonomic nervous system state: the effect of general anaesthesia and bilateral tonsillectomy after unilateral infiltration of lidocaine. *Brit J Anaesth* 2010; 104: 587-95.
19. Jaquet Y, Monnier P, van Melle G, Ravussin P, Spahn D, Chollet-Rivier M. Complications of different strategies in endoscopic laryngeal surgery. *Anesthesiology* 2006; 104: 52-9.

Safe Jet Ventilation

Gerhard A. Baer, MD, PhD,
Department of Anaesthesiology
University of Tampere, School of Medicine
33014 Tampere, Finland
Gerhard.baer@dnainternet.net

A complication is the manifestation of a known or unknown risk. Knowing risks and acting appropriately improves safety. However, complication-free acting is impossible. Therefore, safe acting inheres being prepared to treat complications. There are specific risks and possible complications for the different modes of jet ventilation.

Risks

The ejector formed by a rigid bronchoscope and a jet provides always the same airway pressure when a certain driving gas pressure is applied ¹. Unnoticed occlusion of the expiratory airway is impossible. There are no reports of barotrauma with this mode of jet ventilation in adult patients. However, settings of a jet safe in an adult bronchoscope may cause extremely high pressures in paediatric size broncho-scopes.

Jet ventilation through a channel of a fiberbronchoscope inheres a high risk of barotrauma. Once the bronchoscope occludes a bronchus (wedging) most certainly barotrauma will occur.

Transcutaneous intratracheal jet ventilation ² inheres the highest complication rate ⁶: there is the risk common to all kinds of intratracheal jet ventilation, i.e., barotrauma due to occlusion of the expiratory airway. Additionally, the transdermal cannula easily slips out of the trachea. Then, depending on its location between tracheal wall and skin, the next jet blow will cause more or less local surgical emphysema, which may cause serious problems.

Translaryngeal intratracheal jet ventilation ⁴ avoids the risks of tracheal puncture. Like with all kinds of tracheal intubation, the jet catheter may be displaced. However, one blow of the jet into the oesophagus may cause gastric rupture. Occlusion of the expiratory airway will immediately cause barotrauma. - Shape and size of the trachea and the position of a simple jet catheter inside the trachea are normally unknown; these three parameters influence the performance of the ejector formed by the jet and the trachea ²⁵. Thus, airway pressure cannot be deduced from driving gas pressure. A catheter not fixed to the centre of the trachea may blow onto the mucosa.

The dry and cold jet certainly causes local spots of mucosal anaemia; no squeals are published. On the general consequences of dry gas jet ventilation see Biro²⁶.

Supraglottic jet ventilation, the "ventilating laryngoscope"²⁷, avoids the risk of expiratory airway occlusion. It inheres the risk of debris seed, as noted by its pioneers^{3;27} and smoke inhalation into the tracheo-bronchial system, which have been mentioned also later^{28 29 30 31}; complications have been rarely published³². To ventilate and oxygenate his patient, the anaesthesiologist depends on the skills of the endoscopist, which may cause difficulties in teaching hospitals³³.

All inflammable material may explode in pure oxygen. Most catheters used for jet ventilation consist of inflammable material. Additionally, the laser beam may form coal out of tissue or tissue particles (smoke)³⁴. Therefore, during airway laser surgery, the oxygen concentration in the airway should be kept as low as possible (< 30% as a rule) and flammable material avoided⁹.

In order to minimize vocal cord movements during endolaryngeal surgery, high frequency jet ventilation was introduced³⁵. With intratracheal use, the inherent PEEP effect may prevent aspiration³⁶, but may also cause barotrauma. Superimposed high frequency jet ventilation compensates for the occasionally seen insufficient ventilation with ventilation at high frequencies³⁷.

Complications

Table 1 gives an overview on complications (pneumothorax and tissue emphysema) published in relation to a certain patient population. Case reports of complications are numerous during the first decade of jet ventilation. The table depicts the same correlation as recently found in a review on jet ventilation³⁸: the complication rate is inversely related to experience. Neglecting basic safety rules is the main reason for complications.

Safety

The **equipment should be familiar** from own experience before approaching a patient¹. In most hospitals, there is a plethora of equipment particles from different manufacturers and different series.

Manipulations in the airway may always result in airway occlusion. Therefore, pre-oxygenation and pure **oxygen** as driving gas, when not contraindicated, are recommended. The **expiratory airway** has to be **secure**.

Table 1 Complications (pneumothorax and tissue emphysema) with jet ventilation

Source	N	A/P	Mode	Compl.%	Centre
RossAnderson2011	50	A	TTHFJV	0	single
Davies2009	552	A	TLJV	0	single
Jaquet2006	265	A	TTJV	2.26	single
Jaquet2006	469	A	TLJV	0.2	single
Gulleth2005	33	A	TTJV	6.06	single
Bourgain2001	643	A	TTHFJV	10.3	multi
Russel2000	90	A	TTHFJV	2.22	single
Depierraz1994	28	P	TTJV	7.14	single
Chang1980	600	A	TLJV	0.5	single
1971 –1975 *	104	A	TTJV	7.69	multi
1973-1981 *	367	A	TLJV	1.64	multi

* Summary of three different publications ³⁹.

Explanations: A/P: adult(paediatric).

TTHFJV: trans-tracheal high-frequency jet ventilation

TTJV: trans-tracheal jet ventilation

TLJV: trans-laryngeal jet ventilation.

Centre: single: single centre study. multi: multi-centre study

One can never be absolutely sure, that the jet catheter is where it should be, that the trachea is of normal size and shape or that the ventilating laryngoscope is in the right position. Therefore, **jet ventilation begins at driving gas pressure zero.**

Driving gas pressure is slowly increased. One finger is ready on the “stop” button. Without monitoring equipment, observation of respiratory movements is the only way to monitor ventilation. Auscultation is useless because it mediates only the noise of the jet, whether it is blowing into the trachea, into the oesophagus or somewhere into the tissue. The jet operator should know at what driving pressure to expect first respiratory movements (respiratory inductance plethysmography via elastic bands⁴⁰ or impedance pneumography may soon become useful tools), a rising airway pressure or when end tidal carbon dioxide should appear. If these signs do not appear in time, it is better to stop and to look for the reason of malfunction. Phonation and coughing or attempts thereof should cause an immediate stop (insufficient anaesthesia, insufficient muscle relaxation).

With intratracheal jet ventilation, **airway pressure monitoring**⁴¹ is mandatory because of the uncertainties about the performance of the individual jet pump formed by the jet catheter and the patient’s trachea⁴². A “safe overdose” of succinylcholine⁵ may be sufficient to **avoid active glottic closure**. A method warning in time of possible glottic closure (insufficient muscle relaxation) might be preferable. Attempts to cough

or of weak phonation are observable without special equipment. Pressure curve monitoring has been suggested ⁴³, watching for movements of the vocal cords on the video chain monitor ⁴⁴ is possible in all well-equipped institutions. Keeping TOFF below zero is not sufficient, a post tetanic count at maximum of two is recommended ⁴⁵. An **automatic cut-off** at a certain pressure is **mandatory with HFJV** ⁷ because several blows have happened before an observer reacts to increasing airway pressure; such automatic is incorporated in all modern jet ventilators.

Transtracheal jet ventilation should be reserved for special cases ⁶ and should be performed by experienced teams only^{38;46}. For use in emergencies see Janjevic ⁴⁷.

In experienced centres, there are no difficulties and no complications with supraglottic jet ventilation ²⁸. During laser surgery, smoke is blown into the trachea. However, there are no controlled randomised trials suggesting, which risk to prefer: smoke inhalation and possible debris seeding with supraglottic jet ventilation or the risk of (avoidable) barotrauma with intratracheal jet ventilation ⁴⁸.

Only with supraglottic jet ventilation all possibly ignitable material, except burnt tissue, is out of reach of the laser beam. A second choice has been use of soft copper tubes as intratracheal jet pipes see Pukander2011 ⁴⁹. According to clinical experience, a fluoroplastic self-centering tube is as safe ⁵⁰ and softer; it will not burn, but may be badly deformed by the laser beam ⁵¹ - Laser surgery during jet ventilation can also be safely performed in patients with impaired lung function (COPD, obesity): Monitoring end tidal oxygen concentration enables to keep safely longer periods of low inspiratory oxygen concentration than when monitoring oxygen saturation ⁵².

Equipment and skill to treat all possible complications is an essential of all safe anaesthesia. Treating complications should never become a routine; therefore, perpetual training is mandatory. After starting to repeat regularly one-hour resuscitation training at three months intervals, resuscitating, seen previously once a year, became absent for the next 6 years in our department (about 3000 cases of ENT surgery, 120 endolaryngeal procedures per year).

To summarise: following established safety rules, relying on experience, and being prepared to treat complications are the keystones of safe jet ventilation.

Reference List

1. Sanders RD: Two ventilating attachments for bronchoscopes. Delaware M J 1967; 39: 170-5, 192

2. Spoerel WE, Narayanan PS, Singh NP: Transtracheal ventilation. *Br J Anaesth* 1971; 43: 932-9
3. Smith RB, Schaer WB, Pfaeffle H: Percutaneous transtracheal ventilation for anaesthesia and resuscitation: a review and report of complications. *Can Anaesth Soc J* 1975; 22: 607-12
4. Spoerel WE, Greenway RE: Technique of ventilation during endolaryngeal surgery under general anaesthesia. *Can Anaesth Soc J* 1973; 20: 369-77
5. Baer GA: [Effect of various tracheal diameter forms on airway pressure in experimental intratracheal injector ventilation]. [German]. *Anaesthesist* 1985; 34: 124-8
6. Biro P: Driving Gas Conditioning in Jet Ventilation, *Joined Papers on Jet Ventilation*. Edited by Baer GA. Tampere, Tampere University Press, 2011,
7. Oulton JL, Donald DM: A ventilating laryngoscope. *Anesthesiology* 1971; 35: 540-2
8. Barr NL, Itscoitz S, Chan.C., Economopoulos B, Albert SN: Oxygen injection in suspension laryngoscopy. *Arch Otolaryngol* 1971; 93: 606-9
9. Rezaie-Majd A, Bigenzahn W, Denk DM, Burian M, Kornfehl J, Grasl MC, Ihra G, Aloy A: Superimposed high-frequency jet ventilation (SHFJV) for endoscopic laryngotracheal surgery in more than 1500 patients. *Br J Anaesth* 2006; 96: 650-9
10. Cook TM, Asif M, Sim R, Waldron J: Use of a ProSeal laryngeal mask airway and a Ravussin cricothyroidotomy needle in the management of laryngeal and subglottic stenosis causing upper airway obstruction. *Br J Anaesth* 2005; 95: 554-7
11. Strashnov VI, Pluzhnikov MS, Kolotilov LV, Gir EE, Ouchvatkina MK: High-frequency jet ventilation in endolaryngeal surgery. *J.Clin.Anesth.* 1995; 7: 19-25
12. Evans KL, Keene MH, Bristow AS: High-frequency jet ventilation--a review of its role in laryngology. *J.Laryngol.Otol.* 1994; 108: 23-5
13. Oliverio R, Jr., Ruder CB, Fermon C, Cura A: Pneumothorax secondary to ball-valve obstruction during jet ventilation. *Anesthesiology* 1979; 51: 255-6
14. El-Naggar M, Keh E, Stemmers A, Collins VJ: Jet ventilation for microlaryngoscopic procedures. A further simplified technique. *Middle East J Anaesthesiol.* 1974; 4: 5-16
15. Juri O, Frochoux D, Rajan GP, Biro P: [Ignition and burning of biological tissue under simulated CO₂-laser surgery conditions]. *Anaesthesist* 2006; 55: 541-6
16. Ossoff RH: Laser safety in otolaryngology - head and neck surgery: anesthetic and educational considerations for laryngeal surgery. *Laryngoscope* 1989; 99: 1-26
17. Klain M, Smith RB: High frequency percutaneous transtracheal jet ventilation. *Crit Care Med* 1977; 5(6): 280-7
18. Klain M, Keszler H, Stool S: Transtracheal high frequency jet ventilation prevents aspiration. *Crit Care Med* 1983; 11: 170-2
19. Aloy A, Schachner M, Spiss CK, Cancura W: [Tube-free translaryngeal superposed jet ventilation]. [German]. *Anaesthesist* 1990; 39: 493-8
20. Cook TM, Alexander R: Major complications during anaesthesia for elective laryngeal surgery in the UK: a national survey of the use of high-pressure source ventilation. *Br J Anaesth* 2008; 101: 266-72

21. Baer, G. A. Intratracheal jet ventilation for endolaryngeal procedures. Acta Universitatis Tamperensis 187, ISBN 951-44-1699-6. 1985.
Ref Type: Thesis/Dissertation
22. Atkins JH, Mirza N, Mandel JE: Case report: respiratory inductance plethysmography as a monitor of ventilation during laser ablation and balloon dilatation of subglottic tracheal stenosis. ORL J Otorhinolaryngol.Relat Spec. 2009; 71: 289-91
23. Heifetz M, DeMyttenaere S, Rosenberg B: Intermittent positive pressure inflation during microscopic endolaryngeal surgery. Anaesthesist 1977; 26: 11-4
24. Baer GA: Die Wirkung verschiedener Tracheaquerschnittsformen auf den Atemwegsdruck bei experimenteller intratrachealer Injektorventilation. Anaesthesist 1985; 34: 124-8
25. Carden E, Crutchfield W: Anaesthesia for microsurgery of the larynx (A new method). Can Anaesth Soc J 1973; 20: 378-89
26. Baer GA: Laryngeal muscle recovery after suxamethonium. Detection during intratracheal jet ventilation by pressure curve monitoring. Anaesthesia 1984; 39: 143-6
27. Vaughan, Charles C. Operation microscope video chain for monitoring of deep muscle relaxation during endolaryngeal procedures. 1985.
Ref Type: Personal Communication
28. Puura AI, Rorarius MG, Manninen P, Hoppu S, Baer GA: The costs of intense neuromuscular block for anesthesia during endolaryngeal procedures due to waiting time. Anesthesia & Analgesia 1999; 88: 1335-9
29. Klain M, Smith RB: Fluidic technology. A discussion and a description of a fluidic controlled ventilator for use with high flow oxygen techniques. Anaesthesia 1976; 31: 750-7
30. Bourgain JL, Chollet M, Fischler M, Gueret G, Mayne A: [Guide for the use of jet-ventilation during ENT and oral surgery]. Ann.Fr.Anesth Reanim. 2010; 29: 720-7
31. Janjevic D: Jet Ventilation for Difficult Intubations and Emergencies, Joined Papers on Jet Ventilation. Edited by Baer GA. Tampere, Tampere University Press, 2011,
32. Baer GA: What to prefer during jet ventilation for endolaryngeal procedures, risk of barotrauma or of aspiration of contaminating material? Anesthesia & Analgesia 2001; 93: 1625
33. Pukander J: Jet Ventilation and Laser for endolaryngeal procedures, Joined Papers on Jet Ventilation. Edited by Baer GA. Tampere, Tampere University Press, 2011,
34. Orloff LA, Parhizkar N, Ortiz E: The Hunsaker Mon-Jet ventilation tube for microlaryngeal surgery: optimal laryngeal exposure. Ear Nose Throat J 2002; 81: 390-4
35. Frochoux D, Rajan GP, Biro P: [Laser-resistance of a new jet ventilation catheter (LaserJet) under simulated clinical conditions]. Anaesthesist 2004; 53: 820-5
36. Baer GA, Paloheimo M, Rahnasto J, Pukander J: End-tidal oxygen concentration and pulse oximetry for monitoring oxygenation during intratracheal jet ventilation. Journal of Clinical Monitoring 1995; 11: 373-80

Endolaryngeal procedures: Conventional Intubation vs. Infra- and Supra-glottic Jet Ventilation.

Gerhard A. Baer, MD, PhD,

Department of Anaesthesiology, University of Tampere Medical School
Tampere, Finland Gerhard.Baer@dnainternet.net

Grasping a specimen out of the larynx under more or less local anaesthesia using benched forceps and a mirror became obsolete after introduction of laryngomicroscopy¹. General anaesthesia became necessary and a secured airway. Smaller and smaller intubation tubes were used but the competition in the airway between anaesthesiologists and laryngologists remained, until jet ventilation² was introduced for that purpose in three different modes:

- 1 transtracheal jet ventilation, where skin and trachea are punctured by the jet needle below the larynx³;
- 2 supraglottic jet ventilation, where the jet blows into the laryngoscope, which is tightly positioned to the larynx^{4;5};
- 3 translaryngeal (subglottic) jet ventilation, where a small catheter is introduced through the larynx into the trachea⁶.

Other possibilities to prevent any obstacles for the laryngologist are apnoeic oxygenation⁷ and negative pressure ventilation using a cuirass.

The purpose of this communication is to evaluate the benefits and drawbacks for the patient of the different possibilities to ventilate during endolaryngeal procedures. Unfortunately lack of randomised controlled trials turns this into a discussion of published and personal experience and opinions.

Working Conditions

The working conditions inside the patient's airway are obviously better with any kind of jet ventilation than with ventilation through conventional or even small-bore intubation tubes. Perhaps, therefore, there are almost no randomised controlled trials (RCT) comparing working conditions of different ventilation modes⁸. (*Medline 2010, jet ventilation AND randomised AND controlled*).

There are retrospective studies analysing a period when different modes of ventilation were used almost at random^{9 10} or alternatively for special procedures¹¹. Most publications on jet ventilation deal with experience with jet ventilation in case series without comparison to other ventilation modes^{12 13 14 15}.

Conclusions have been that working conditions with any mode of jet ventilation are better than with ventilation through conventional intubation tubes.

Very rarely procedure durations have been compared^{9;16}; durations are smaller with JV, but results are unreliable due to uneven distribution of different procedures and too small case numbers.

Complications

Complications with JV have been published as case reports and within case series and comprise barotrauma only. In a recent study on complications with different modes of ventilation for laryngomicroscopy in one institution during 10 years¹¹ the rank order of complications is similar as described in the pioneer years of jet ventilation¹⁷: Most severe complications relate to transtracheal jet ventilation, which, therefore, should be reserved for emergencies and special cases^{11, 17}; obstruction of the expiratory airway is the second important reason for complications with intermittent apnoeic ventilation¹¹ and transglottical JV^{9;11}. On the other hand, most of these complications are avoidable and their appearance is inversely related to performance numbers, i.e. the less experience the more complications¹⁸.

Some cases of unnoticed mucosal lesions have been published⁹. Their consequences in the worst case can only be imagined; there are no published cases. The possibility of debris aspiration has been discussed in the pioneer phase of jet ventilation^{4, 5} and recently^{19;20}, but there is no publication on debris aspiration.

Data of interest for patient and hospital owners

Estimation of working conditions has been by the ENT surgeon. However, working conditions are of no interest for patients and hospital owners without showing that “better conditions” means less suffering and decrease of expenses. They might be interested in

- duration of the procedure
- pain and sore throat after the procedure
- risks and complication rates
- frequency of wrong or missed diagnosis
- frequency of subsequently necessary additional procedures

in relation to the different ventilation methods.

Insurance companies may be additionally interested in duration of sick leave and frequency and costs of persistently cured patients. There are no studies published answering these questions.

Conclusions

Most certainly long-term results of endolaryngeal procedures performed under general anaesthesia are better with any form of jet ventilation (JV) than with conventional ventilation (CV) through intubation tubes. Procedures are shorter and sick leave may be shorter after JV than after CV. Complications with JV are avoidable when safety rules are followed, which is obviously easier in an experienced team than when doing occasional cases. Anaesthesiologists might prefer translaryngeal catheter JV because of their responsibility for ventilation and oxygenation; additionally, not even smoke during Laser surgery will enter the lungs^{21 22}. However, there is a lack of RCTs and comparing studies to prove these claims and to convince those not using jet ventilation.

Table 1

Conventional intubation or JV for endolaryngeal procedures:			
Aspect	Intubation	Intratracheal JV	Supraglottic JV
View	restricted	No problem	free
Working conditions	restricted	No problem	optimum
Gas Composition	Controlled	Controlled	Uncertain
Ventilatory Responsibility	Unique	Unique	Shared
Monitoring ⁴	Usual equipment	Special equipment	Special equipment
Barotrauma	Rare, avoidable	Frequent, avoidable	Possible
Tissue emphysema	Rare	Possible	Possible
Gastric inflation	Anaesth. dependent	Anaesth. dependent	Scopist-dependent
Debris seed	Impossible	Impossible ¹	Possible
Laser Surgery	Needs Special Equipment	Needs Special Equipment ³	No Problem
Worst scenario	Undetected Lesion	Barotrauma	Can't ventilate
"Sore Throat" ²	frequent	< frequent	<< frequent

1. There is a weak inflow for the first 1/8 of inspiration, thereafter persists a strong flow out of the glottis ²¹. See also Virtanen & Karvinen ²².
2. Sore throat correlates with size of p.o. observable mucosal lesions ²³; therefore, sore throat should appear in the indicated frequencies.
3. Non-inflammable jet catheters have been soft copper pipes ²⁴ or with less perfect resistance, made from polytetrapolyethylene ²⁵.
4. See Paloheimo ²⁶.

Reference List

1. Kleinsasser O: [A laryngomicroscope for the early diagnosis and differential diagnosis of cancers in the larynx, pharynx and mouth]. *Z.Laryngol.Rhinol.Otol.* 1961; 40: 276-9
2. Sanders RD: Two ventilating attachments for bronchoscopes. *Delaware M J* 1967; 39: 170-5, 192
3. Spoerel WE, Grant PA: Ventilation during bronchoscopy. *Can Anaesth Soc J* 1971; 18: 178-88
4. Oulton JL, Donald DM: A ventilating laryngoscope. *Anesthesiology* 1971; 35: 540-2
5. Barr NL, Itscoitz S, Chan.C., Economopoulos B, Albert SN: Oxygen injection in suspension laryngoscopy. *Arch Otolaryngol* 1971; 93: 606-9
6. Spoerel WE, Greenway RE: Technique of ventilation during endolaryngeal surgery under general anaesthesia. *Can Anaesth Soc J* 1973; 20: 369-77
7. Smith RB, Sjostrand UH: Apneic diffusion oxygenation and continuous flow apneic ventilation. A review. *Acta Anaesthesiol.Scand.* 1985; 29: 101-5

8. Patel A, Rubin JS: The difficult airway: the use of subglottic jet ventilation for laryngeal surgery. *Logoped.Phoniatr.Vocol.* 2008; 33: 22-4
9. Baer GA, Pukander J, Baer G, Eerola R, Kataja M: [Working conditions and complications during laryngomicroscopies under endotracheal ventilation via intubation tubes or injection ventilation]. [German] *Anaesthesist* 1982; 31: 621-4
10. Davies JM, Hillel AD, Maronian NC, Posner KL: The Hunsaker Mon-Jet tube with jet ventilation is effective for microlaryngeal surgery. *Can J Anaesth* 2009; 56: 284-90
11. Jaquet Y, Monnier P, Van MG, Ravussin P, Spahn DR, Chollet-Rivier M: Complications of different ventilation strategies in endoscopic laryngeal surgery: a 10-year review. *Anesthesiology* 2006; 104: 52-9
12. Ihra G, Hieber C, Adel S, Kashanipour A, Aloy A: Tubeless combined high-frequency jet ventilation for laryngotracheal laser surgery in paediatric anaesthesia. *Acta Anaesthesiol Scand* 2000; 44: 475-9
13. Smirnov AE, Klochikhin AL: [Maintenance of respiratory function during direct laryngoscopy in patients with laryngeal neoplasms]. *Vestn.Otorinolaringol.* 2010; 33-7
14. Barakate M, Maver E, Wotherspoon G, Havas T: Anaesthesia for microlaryngeal and laser laryngeal surgery: impact of subglottic jet ventilation. *J Laryngol.Otol.* 2010; 124: 641-5
15. Rubin JS, Patel A, Lennox P: Subglottic jet ventilation for suspension microlaryngoscopy. *J Voice* 2005; 19: 146-50
16. El-Naggar M, Keh E, Stemmers A, Collins VJ: Jet ventilation for microlaryngoscopic procedures: a further simplified technic. *Anesth Analg* 1974; 53: 797-804
17. Smith RB, Schaer WB, Pfaeffle H: Percutaneous transtracheal ventilation for anaesthesia and resuscitation: a review and report of complications. *Can Anaesth Soc J* 1975; 22: 607-12
18. Cook TM, Alexander R: Major complications during anaesthesia for elective laryngeal surgery in the UK: a national survey of the use of high-pressure source ventilation. *Br J Anaesth* 2008; 101: 266-72
19. Baer GA: What to prefer during jet ventilation for endolaryngeal procedures, risk of barotrauma or of aspiration of contaminating material? *Anesthesia & Analgesia* 2001; 93: 1625
20. Rezaie-Majd A, Bigenzahn W, Denk DM, Burian M, Kornfehl J, Grasl MC, Ihra G, Aloy A: Superimposed high-frequency jet ventilation (SHFJV) for endoscopic laryngotracheal surgery in more than 1500 patients. *Br J Anaesth* 2006; 96: 650-9
21. Baer, G. A. *Intratracheal jet ventilation for endolaryngeal procedures.* Acta Universitatis Tamperensis 187, ISBN 951-44-1699-6. 1985.
Ref Type: Thesis/Dissertation
22. Virtanen JK, Karvinen R: Technology of Jet Ventilation, *Joined Papers on Jet Ventilation.* Edited by Baer GA. Tampere, Tampere University Press, 2011, pp 6-18
23. Combes X, Schaulvliege F, Peyrouset O, Motamed C, Kirov K, Dhonneur G, Duvaldestin P: Intracuff pressure and tracheal morbidity: influence of filling with saline during nitrous oxide anesthesia. *Anesthesiology* 2001; 95: 1120-4
24. Pukander, J. and Baer, G. Non flammable copper jet ventilation tube in intralaryngeal laser surgery. Ribari, O. and Hirschberg, A. 363-367. 1996. Bologna, Monduzzi Editore S.p.A. EUFOS European Federation of Oto-Rhino-Laryngological societies. 6-9-1996.

25. Frochoux D, Rajan GP, Biro P: [Laser-resistance of a new jet ventilation catheter (LaserJet) under simulated clinical conditions]. *Anaesthetist* 2004; 53: 820-5
26. Paloheimo M: Monitoring during jet ventilation, *Joined Papers on Jet Ventilation*. Edited by Baer GA. Tampere, Tampere University Press, 2011, pp 27-31

20 Years of Experience with Normofrequent Subglottic/Intratracheal Jet Ventilation.

Jüri Samarütel, MD, PhD

University of Tartu, Estonia

Jyri.Samarytel@kliinikum.ee

HFJV with sophisticated equipment dominates in the recent literature about anaesthesia for endolaryngeal microsurgery. Despite their well-known drawbacks, supraglottic JV or JV via an invasive access to the subglottic space (transtracheal JV) are in use in leading centres. In Tartu JV was introduced in 1990¹ and has been used in ~ 2700 anaesthesias. In the first 200 cases patients were intubated with double lumen copper cannula (OD 2,2 mm). One lumen was used for monitoring intratracheal pressure. Through the other lumen, normofrequent JV (NJV) with 100% O₂ was applied using a hand-operated valve and pressure regulator. Alternatively, NJV/HFJV was applied using a home-made electronic ventilator².

Both methods provided full oxygenation and acceptable CO₂ removal for up to 140 minutes of anaesthesia. Therefore, preferring simplicity, the last ~ 2500 cases were managed with NJV and a hand-operated valve. The pressure monitoring line was removed, and ventilation was monitored observing chest movements and SpO₂. The 1,5 or 2,2 mm OD blunt single metal pipe provided the surgeon with good operating conditions, enabled use of laser, and provided unlimited time.

Anaesthetics were given intravenously in single doses in sufficient amounts to suppress motor responses to surgery. A muscle relaxant (Succinylcholine with antidepolarizer pre-treatment) was used only for intubation of the trachea. Introduction of the metal pipe and its alignment with the axis of the trachea was possible even in severely compromised airways. Exception are two cases of Ca laryngis, where the airway was established with a stiffer metal tube (pediatric bronchoscope).

JV began with about half of the intended final pressure. After confirmation of expiration, driving gas pressure was gradually increased (up to 3,5 bar in most adults). Ventilation was continued after the end of surgery until return of consciousness and muscle power.

Patients' age varied from 4 months to 91 yrs., BW was from 5,2 to 170 kg. Adipose or dyspneic patients were positioned with hips bent and upper body elevated. Despite one case of lethal barotrauma in a baby with tracheobronchomalacia and multiple anomalies, we consider our technique acceptable and continue its use for

management of various airway pathology. It is obviously safe, efficient, and inexpensive, the latter being important not only in Estonia.

Reference List

1. Baer, G. A. Intratracheal jet ventilation for endolaryngeal procedures. Acta Universitatis Tamperensis 187. 1985. ISBN 951-44-1699-6
2. Kull M, Samarütel J, Nurm V: Double frequency jet ventilation for endolaryngeal laser surgery. Lasers in Medical science 1993; 8: 141-6

JV and LASER for Endolaryngeal Procedures

J. Pukander MD

Professor of Otolaryngology

School of Medicine, University of Tampere, 33014 Tampere, Finland

juhani.pukander@uta.fi

Jet ventilation is one of the most important advances in anaesthetic techniques for endolaryngeal procedures because it provides the surgeon with free access to the larynx without any visual or mechanical obstruction by an endotracheal tube^{1;2}. The original jet ventilation method with the supraglottically situated jet device^{3;4} contains some disadvantages like possible gastric distension, vocal cord motion, mucosal dehydration and when using laser, smoke⁵ and debris can enter the tracheobronchial tree. All these disadvantages can be avoided by inserting the jet device inside the trachea^{6;7}. The jet can be delivered using a transdermal needle puncture to the trachea⁸, but this is recommendable only in few specialized cases and inheres a high risk of serious complications^{2;9;10}. Use of a translaryngeal jet catheter is another choice⁶. After the introduction of lasers in endolaryngeal microsurgery several types of non-flammable metal intubation tubes have been developed like the Norton¹ and Porch tube¹¹. But to provide an adequate inner diameter for ventilation, the outer diameter of the metal tubes is reasonably large obstructing the working conditions of the endoscopist. Intratracheal jet ventilation is associated with the risk of barotraumas, thus monitoring of intratracheal pressure is mandatory.

In our institution we have developed a double lumen copper tube where one channel delivers jet gas at high pressure for the injector, the other channel serving as a monitoring line. Soft copper stiffens, when bended, but may be softened again by heating; it does not reflect the laser beam, and does not melt at the energy used during endolaryngeal laser surgery. However, during laser surgery tissue is transformed into

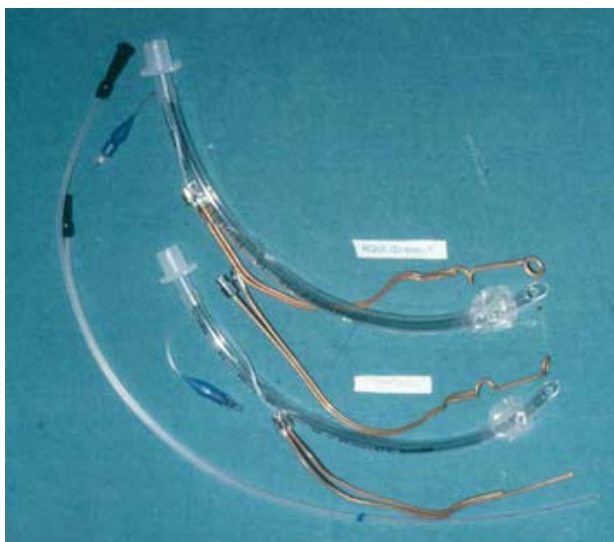

Fig. 1

Double lumen copper pipe for intratracheal jet ventilation.

Corresponding conventional intubation tubes and our plastic jet ventilation tube made from two suction catheters are added for comparison.

inflammable material¹²; therefore, airway oxygen concentration should be kept at 30% maximum¹³. At this level of oxygen concentration monitoring of end tidal oxygen enlarges the safety margin in patients with obesity or COPD¹⁴.

INSTRUMENTATION

The jet ventilation tube is made of two thin walled bendable copper pipes with the outer diameter (OD) of 2.5mm and inner diameter (ID) 1.8mm, respectively; this is the copper pipe closest in size to our plastic jet catheter system, self-made from two FG 10 suction catheters (ID 2.2mm). The tip of the injector line is in the centre of two coils formed by the monitoring line to centralize the jet inside the trachea (Fig.1). The proximal coil is 2cm, the distal 7cm below the vocal cords. The outer diameter of the coils matches the size of a 7 or 8mm ID tracheal tube. The distal coil is provided with small holes to monitor airway pressure during inspiration and alveolar gas concentration during expiration¹⁴.

The inserting technique of this metal tube is similar to normal endotracheal intubation and an experienced anaesthesiologist easily learns to bend the tube to the individual patient's need. Since this pioneer work in the 1990 's¹⁵ commercial products are nowadays available like the self-centralising¹⁶ Hunsaker Mon-Jet tube made from non-flammable fluoroplastic material¹⁷.

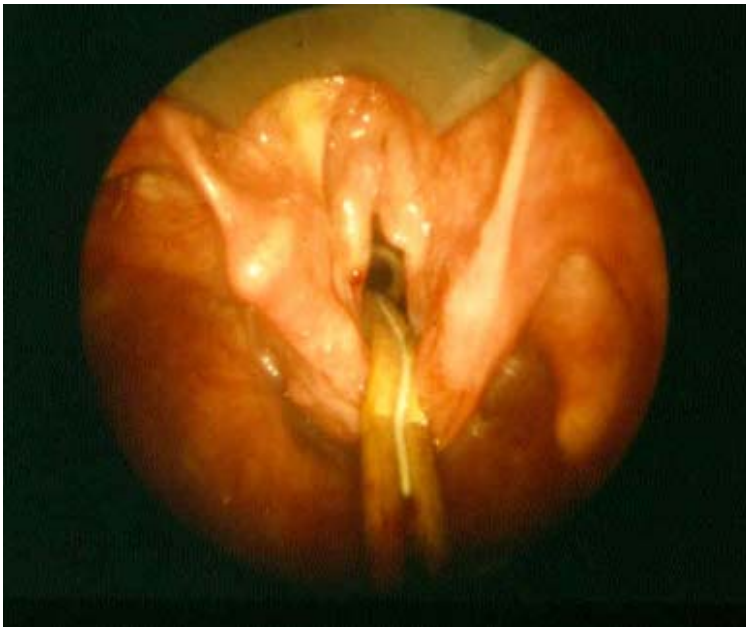

Figure 2

Laryngoscopic view of a double lumen copper pipe in situ.

Note the white welding line between the pipes and the upper of the two centralizing rings. The small curve leading over the glottis' threshold helps to place the pipe at the right depth.

OUR EXPERIENCES

Our department has used the copper tube since 1988 in several hundred patients until a decree on the use of self-adapted equipment in Finnish hospitals stopped its use. Indications for laser surgery are mostly benign tumours, papilloma being the most common but also other types of hyperplastic and granulomatous lesions. Also malignant neoplasms are suitable for laser surgery and the method is replacing irradiation in T₁ glottic lesions¹⁸⁻²⁰.

According to our experience endoscopists' working conditions are much better with jet ventilation compared to normal intubation, regardless how small the conventional intubation tube is. Furthermore the endolaryngeal working circumstances do not differ essentially between the plastic tubes and the non-flammable system.

SIDE – EFFECTS

The most frequent is a film of loose blood clottings inside the trachea in about half of the patients. This is however a completely innocent phenomenon from minor bleeding during the endolaryngeal procedure and needs no therapy. The next common is spot lacerations due to rubbing of the copper coil against tracheal mucosa but the areas of these lesions are small. Also some spot bleedings and diffuse reddening of the tracheal mucosa can occur, but according to our experience all these lesions of the tracheal wall were never circumferential like those caused by the cuff of an intubation tube and always smaller than the latter.

The most intense attention in the literature has been paid for ignition and combustion of ventilation materials. The Rüschi red rubber tube might be the least combustible. Several protecting techniques from wrapping the tube with aluminium or other metal foil stripes²¹ to application of dental acrylic compound to the outside of the tube have been tried²². Also the cuff has been filled with saline instead of air and even stained with methyl blue^{23 13}. Anyhow, in all these techniques there is a flammable material present very close to the area where the laser beam works forming so a potential risk for ignition and formation of toxic fumes²⁴. Although the ignition risk is rather low- 0.4 to 1.5% of the cases-²⁵ this untoward phenomenon can be totally avoided by using non-flammable tubes. Also the heating risk of the tube is very low because of the cool driving jet gas.

In conclusion, the non-flammable double lumen jet ventilation is very close to the ideal method in endolaryngeal surgery. In experienced hands the frequency of complications is very low and the nature of those only minor.

Reference List

1. Norton ML, Strong MS, Vaughan CW, Snow JC, Kripke BJ: Endotracheal intubation and venturi (jet) ventilation for laser microsurgery of the larynx. *Ann Otol* 1976; 85: 656-63
2. Janjevic D, Jovic R: [High Frequency Jet Ventilation and laryngeal surgery, clinical practice]. *Med Pregl*. 2008; 61 Suppl 2: 57-61
3. Oulton JL, Donald DM: A ventilating laryngoscope. *Anesthesiology* 1971; 35: 540-2
4. Barr NL, Itscoitz S, Chan.C., Economopoulos B, Albert SN: Oxygen injection in suspension laryngoscopy. *Arch Otolaryngol* 1971; 93: 606-9
5. Garden JM, O'Banian MK, Shelnitz LS, Pinski KS, Bakus AD, Reichmann ME, Sundberg JP: Paillomavirus in the vapor of carbon dioxide Laser-treated verrucae. *JAMA* 1988; 259: 1199-202
6. Spoerel WE, Greenway RE: Technique of ventilation during endolaryngeal surgery under general anaesthesia. *Can Anaesth Soc J* 1973; 20: 369-77
7. Carden E, Crutchfield W: Anaesthesia for microsurgery of the larynx (A new method). *Can Anaesth Soc J* 1973; 20: 378-89
8. Spoerel WE, Grant PA: Ventilation during bronchoscopy. *Can Anaesth Soc J* 1971; 18: 178-88

9. Smith RB, Schaer WB, Pfaeffle H: Percutaneous transtracheal ventilation for anaesthesia and resuscitation: a review and report of complications. *Can Anaesth Soc J* 1975; 22: 607-12
10. Cook TM, Alexander R: Major complications during anaesthesia for elective laryngeal surgery in the UK: a national survey of the use of high-pressure source ventilation. *Br J Anaesth* 2008; 101: 266-72
11. Hirshman CA, Smith J: Indirect ignition of the endotracheal tube during carbon dioxide laser surgery. *Arch Otolaryngol* 1980; 106: 639-41
12. Juri O, Frochoux D, Rajan GP, Biro P: [Ignition and burning of biological tissue under simulated CO₂-laser surgery conditions]. *Anaesthesist* 2006; 55: 541-6
13. Ossoff RH: Laser safety in otolaryngology - head and neck surgery: anesthetic and educational considerations for laryngeal surgery. *Laryngoscope* 1989; 99: 1-26
14. Baer GA, Paloheimo M, Rahnasto J, Pukander J: End-tidal oxygen concentration and pulse oximetry for monitoring oxygenation during intratracheal jet ventilation. *Journal of Clinical Monitoring* 1995; 11: 373-80
15. Pukander, J. and Baer, G. Non flammable copper jet ventilation tube in intralaryngeal laser surgery. Ribari, O. and Hirschberg, A. 363-367. 1996. Bologna, Monduzzi Editore S.p.A. EUFOS European Federation of Oto-Rhino-Laryngological societies. 6-9-1996.
16. Benjamin B, Gronow D: A new method for microlaryngeal surgery. *Anaesth Intensive Care* 1979; 7: 258-63
17. Davies JM, Hillel AD, Maronian NC, Posner KL: The Hunsaker Mon-Jet tube with jet ventilation is effective for microlaryngeal surgery. *Can J Anaesth* 2009; 56: 284-90
18. Pukander J, Kerala J, Makitie A, Hyrynkangas K, Virtaniemi J, Grenman R: Endoscopic laser surgery for laryngeal cancer. *Eur. Arch Otorhinolaryngol.* 2001; 258: 236-9
19. Kujath M, Kerr P, Myers C, Bammeke F, Lambert P, Cooke A, Sutherland D: Functional outcomes and laryngectomy-free survival after transoral CO laser microsurgery for stage 1 and 2 glottic carcinoma. *J Otolaryngol. Head Neck Surg* 2011; 40 Suppl 1: S49-S58
20. Suarez C, Rodrigo JP, Silver CE, Hartl DM, Takes RP, Rinaldo A, Strojjan P, Ferlito A: Laser surgery for early to moderately advanced glottic, supraglottic, and hypopharyngeal cancers. *Head Neck* 2011;
21. Strong MS, Jako GJ, Polanyi T, Wallace RA: Laser surgery in the aerodigestive tract. *Am J Surg* 1973; 126: 529-33
22. Kumar A, Frost E: Prevention of fire hazard during laser microsurgery. *Anesthesiology* 1981; 54: 350
23. LeJeune FE, Jr., Guice C, LeTard F, Marice H: Heat sink protection against laser endotracheal cuffs. *Ann. Otol. Rhinol. Laryngol.* 1982; 91: 606-7
24. Pratt LW: The CO₂ laser in otolaryngology. *J Maine. Med Assoc.* 1980; 71: 39-40, 45
25. Hermens JM, Bennett MJ, Hirshman CA: Anesthesia for laser surgery. *Anesth Analg* 1983; 62: 218-29

JV FOR DIFFICULT INTUBATIONS AND EMERGENCIES

Dusanka Janjevic, MD
Clinical Centre of Vojvodina
University Hospital
ENT Clinic, Department of Anaesthesia
Novi Sad
Serbia

Introduction

The primary goal in airway management is to safely provide oxygenation and ventilation. The consequences of lack of oxygenation due to difficulties or failure with facemask, supraglottic device, tracheal tube or transtracheal device can be catastrophic. Though an infrequent occurrence, failed tracheal intubation is the primary cause in anaesthesia of hypoxia, brain damage, and death.

Under these circumstances transtracheal access at the level of the cricothyroid ligament provides immediate oxygenation and ventilation. In the “can’t intubate, can’t ventilate” (CICV) scenario cricothyroidotomy is recommended if all other methods of ventilation have failed, in order to rapidly restore oxygenation.

Needle cricothyroidotomy with percutaneous translaryngeal ventilation can be a life-saving procedure when an emergency airway is needed. Appropriate ventilatory parameters using a high-flow oxygen source and an adequate expiratory time may limit the complications of barotrauma and allow for a more extended time of ventilation. The emergency physician should be familiar with the indications, contraindications and complications. Transtracheal jet ventilation (TTJV) must be viewed as procedure providing adequate gas-exchange and ensuring the patency of the airway until a definitive procedure such as oral intubation or surgical tracheotomy can be performed.

The objective of this presentation is to show the benefit of TTJV via a needle cricothyroidotomy as a temporary life saving procedure in cases of difficult or failed endotracheal intubation in adults and children and the use of this technique prophylactically for the management of anticipated/known difficult airway in ENT surgery^(1,2,3,4,5).

Transtracheal jet ventilation via a needle cricothyroidotomy

Resuscitation employing TTJV during difficult intubation is not a new concept for the anaesthetist, otolaryngologist and emergency room physicians. In an elective or emergency setting, transtracheal jet ventilation via a needle cricothyroidotomy may be life saving^(5,6).

Oxygenation via transtracheal cannula was first described in the early fifties by Jacoby^(6,7) who was able to avoid hypoxemia in anaesthetized patients with complete respiratory obstruction by using an oxygen flow of 4 L min⁻¹ via an 18 G cricothyroid

cannula. Later, Spoerel *et al* ⁽⁸⁾ introduced transtracheal jet ventilation with high-pressure oxygen via a 16 G needle. Ravussin and Freedmen first described the 13 G VMB cannula used to ventilate their patients with HFJV, who required surgical procedures in the upper airway or presented a difficult airway ⁽⁹⁾. Preliminary reports suggest that needle cricothyroidotomy with TTJV may be useful for endotracheal intubation of patients who have a difficult or failed airway and may help prevent aspiration, although further studies are needed. TTJV is included in most algorithms of difficult oxygenation and difficult intubation ⁽¹⁰⁾. The Difficult Airway Society (DAS) protocol and other current airway guidelines for the CICV scenario recommend the use of a kink-resistant cannula for crico-thyroidotomy with jet ventilation. Results of several studies suggest to use the benefits of TTJV in adult patients with stridor and critical airway obstruction ^(1,2,11). A recently published study in animals described the possibility to confirm the correct placement of the cricothyroidotomy needle with a special esophageal detector device ⁽¹²⁾. Further investigation is needed to identify a standardized apparatus for needle cricothyroidotomy in emergency situations. On the other hand most publications stress that successful use of needle cricothyroidotomy requires training and familiarity of the physicians with this meticulous technique to prevent complications. There is a high incidence of complications when the technique is used by inexperienced personnel ^(13,14,15).

Transtracheal jet ventilation system. The TTJV system consists of a high-pressure oxygenation source (usually central wall oxygen pressure of 50 psi, 344.7kPa), high-pressure oxygen tubing, a regulator to control the driving pressure, an on-off valve to control inspiratory time, high-pressure tubing, and a Luer lock to connect to the cannula. Oxygen can be delivered via a jet ventilation device such as Manujet; VMB Medical, Germany, which enables control of delivery pressure as well as flow Bouldi ⁽¹⁶⁾.

The kink-resistant cannula (Ravussin, VMB which is available in size of 13-16G and the Benumof needle of 2 mm, Cook) designed for TTJV is preferable to standard intravenous cannulas because of the tendency of the latter to kink. Effective ventilation through a cannula is only possible when a high-pressure source is used. Verification of correct cannula placement by aspiration of air into a large syringe before the use of high-pressure ventilation is essential. Subsequent displacement of the cannula must be prevented. During transtracheal (puncture) jet ventilation (JV) it is essential that the expiratory pathway is unobstructed. The occlusion of the expiratory pathway rapidly leads to hypoventilation, manifested by hypercarbia and hypoxaemia, and interferes with cardiac output by increasing the intrathoracic pressure, with the risk of producing serious barotrauma to the lung. It is therefore important to understand the principles (the mechanism and basic physical properties) of JV in order to understand how it may help in the CICV situation ^(14,15,17).

TTJ and CICV scenario. The Difficult Airway Society (DAS) protocol and the other current airway guidelines for the CICV scenario recommend the use of kink-resistant

cannula cricothyroidotomy with transtracheal jet ventilation or surgical cricothyroidotomy.

The “can’t intubate, can’t ventilate (CICV) situation may be defined as the situation in which ventilation with non-invasive techniques fails to maintain oxygenation and tracheal intubation proves impossible. Rapid development of severe hypoxaemia, particularly associated with bradycardia, is an indication for imminent intervention with an invasive technique. The risk of an invasive rescue technique must be constantly weighed against the risk of hypoxic brain damage or death. The CICV scenario is fortunately rare but for all anaesthetists a feared emergency situation. Although TTJV is rarely performed in the emergency settings, it is a simple, relatively effective means of supporting oxygenation. The advantages of this technique over cricothyroidotomy may include speed, a simple use, and less bleeding. It can also provide an alternative for physicians unable to perform cricothyroidotomy. Patients’ age is not a restriction to TTJV, which is the surgical airway of choice for children younger than 12 years. Needle cricothyroidotomy with TTJV is a surgical airway that may be used to temporize in the CICO situation, particularly in children. There are several other aspects of this technique that differ from cricothyroidotomy important to consider. To provide ventilation, supraglottic patency must be maintained to allow for expiration. In the case of complete upper airway obstruction, air stacking from TTJV will cause barotrauma; therefore, cricothyroidotomy is preferable. Another significant difference is that the cannula in TTJV does not provide airway protection. Also, suctioning cannot adequately be performed through the percutaneous catheter. TTJV is therefore best considered a temporizing means of rescue oxygenation until a more definitive airway can be obtained.

The complications associated with transtracheal jet ventilation include: damage to the tracheal cartilages, barotrauma, reflex cough with each ventilation, catheter kinking, obstruction from blood and mucus, esophageal puncture, and mucosal damage if nonhumidified gas is used. The false passage of the catheter can lead to pneumomediastinum and surgical emphysema if jet ventilation is attempted. Pneumothorax can occur if jet ventilation is attempted after correct placement of the catheter when there is a significant airway obstruction^(1,2,9,11,18).

Emergency jet ventilation in children. An unanticipated difficult airway is very uncommon in infants. Major difficulties in managing the pediatric airway arise relatively infrequently and are usually predictable. The “can’t intubate, can’t ventilate” scenario is very rare in pediatrics. The recommendations for managing the CVCi situation in infants and small children are based on difficult airway algorithms for adults. The Advanced Life Support Group (ALSG) and the American Society of Anesthesiologists (ASA) recommend that for emergency airway management in children, needle cricothyroidotomy should be used in place of an open surgical technique. Needle cricothyroidotomy is preferred over surgical cricothyroidotomy in infants and young children. ALSG recommends using 14-gauge cannula for children and 18-gauge for babies. The diameter of these cannulas is not sufficient to allow

conventional ventilation and in these circumstances a jet ventilation technique is needed. Inserting a cricothyroid needle in children is technically difficult because the anatomical structures are smaller and more easily compressed^(17,18).

Only those familiar with jet ventilation should consider its use. If ventilation is used, the ventilator requires an adjustable pressure regulator. Start with low pressure (20 psi) and titrate to adequate chest rise and fall and oxygen saturation, using exceedingly brief bursts of ventilation while observing chest rise, followed by sufficient exhalation time again judged by watching the chest fall. There is little published evidence to support TTJV as an emergency method of ventilation in children and the evidence from adults is not encouraging, considering that technical difficulties with the jet will increase in the smaller, more compressible airway.

In a recent study Bolton considered that pressure- and flow-limited jet ventilators such as a Manujet system could be used with a degree of safety to allow ventilation in a CICV situation in children where a trans-tracheal catheter may be lifesaving^(18,19,20).

Prophylactic placement of cricothyroidotomy cannula

Jet ventilation via transtracheal catheter is now an established procedure for ENT surgery. The use of transtracheal (transdermal) JV prophylactically for the management of an anticipated/known difficult airway is getting more popular in recent time.

The procedure involves inserting a dedicated narrow bore cannula (e.g. Ravussin) through the cricothyroid membrane under local anaesthesia before performing the definitive technique. The transtracheal cannula can be used to maintain oxygenation if the intubation procedure runs into problem, especially in complex ENT surgery. Recent studies suggest that percutaneous transtracheal jet ventilation is a safe and effective technique, which can help to avoid tracheotomy. It should be available for patients with head and neck cancer, undergoing general anaesthesia, when a difficult airway is anticipated. The procedure requires experience and may be difficult to perform in patients with a rapid deteriorating upper airway. Fiber optic intubation has been the preferred technique in most patients with compromised upper airway due to pathology above the glottis, at or near glottis. With fiber optic intubation there is a chance to develop total obstruction either when spraying local anaesthetic or by stimulation with the fiberscope itself. Also there is a possibility to cause bleeding. Under these circumstances, transtracheal catheter and JV provides immediate oxygenation and ventilation until definitive airway management or surgical tracheotomy is performed. With transtracheal JV it is vital to keep the upper airway as open as possible with jaw-thrust and to verify deflation of the lungs and exhalation through the upper airway. If the system is closed barotrauma becomes a real and serious risk.

Another opportunity to practice TTJV was reported by Ross-Anderson *et al.* They described the use of TTHFJV in 50 patients with severe airway compromise and stridor undergoing pharyngolaryngeal surgery with no major complications^(11,21,22). In patients with bilateral vocal cord palsy (serious complication after thyroid surgery), suffering

from dyspnea, stridor and critical airway obstruction, the other choice would be a surgical tracheotomy. In these patients, TTHFJV has been an established technique, which allows adequate oxygenation, continuous airway patency, good exposure of the larynx and immobility of vocal cords^(23,24).

Conclusion

JV is the method of choice for oxygenation and ventilation if transtracheal access to the airway through a narrow cannula is considered to be the next step, an appropriate step in an algorithm to manage a difficult airway situation. TTJV is a temporary means to gain time until a definitive method of securing the airway can be performed. Every anaesthetist should be familiar with transtracheal ventilation since they may face a CICO situation. During transtracheal jet ventilation it is essential that the expiratory pathway is unobstructed. The regular use of this technique requires: clinical training of skill, profound knowledge of basic physical properties of JV and clinical experience. Jet ventilation should be used more frequently in routine practice both in elective and emergency settings.

References

1. American Society of Anaesthetic Task Force on Management of the Difficult Airway. Practice guidelines for Management of Difficult Airway. An updated report. *Anaesthesiology* 2003;95:1269-1277.
2. Henderson JJ., Popat MT., Latta IP., Pearce AC. Difficult Airway Society guidelines for management of the unanticipated difficult intubation. *Anaesthesia* 2004;59:675-694.
3. Crosby ET., Cooper RM., Dwyer MJ et al. The unanticipated difficult airway with recommendations for management. *Can J Anaesth* 1998;45:757-776.
4. Popat M., Dudnikov S. Management of the obstructed upper airway. In *Current Anaesthesia and Critical Care. Focus on Difficult Airway*, ed Pollard BJ. Harcourt Publisher Ltd, London 2001;12:225-30.
5. Patel R. Use of percutaneous Transtracheal Jet Ventilation (TTJV) during Difficult Airway Management. *The Internet Journal of Emergency and Intensive Care Medicine* 1999;Vol 3 N1:<http://www.ispub.com/journals/IJEICM/Vol3N1/ptjv.htm>.
6. Patel R. Percutaneous transtracheal jet ventilation: a safe, quick and temporary way to provide oxygenation and ventilation when conventional methods are unsuccessful. *Chest* 1999;116:1689-1694.
7. Jacoby JJ., Hamelberg W., Ziegler CH, et al. Transtracheal resuscitation. *JAMA* 1956;162:625-628.
8. Spoerel WE., Narayanan PS., Singh NP. Transtracheal ventilation. *Br J Anaesth* 1971;43:932-939.
9. Ravussin P., Freeman J. A new transtracheal catheter for ventilation and resuscitation. *Can Anaesth Soc J* 1985;32:60-64.
10. Mace SE., Khan N. Needle cricothyroidotomy. *Emerg. Med Clin. Nort Am* 2008;26(4):1085-1101.

11. Ross-Anderson DJ., Ferguson., Patel A. Transtracheal jet ventilation in 50 patients with severe airway compromise and stridor. *Br J Anaesth* 2011;106 (1):140-144.
12. Schuh JR., Bettendorf R., Shapiro D. et al. Confirmation of needle cricothyroidotomy using an esophageal detector devices in a porcine model. *Mil Med* 2010;275(9):686-687.
13. Bourgain JL., Chollet M., Fischler M. et al. Guide for the use of jet ventilation during ENT and oral surgery. *Ann Fr Anaesth Reanim.* 2010;29(10):720-727.
14. Green L. Can't intubate, can't ventilate. A survey of knowledge and skills in a large teaching hospital. *European J of Anaesth* 2009;26:480-483.
15. Mong TD., Prabhu AJ et al. What is minimum Training Required for Successful Cricothyroidotomy? *Anesthesiology* 2003;V98:No2,349-353.
16. Bouldi M., Bearfield P. Techniques for emergency ventilation through a needle cricothyroidotomy. *Anaesthesia* 2008;63:535-539.
17. Ravussin P., Bayer-Berger M., Monnier P. Percutaneous transtracheal ventilation for endoscopic procedures in infants and small children with laryngeal obstruction: report of cases. *Can J Anaesth* 1987;34:83-86.
18. Bolton F. Emergency jet ventilation in children. *Pediatric Anaesthesia* 2009;19:425-427.
19. Hamaekers A., Borg P., Enk D. The importance of flow and pressure release in emergency ventilation devices. *Pediatr Anaesth* 2009;19:425-457.
20. Mackway-Jones K., Molyneux E. *Advanced Paediatric Life Support the Practical Approach*, 3rd and BMJ, London:Tavistock Square, 2001.
21. Gulleth Y. TTJV as an option in airway management in head and neck surgery. *Arch Otolaryngol Head Neck Surg.* 2005;131(10):886-90
22. Chandradeva K., Palin C., Ghosh SM. Percutaneous transtracheal jet ventilation as a guide in severe upper airway obstruction from supraglottic oedema. *Br J Anaesth* 2005;94:683-686.
23. Cook TM., Alexander R. Major complications during anaesthesia for elective laryngeal surgery in the UK: a national survey of the use of high-pressure source ventilation. *Br J Anaesth* 2008;101:266-272.
24. Willams A., Patel A., Ferguson C. High frequency jet ventilation through the laryngeal mask airway in a critically obstructed airway. Case Report. *Anaesthesia* 2008;63:1369-1371.

Jet ventilation in the presence of airway stenosis: advantages, drawbacks, and complications

Gerald C. Ihra, MD

Department of Anaesthesiology and Intensive Care Medicine, Medical University of Vienna
A 1090 Vienna, Austria

www.ihra.at, gerald.ihra@meduniwien.ac.at

Jet ventilation is an alternative ventilatory technique with specific advantages when used for diagnostic or surgical interventions in patients with airway pathology.¹ Tidal volumes delivered via small-bore catheters or cannulae will guarantee adequate oxygenation when access to the airway is restricted or when laryngotracheal stenosis severely reduces gas flow. However, damage resulting from the application of high-pressurized gas has also to be considered.²

Advantages, drawbacks and potential complications associated with the use of jet ventilation in patients with airway stenosis will be discussed in this article.

ADVANTAGES OF JET VENTILATION: Main advantages offered by jet ventilation in anesthetized patients include the positioning of jet catheters with less effort than large tubes in the presence of airway stenosis, an improvement of surgical access and viewing of the larynx, the performance of laser surgery with less risk by avoiding the use of flammable plastic materials, a reduced risk of aspiration of blood and debris due to a continuous outflow of gases when high-frequency jet pulses are used, the continuous ventilation during tracheal surgery when jet streams are applied distally, and ventilation of the patient's lung following puncture of the cricothyroid membrane as an effective rescue measure.¹

With regard to the position of the injector's outlet to the glottic opening, the method can be performed as supraglottic or infraglottic jet ventilation. Supraglottic techniques offer the advantage not to obstruct the surgical field which will be completely free of any ventilating instruments. The supraglottic technique has also been reported to result in a decreased risk of complications.³ The infraglottic technique can be instituted non-invasively by insertion of a translaryngeal jet catheter, or more invasively after puncture of the cricothyroid membrane or the anterior tracheal wall. Thereby, transtracheal jet ventilation has been considered not only for elective surgery⁴ but also as a means to manage "cannot intubate, cannot ventilate" emergencies and is listed as a potential option in the ASA difficult airway algorithm.⁵

AIRWAY STENOSIS: Airway stenosis may arise from a variety of causes like trauma, infection, tumor, aspirated foreign bodies, tracheal constriction after intubation, or may accompany congenital defects in infants. Considering a normal tracheal diameter between 7 and 8 mm in small children, and 18 and 22 mm in adults,⁶ reductions in airway cross sectional area may result from extrinsic compression, mural lesions, or intraluminal objects. In addition to such structural types of stenosis, there can also be functional types resulting from malacic conditions or a floppy posterior tracheal membrane. Various classification systems to describe location and degree of stenosis have been proposed.^{7,8} Because of the narrowness of children's airways, high grade stenosis caused by dynamic processes like swelling will develop earlier and faster in small children than in adults. Typical

clinical symptoms of severe airway compromise include stridor, dyspnea, cyanosis, hoarseness or aphonia, and feeding disorders in small children.

By affecting intraluminal gas flow and applied gas volumes, stenosis will either decrease or increase lung pressures. End-expiratory pressure and peak lung pressure may sometimes be affected in different ways, e.g. a rise in PEEP may be accompanied by a reduction in peak pressures.⁹ (Figure 1) In general, the effect of a stenosis on pressures in the airways and in the lung during jet application will depend on the degree of obstruction, injector's diameter and position, the driving pressure set on the ventilator, and the time constant of the lung/thorax system. Driving pressure and injector's diameter determine delivered jet gas volume according to the principle of Hagen-Poiseuille coupling the flow of gases to the diameter of pipes and the pressure applied. High airway pressures have to be expected when large volumes of gas will enter the lungs and/or when expiratory gas flow is severely reduced. Depending on the injector's position with regard to airway stenosis, suprastenotic and infrastenotic jet ventilation types have to be distinguished.

LUNG PRESSURES: High lung pressures may originate from several factors and appear to be associated with jet application, surgical manipulation and the anatomical nature of the restricted airway. If jet ventilation is delivered at high respiratory rate intrinsic positive end-expiratory pressure (PEEP_i) may develop due to reduction of the expiratory phase of the respiratory cycle and an incomplete emptying of the lung. During jet ventilation, levels of PEEP_i depend on driving pressure and jet frequency.¹⁰ This phenomenon of air trapping is also well known for mechanical ventilation, when respiratory rates are high, or when expiratory gas flow is limited by a decrease in airway diameter. Obviously the simultaneous occurrence of both conditions even more predisposes patients to the development of inadvertent PEEP_i. In vitro data have demonstrated this effect during jet ventilation.^{9,11} Thus, special care must be taken to ensure an adequate exhaust of delivered gas volume.

Secondly, expiratory airflow reduction may result from obstruction of the airway by surgical instruments, and high peak lung pressures may develop within seconds, when jet gas is continually applied. Because jet streams are delivered actively with high pressure, but expiration is driven passively by the elastic forces of the expanded lung and thorax, instreaming gas will be less affected than the outflow of gas and consequently lung volumes and pressures will increase. This risk increases in patients with high-degree stenosis. Therefore, technical mechanisms for flow and pressure release in jet devices are requested from manufacturers. However, measurement of airway pressure in vivo is difficult in open ventilation systems, and dangerously enhanced lung pressures may eventually not be detected. Thus, airway pressures have been studied in various experimental models. Fixed orifice restrictors to simulate central airway stenosis as well as models investigating dynamic obstruction have been used to demonstrate the effect of stenosis on pressures.^{12,13,14}

There has been some debate whether suprastenotic jet application may result in higher airway pressures than infrastenotic jet ventilation. Some investigators found higher distal airway pressures and increased tidal volumes when jets were applied above stenosis.¹³ They suspected that air entainment is causative for this effect, because more air will be entrained around jet streams above stenoses than when jets are delivered below stenoses. However, it has been clarified recently that this effect depends crucially on the injector's position in relation to the restricted airway.¹⁴ When jet injectors are in close proximity (e.g. 1 cm) to the restriction, increasing degrees of stenosis will result in increasing lung pressures. Placement of an injector's nozzle more proximal to the restriction (> 3 cm) will lead to a decrease in lung pressure, and pressures will further decrease when airway diameters are reduced. Therefore, distant injectors like the types used in special ventilating laryngoscopes³ may prevent development of harmful intrapulmonary pressure during high-frequency jet ventilation.

COMPLICATIONS: Complications associated with supraglottic or infraglottic jet ventilation may include gastric distension resulting from misdirected or dislodged injectors, cardiac dysrhythmias, a blood pressure drop when venous return is diminished due to enhanced intrathoracic pressure, subcutaneous emphysema, pneumothorax, pneumomediastinum, pneumopericardium and even death has been observed.^{2,15,16}

Combined techniques of jet ventilation have also been introduced into clinical practice.¹⁷ Gas exchange may be improved when two jet streams are applied simultaneously.¹⁸ Adequate gas exchange and the absence of complications were reported when two injectors integrated in special jet laryngoscopes were utilized.³ However, the superimposed technique makes use of an additional high-frequency jet stream to deliberately generate an intrinsic PEEP and therefore should be used with caution in situations which induce PEEP_i by other mechanisms.

CONCLUSION: Jet ventilation can be a valuable and highly effective tool to optimize conditions during airway surgery. However, a national survey focused on the use of high-pressure source ventilation and reported severe complications. The authors described serious morbidity and more complications when the technique was utilized less frequently than in medical centers with more clinical experience.² Therefore, adherence to guidelines, regular training and clinical experience is a prerequisite in order to apply jet streams safely and to reduce the risk of severe complications. Because patients with severe airway compromise confront specialists with an increased risk of adverse outcome, only well trained personal should consider a complex technique like jet ventilation as an appropriate approach to secure the airway and to maintain oxygenation during airway surgery.

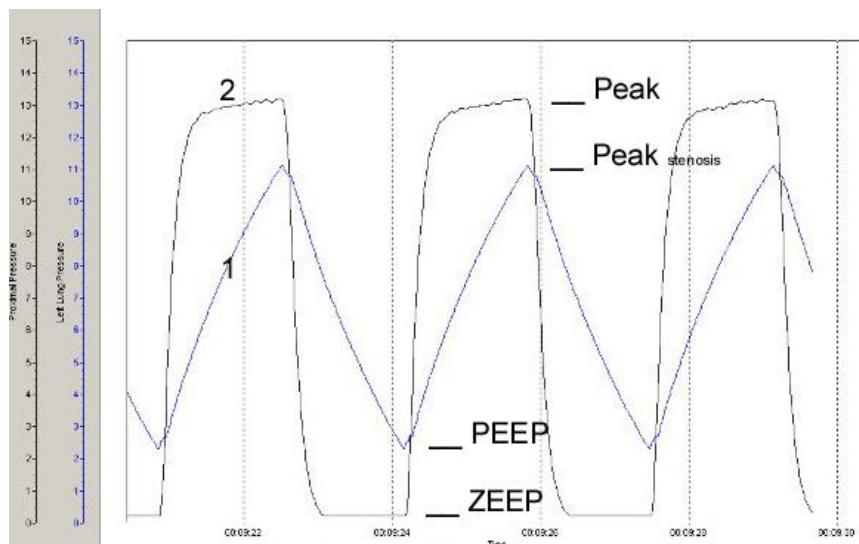

Figure 1. Effect on lung pressures during suprastenotic jet ventilation (in vitro test lung system): Blue graph (1) shows a decrease in peak lung pressure (Peak_{stenosis}) but development of intrinsic PEEP in the presence of a tracheal stenosis. Black graph (2) illustrates same system without airway obstruction (Peak, ZEEP = zero PEEP)

1. Ihra G, Gockner G, Kashanipour A, Aloy A: High-frequency jet ventilation in European and North American institutions: developments and clinical practice. *Eur J Anaesth* 2000; 17: 418-30
2. Cook TM, Alexander R: Major complications during anaesthesia for elective laryngeal surgery in the UK: A national survey of the use of high-pressure source ventilation. *Brit J Anaesth* 2008; 101:266-72
3. Rezaie-Majd A, Bigenzahn W, Denk DM, Burian M, Kornfehl J, Grasl MC, Ihra G, Aloy A: Superimposed high-frequency jet ventilation (SHFJV) for endoscopic laryngotracheal surgery in more than 1500 patients. *Brit J Anaesth* 2006; 96:650-59
4. Depierraz B, Ravussin P, Brossard E, Monnier P: Percutaneous transtracheal jet ventilation for paediatric endoscopic laser treatment of laryngeal and subglottic lesions. *Can J Anaesth* 1994; 41: 1200-07
5. American Society of Anesthesiologists Task Force on Management of the Difficult Airway. Practice guidelines for management of the difficult airway: an updated report by the American Society of Anesthesiologists Task Force on Management of the Difficult Airway. *Anesthesiology* 2003; 98: 1269-77
6. Beneke G, Endres O, Becker H, Nitschke H: Wachstum und altersabhängige Strukturveränderungen der menschlichen Trachea. *Virchows Arch Pathol Anat Physiol Klin Med* 1966; 341: 353-64
7. Cotton RT: Pediatric laryngotracheal stenosis. *J Ped Surg* 1984; 19: 699-704
8. Freitag L, Ernst A, Unger M, Kovitz K, Marquette CH: A proposed classification system of central airway stenosis. *Eur Respir J* 2007; 30:7-12
9. Ihra G, Tsai C, Kimberger O: Intrinsic PEEP at various frequencies of supraglottic jet ventilation in a model of dynamic upper airway obstruction. *Anesth Analg* 2010; 111:703-6
10. Spackman DR, Kellow N, White SA, Seed PT, Feneck RO. High frequency jet ventilation and gas trapping. *Brit J Anaesth* 1999; 83:708-14
11. Ihra G. High-frequency jet ventilation in the presence of airway stenosis leads to inadvertent high PEEP levels. *Ped Anesth* 2008; 18, 905-6
12. Ng A, Russell WC, Harvey N, Thompson JP: Comparing methods of administering high-frequency jet ventilation in a model of laryngotracheal stenosis. *Anesth Analg* 2002; 95: 764-69
13. Buczkowski PW, Fombon FN, Lin ES, Russell WC, Thompson JP. Air entrainment during high frequency jet ventilation in a model of upper tracheal stenosis. *Br J Anaesth* 2007; 99: 891-97
14. Ihra GC, Heid A, Pernerstorfer T: Airway stenosis related elevation of pulmonary pressure during high-frequency jet ventilation depends on injector's position. *Anesth Analg* 2009; 109: 461-65
15. Jaquet Y, Monnier P, Van Melle G, Ravussin P, Spahn DR, Chollet-Rivier M: Complications of different ventilation strategies in endoscopic laryngeal surgery. *Anesthesiology* 2006; 104:52-59
16. Mikkelsen S, Knudsen KE: Pneumopericardium associated with high-frequency jet ventilation during laser surgery of the hypopharynx in a child. *Eur J Anaesth* 1997; 14: 659-61
17. Ihra G, Hieber C, Schabernig C, Kraincuk P, Adel S, Plöchl W, Aloy A: Supralaryngeal tubeless combined high-frequency jet ventilation for laser surgery of the larynx and the trachea. *Brit J Anaesth* 1999; 83:940-42
18. Bacher A, Lang T, Weber J, Aloy A: Respiratory efficacy of subglottic low-frequency, subglottic combined-frequency, and supraglottic combined-frequency jet ventilation during microlaryngeal surgery. *Anesth Analg* 2000; 91:1506-12